VCO Fundamentals

John McNeill

Worcester Polytechnic Institute

`mcneill@ece.wpi.edu`

A curved, light-blue path that starts at the top left and curves downwards to the right. Along this path, various electronic components are arranged, including a large metal enclosure, a printed circuit board (PCB) with numerous components, a small metal component, a larger metal component with a connector, and a series of small, identical components at the bottom right.

RF/IF & Microwave Products

DC-40 GHz

Mini-Circuits Company Overview

- **Founded: 1969**
- **Headquarters: Brooklyn, NY**
- **Multiple Design Centers**
 - Brooklyn
 - San Jose
 - Israel
 - Malaysia
 - India
- **Multiple Core Technologies**
 - Core & Wire
 - Microstrip
 - LTCC
 - Semiconductors
- **Over 10,000 active products**
- **Over 20,000 active customers**



Mini-Circuits

Excellence in Performance

Proven strategies for producing the world's best RF MMIC's



ISO 9001:2000
our promise to our customers

- meet stated requirements
- exceed expectations
- continuously be improved

Mini-Circuits

ISO 14001:2002
our commitment to the environment

- regulatory compliance
- pollution prevention
- continual improvement

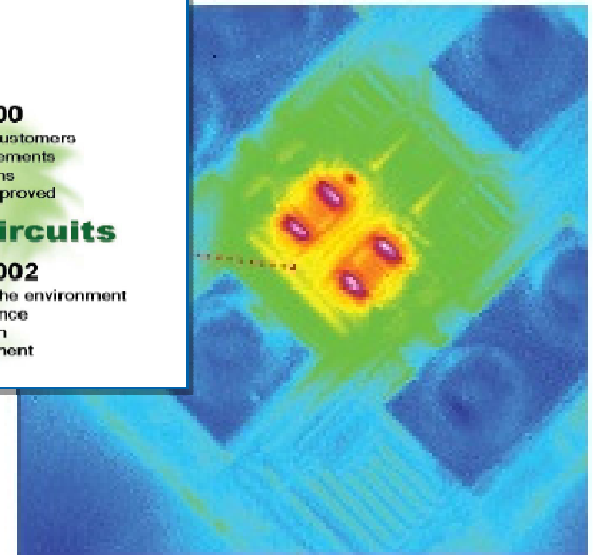

Mini-Circuits: a Passion for VALUE

Products that make a contribution:

- Outstanding Electrical Performance
- Reduced Size
- Leading Price
- Quick Delivery

Mini-Circuits Quality Policy

To provide products and services to our internal and external customers that:

- Meet stated requirements
- Exceed expectations
- Continuously improve



28 Product Lines from DC to 40 GHz

- Adapters
- Amplifiers
- Attenuators
- Bias Tees
- Cables
- Couplers
- Custom Assemblies
- DC Blocks
- Designer Kits
- Electronic Line Stretchers
- Filters
- Frequency Mixers
- Frequency Multipliers
- Impedance Matching Pads
- Limiters
- Modulators / Demodulators
- Phase Detectors
- Phase Shifters
- Portable Test Equipment
- Power Detectors
- Power Splitters / Combiners
- RF Chokes
- Switches
- Synthesizers
- Terminations
- Transformers RF/IF
- **Voltage Controlled Oscillators**
- Voltage Variable Equalizers

The World's Largest Selection of VCOs

- Over 800 catalog models, 12 MHz to 6.8 GHz
 - Hundreds more ready for fast turnaround
 - All available for rapid customization, 3 MHz to 7.1 GHz
- Frequency range from 1 MHz to >1 octave
- Various models optimized for linear tuning, dual output, low phase noise, 5V PLL/synthesizer, etc
- Tuning sensitivity from 1 to 180 MHz/V
- Phase noise as low as -135 dBc/Hz @ 10 kHz offset
- P_{OUT} up to +15 dBm
- SMD cases as small as 0.2 x 0.2 x 0.1"

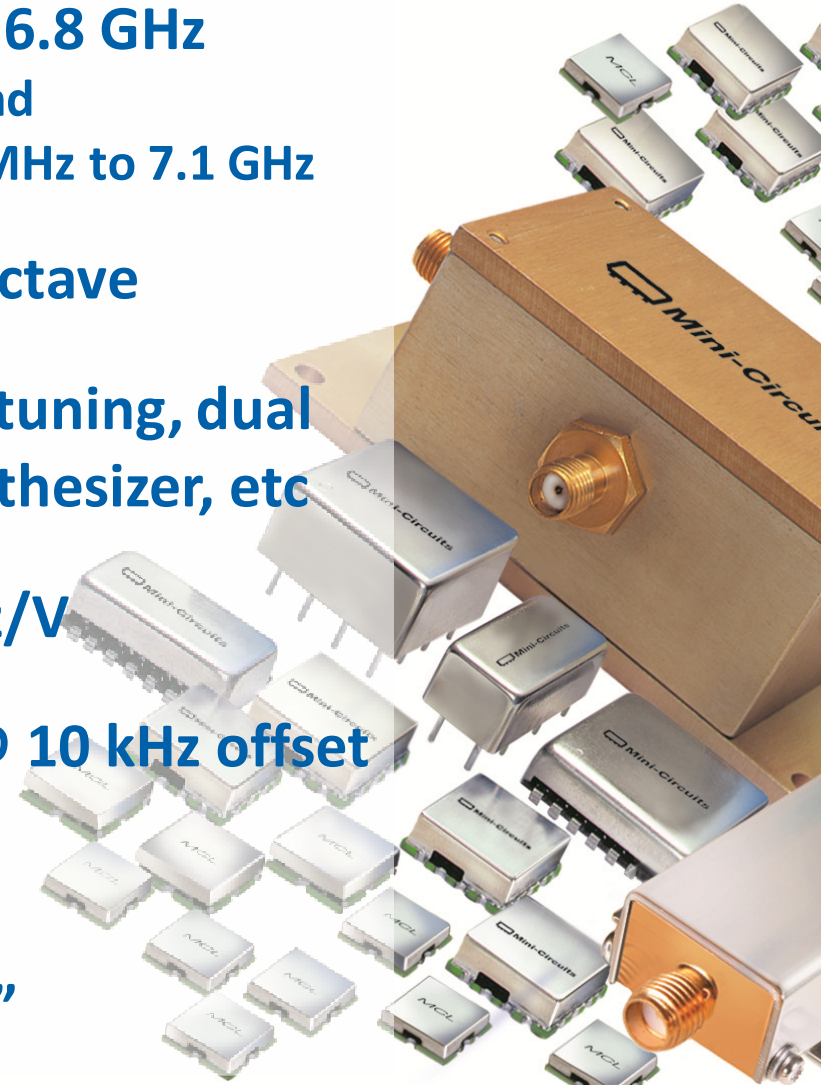

A Better Way to Find What You Need



Search millions of live test data points from thousands of products, to meet or exceed your performance requirements:

- Current catalog models
- Previous custom models
- Development models

Just enter a few specifications...

Package Style Plug-In Surface Mount Connector

Frequency (MHz) Low High

Supply Voltage (V) Low High

Phase Noise (SSB dBc/Hz @ offset) 1 kHz 10 kHz 100 kHz 1 MHz

Max.

Harmonic Suppression (dBc) 2nd 3rd 4th

Max.

Power Output (dBm) Min.

Tuning Sensitivity (MHz/V) Min. Max

Tuning Voltage (V)

(min)

Product lines included:

- Amplifiers
- Frequency Mixers
- Directional Couplers
- Power Splitter/Combiners
- RF Transformers
- Filters
- VCOs
- Synthesizers
- More to come

Model Name	Frequency [MHz]		Tuning Voltage [V]		Power Supply		Case Style	Price [\$]
	Low	High	Min.	Max.	Voltage [V]	Current [mA] Max.		
ROS-1700W+	770	1700	1	24	12	35	CK605	...

...and see all the models that match,
(as well as any close calls) in a snap!

VCO Fundamentals

John McNeill

Worcester Polytechnic Institute

`mcneill@ece.wpi.edu`



Overview

- **Functional Block Concept**
- **Oscillator Review**
- **Basic Performance Metrics**
- **Methods of Tuning**
- **Advanced Performance Metrics**
- **Conclusion**

Overview

- **Functional Block Concept**
 - **Applications**
 - **Specifications**
- **Oscillator Review**
- **Basic Performance Metrics**
- **Methods of Tuning**
- **Advanced Performance Metrics**
- **Conclusion**

Functional Block Concept

- Input control voltage V_{TUNE} determines frequency of output waveform

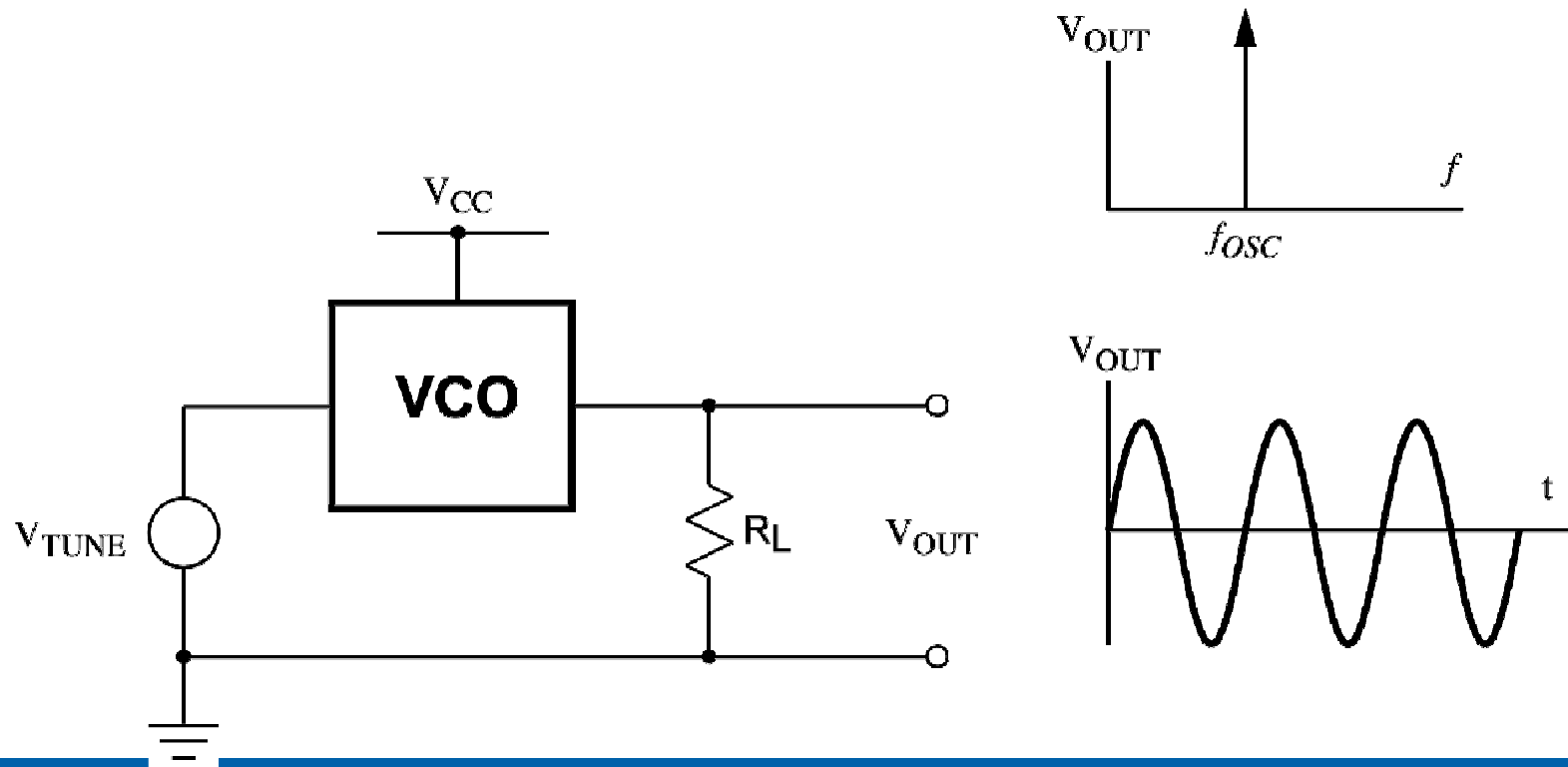

Applications: RF System

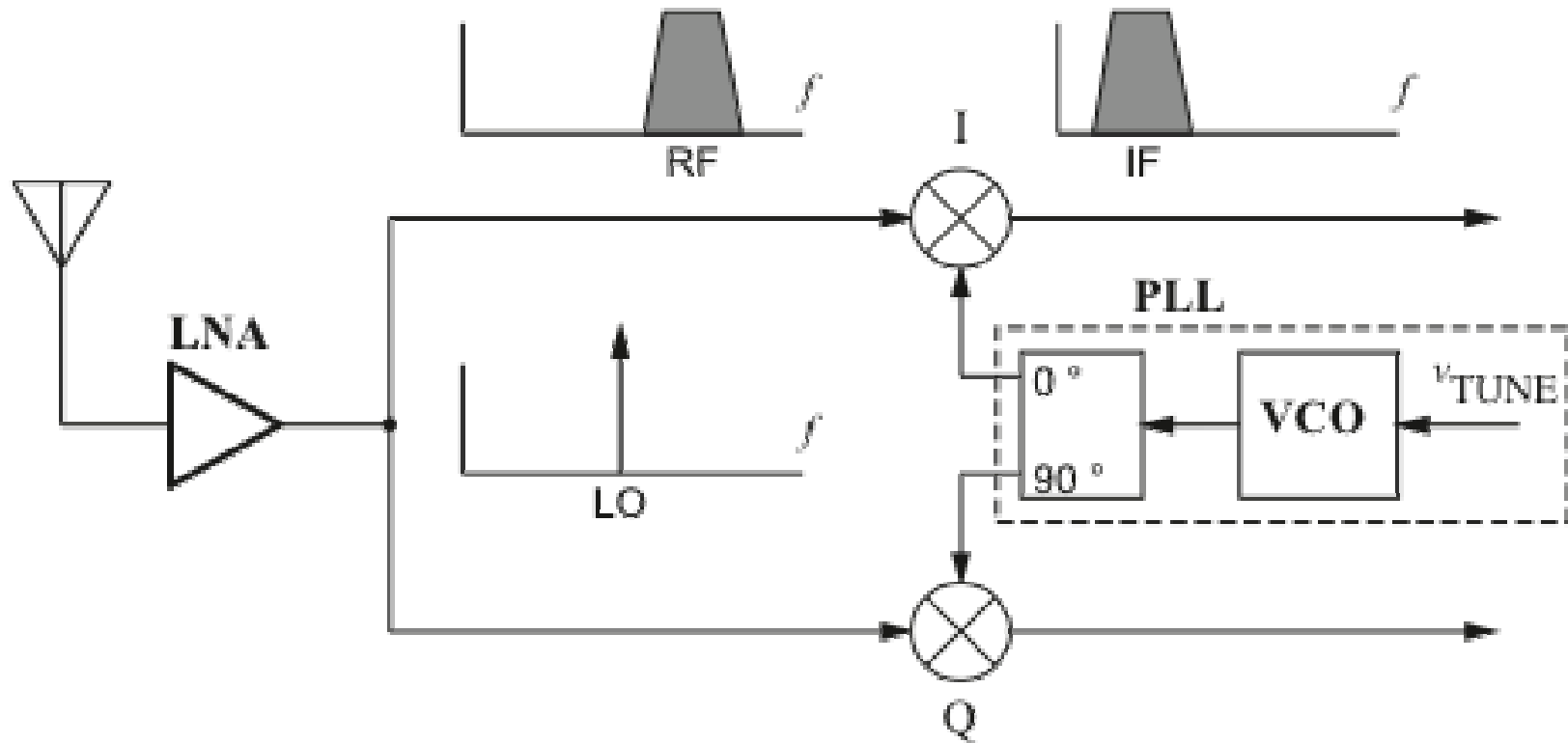

- Downconvert band of interest to IF
- VCO: Electrically tunable selection

Applications: Digital System

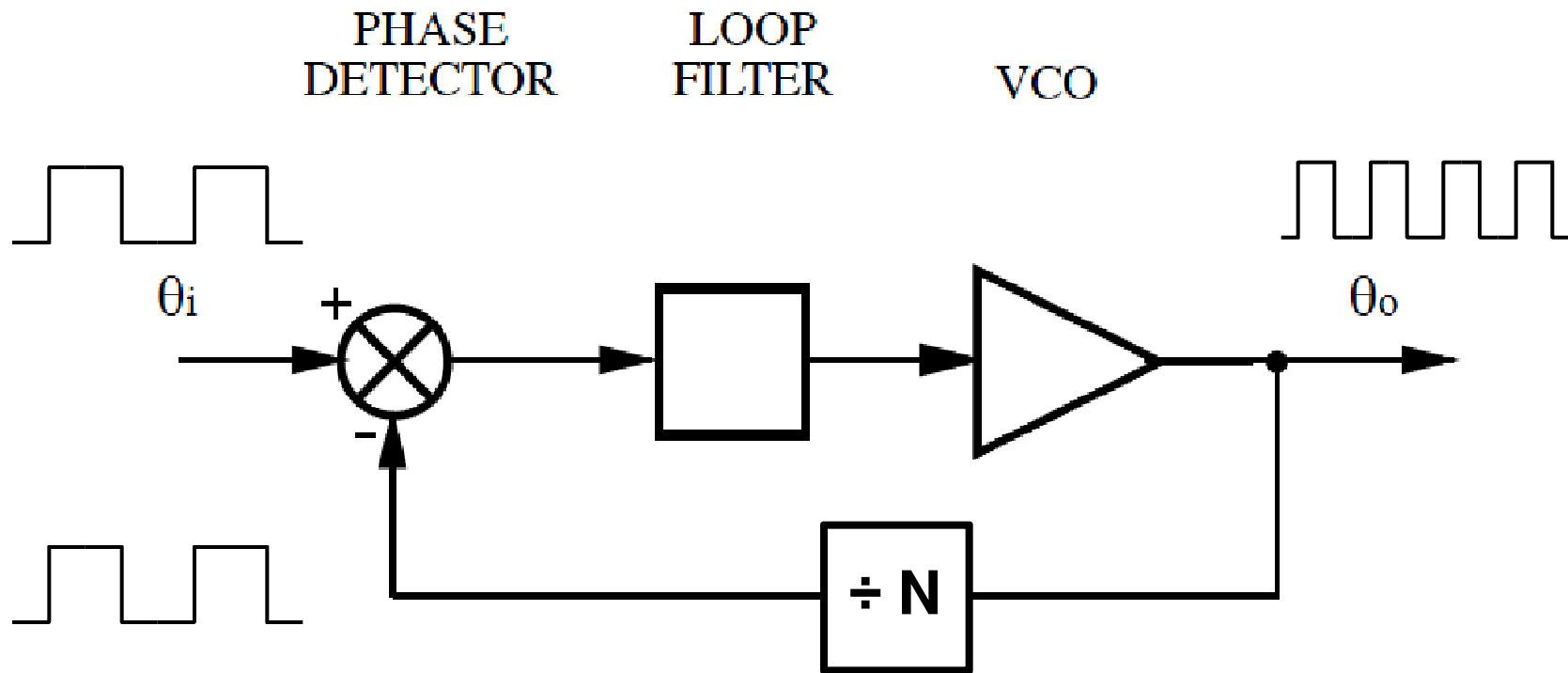

- **Clock synthesis (frequency multiplication)**

J. A. McNeill and D. R. Ricketts, "The Designer's Guide to Jitter in Ring Oscillators." Springer, 2009

Specifications

VOLTAGE CONTROLLED OSCILLATORS 50 Ω

12.5 MHz to 3 GHz



MODEL PREFIX	FREQUENCY (MHz)		POWER OUTPUT (dBm)	TUNE VOLTAGE (V)		PHASE NOISE (dBc/Hz) SSB@ offset frequencies: Typ.				PULLING (MHz) pk-pk @12 dB	PUSHING (MHz/V)	TUNING SENSITIVITY (MHz/V)	HARMONICS (dBc)		3dB MOD. BANDWIDTH (kHz)	POWER SUPPLY	
	Min.	Max.		Typ.	Min.	Max.	1 kHz	10 kHz	100 kHz				1 MHz	Typ.		Max.	Typ.

LINEAR TUNING Wideband

JCOS-175LN	125	175	+3.7	1.0	17.0	-95	-118	-138	-158	0.08	0.05	3-5	-25	-20	2900	12.0	20
JCOS-820BLN	807	832	+3.0	1.0	14.0	-88	-112	-132	-151	0.4	0.4	6.0	-24	-20	2000	10.0	25
JCOS-820WLN	780	860	+9.0	0.0	20.0	-90	-112	-132	-150	4.5	0.3	8.0	-13	-8	2000	9.0	25
JCOS-1110LN	1079	1114	+8.5	0.0	20.0	-88	-110	-130	-150	7.5	0.5	4.5	-15	-10	2000	8.0	25
JTOS-25	12.5	25	+8.0	1.0	11.0	-95	-115	-135	-155	0.03	0.02	1.0-4.0	-26	-13	130	12.0	20
JTOS-50	25	47	+8.5	1.0	15.0	-88	-108	-127	-147	0.06	0.04	2.0-2.6	-19	-12	50	12.0	20
JTOS-75	37.5	75	+8.0	1.0	16.0	-89	-110	-130	-140	0.15	0.11	2.8-4.0	-27	-20	125	12.0	20
JTOS-100	50	100	+8.3	1.0	16.0	-83	-108	-128	-140	0.6	0.2	3.7-4.8	-35	-20	100	12.0	18
JTOS-150	75	150	+9.5	1.0	16.0	-82	-106	-127	-147	0.8	0.3	5.8-6.7	-23	-17	112	12.0	20
JTOS-200	100	200	+10.0	1.0	16.0	-84	-105	-124	-145	1.0	0.2	6-10	-25	-20	110	12.0	20
JTOS-300	150	280	+9.0	1.0	16.0	-82	-102	-122	-142	1.0	0.2	9-14	-28	-20	120	12.0	20
JTOS-400	200	380	+9.0	1.0	16.0	-82	-102	-122	-142	1.4	0.4	10.5-17.1	-25	-20	130	12.0	20
JTOS-535	300	525	+9.5	1.0	16.0	-75	-97	-117	-137	2.0	0.5	10-24	-28	-20	115	12.0	20
JTOS-765	485	765	+8.0	1.0	16.0	-75	-98	-118	-138	2.0	0.5	20-30	-30	-20	100	12.0	20
JTOS-850VW	400	850	+6.0	0.5	18.0	-74	-96	-116	-136	6.0	1.5	15-80	-20	—	185	5.0	20
JTOS-1000W	500	1000	+7.0	1.0	18.0	-73	-94	-114	-134	5.0	1.0	30-40	-26	-20	100	12.0	25

Overview

- **Functional Block Concept**
- **Oscillator Review**
 - **Frequency Control**
 - **Amplitude Control**
 - **Types of Oscillators**
- **Basic Performance Metrics**
- **Methods of Tuning**
- **Advanced Performance Metrics**
- **Conclusion**

Oscillator Review

- **Types of Oscillators**
 - Multivibrator
 - Ring
 - Resonant
 - Feedback
- **Basic Factors in Oscillator Design**
 - Frequency
 - Amplitude / Output Power
 - Startup

Multivibrator

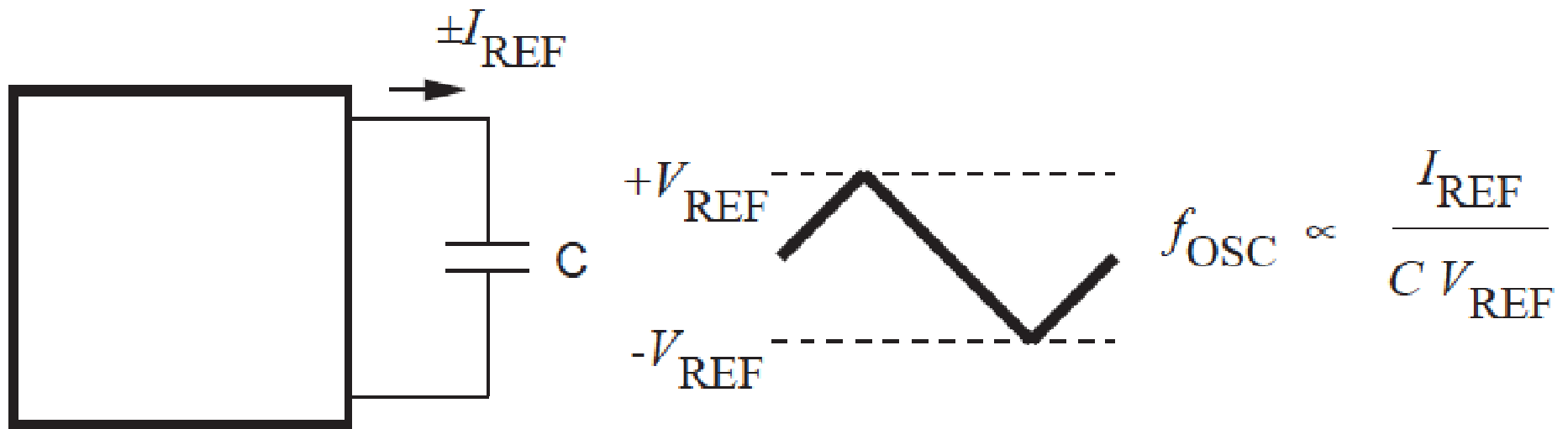

- **Conceptual multivibrator oscillator**
 - Also called astable or relaxation oscillator
- **One energy storage element**

Example: Multivibrator

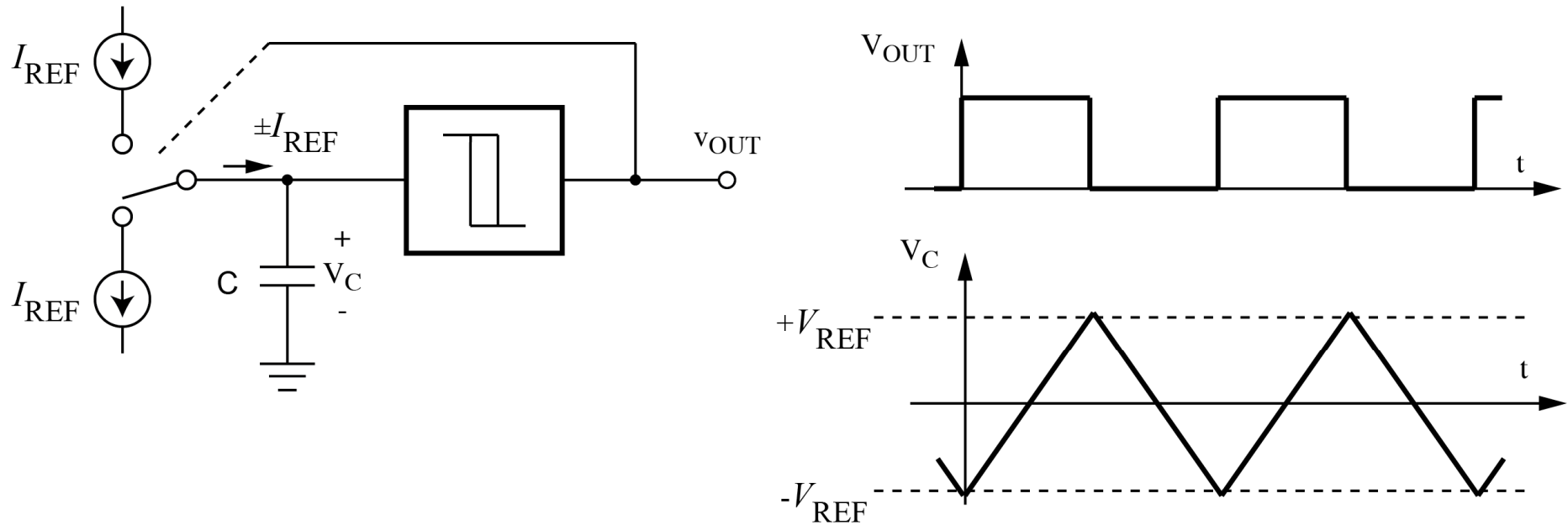

- **Frequency:** Controlled by charging current I_{REF} , C , V_{REF} thresholds
- **Amplitude:** Controlled by thresholds, logic swing
- **Startup:** Guaranteed; no stable state

Ring Oscillator

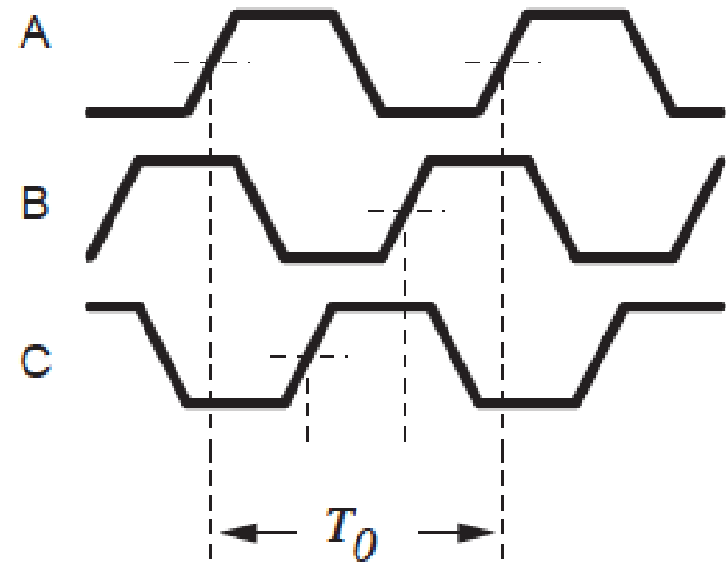
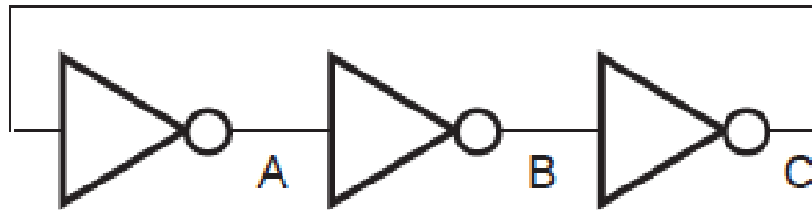

- **Frequency: Controlled by gate delay**
- **Amplitude: Controlled by logic swing**
- **Startup: Guaranteed; no stable state**

Resonant Oscillator

- **Concept: Natural oscillation frequency of resonance**
- **Energy flows back and forth between two storage modes**

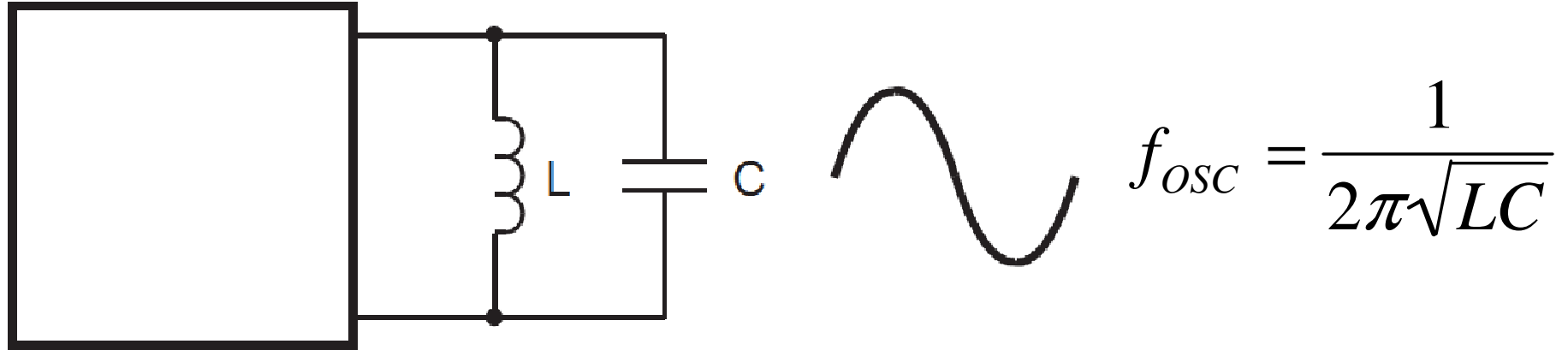

Resonant Oscillator (Ideal)

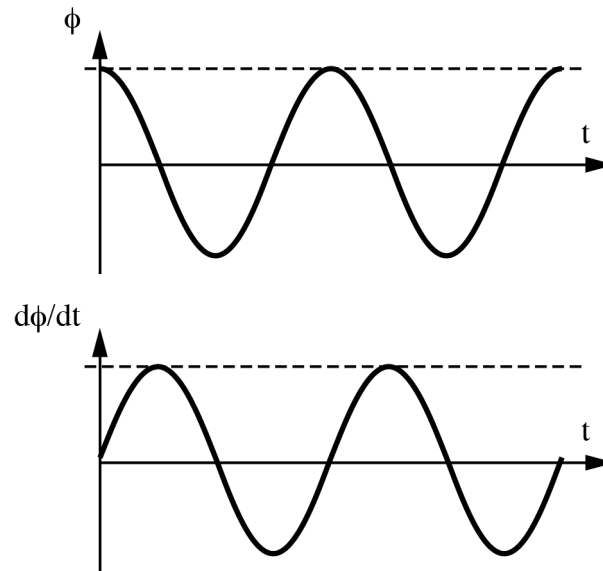
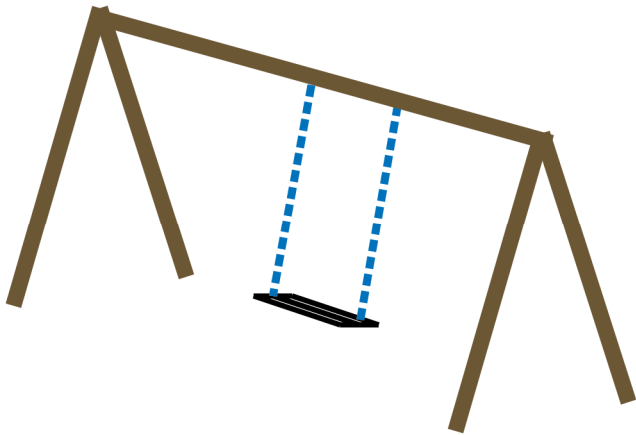

- **Example: swing (ideal)**
- **Energy storage modes: potential, kinetic**
- **Frequency: Controlled by length of pendulum**
- **Amplitude: Controlled by initial position**
- **Startup: Needs initial condition energy input**

Resonant Oscillator (Real)

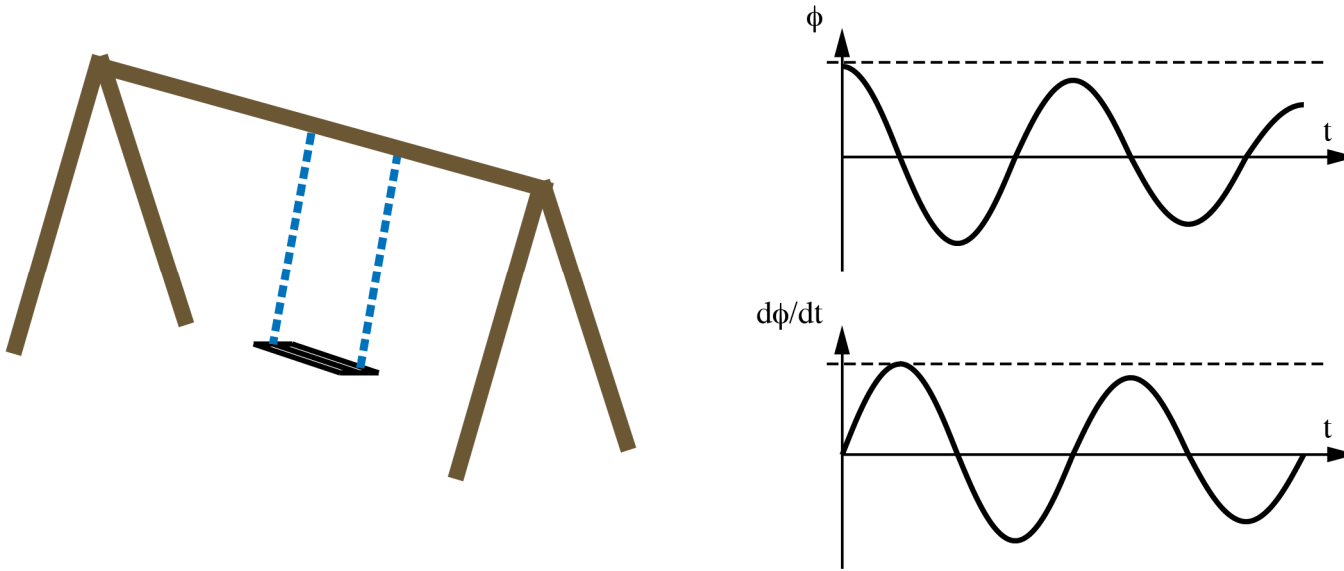

- **Problem: Loss of energy due to friction**
- **Turns “organized” energy (potential, kinetic) into “disorganized” thermal energy (frictional heating)**
- **Amplitude decays toward zero**
- **Requires energy input to maintain amplitude**
- **Amplitude controlled by “supervision”**

LC Resonant Oscillator (Ideal)

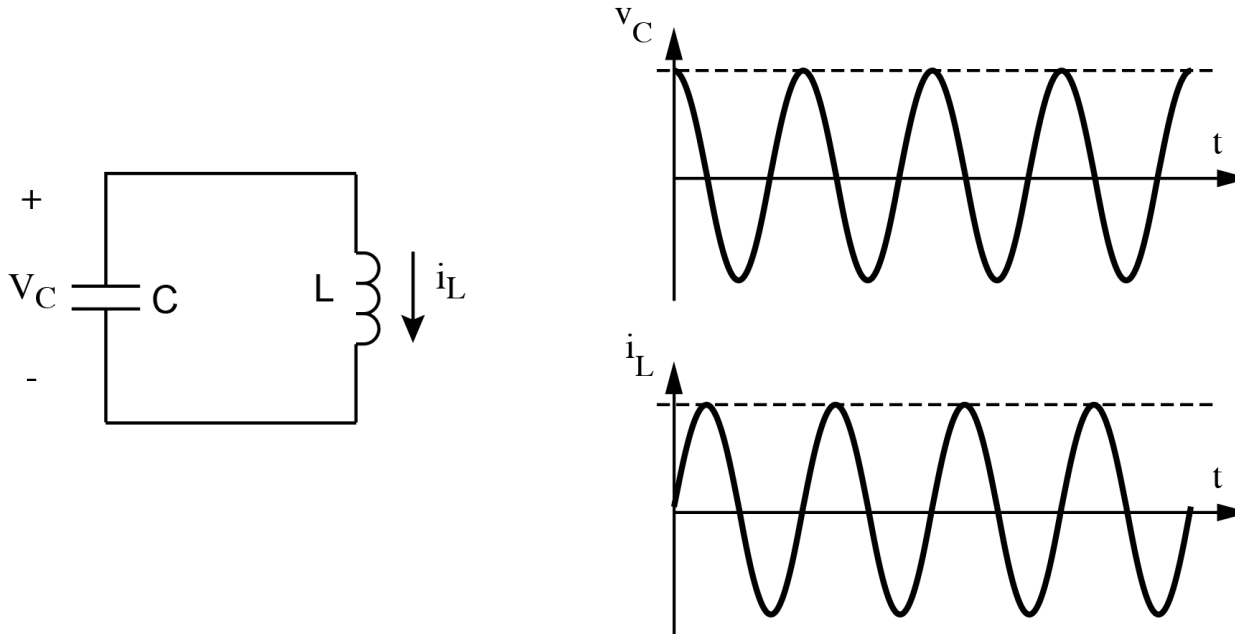

- **Energy storage modes:**
Magnetic field (L current), Electric field (C voltage)
- **Frequency: Controlled by LC**
- **Amplitude: Controlled by initial condition**
- **Startup: Needs initial energy input (initial condition)**

LC Resonant Oscillator (Real)

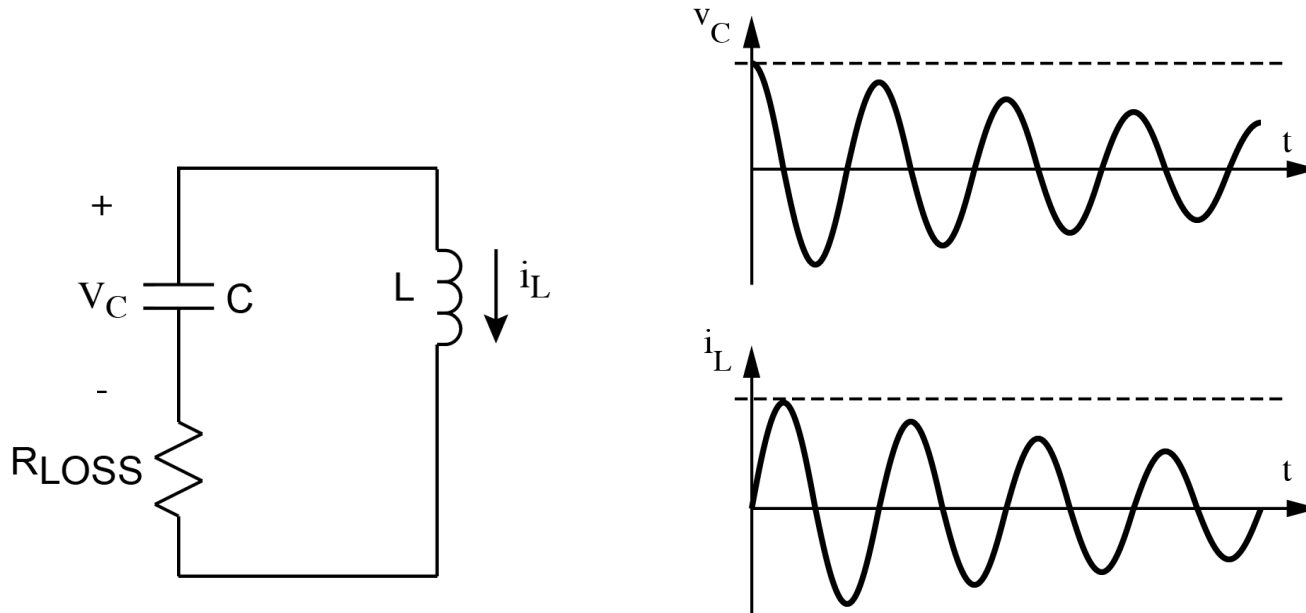

- **Problem: Loss of energy due to nonideal L, C**
 - Model as resistor R_{LOSS} ; Q of resonator
- **E, M field energy lost to resistor heating**
- **Amplitude decays toward zero**

LC Resonant Oscillator (Real)

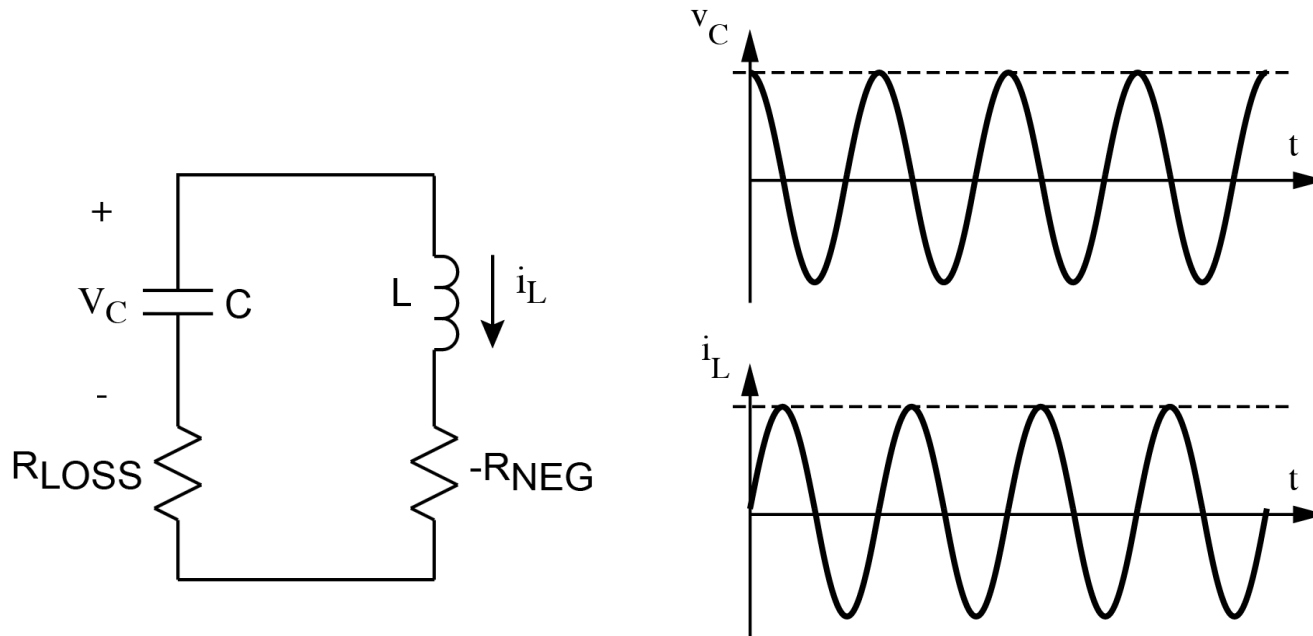

- **Problem: Loss of energy due to nonideal L, C**
- **Requires energy input to maintain amplitude**
- **Synthesize “negative resistance”**
- **Cancel R_{LOSS} with $-R_{NEG}$**

Negative Resistance

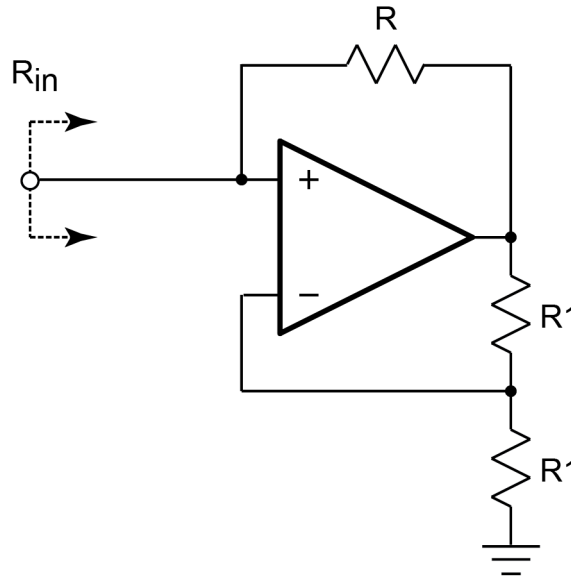

- Use active device to synthesize V-I characteristic that “looks like” $-R_{NEG}$
- Example: amplifier with positive feedback
- Feeds energy into resonator to counteract losses in R_{LOSS}

Feedback Oscillator: Wien Bridge

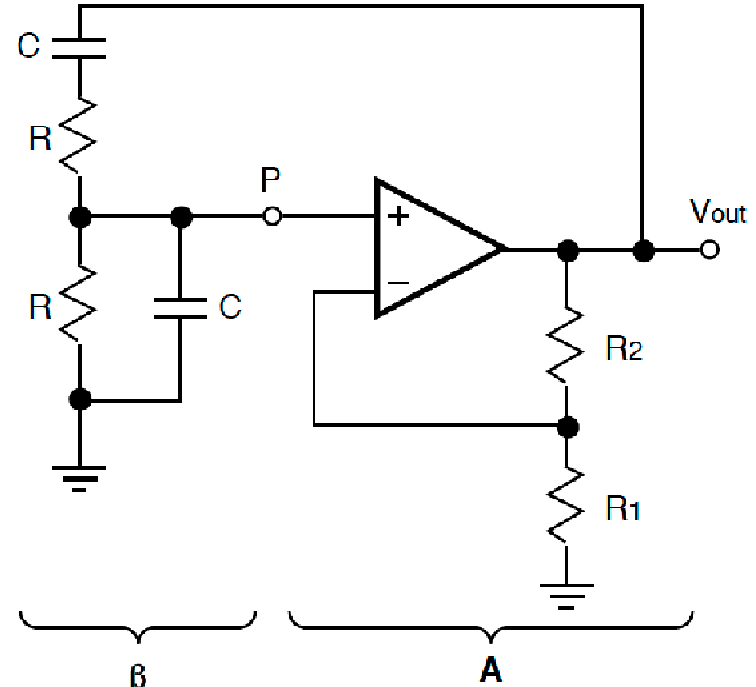
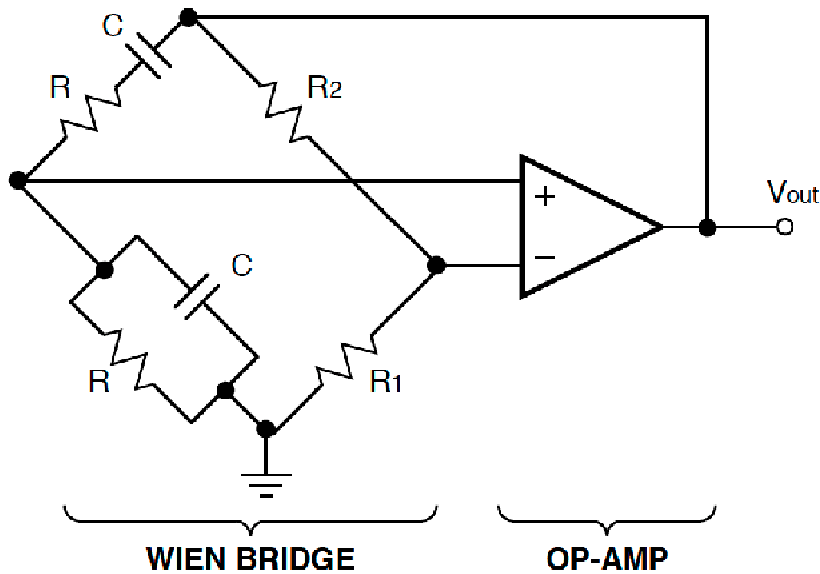

- Forward gain $A=3$
- Feedback network with transfer function $\beta(f)$
- At f_{osc} , $|\beta|=1/3$ and $\angle \beta = 0$
- Thought experiment: break loop, inject sine wave, look at signal returned around feedback loop

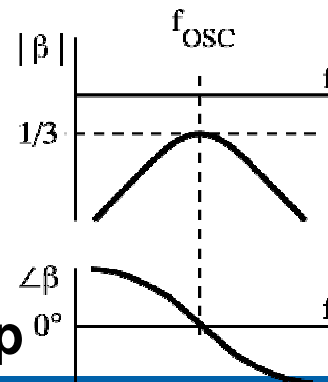

$A\beta=1$

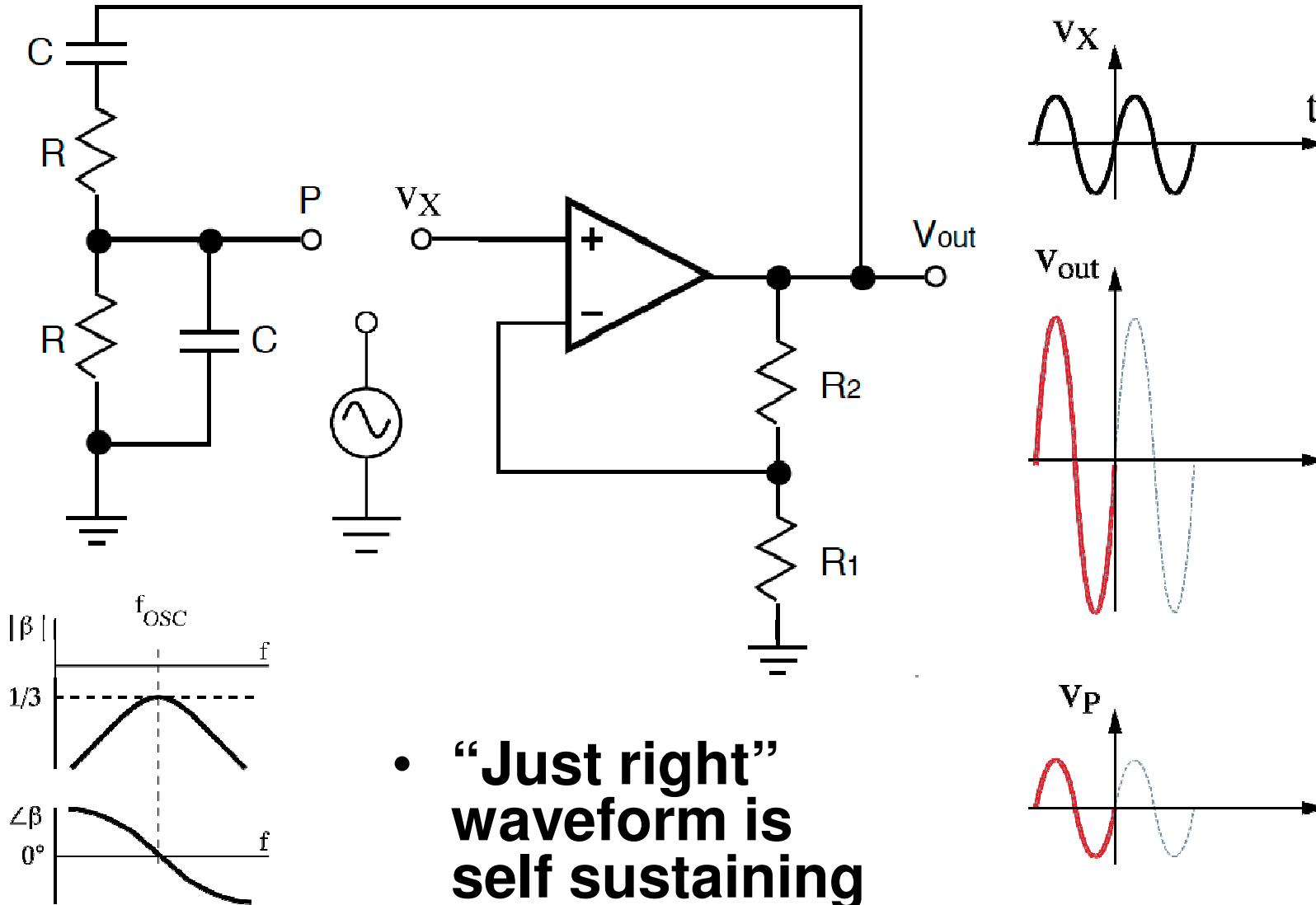

$A\beta = 0.99$

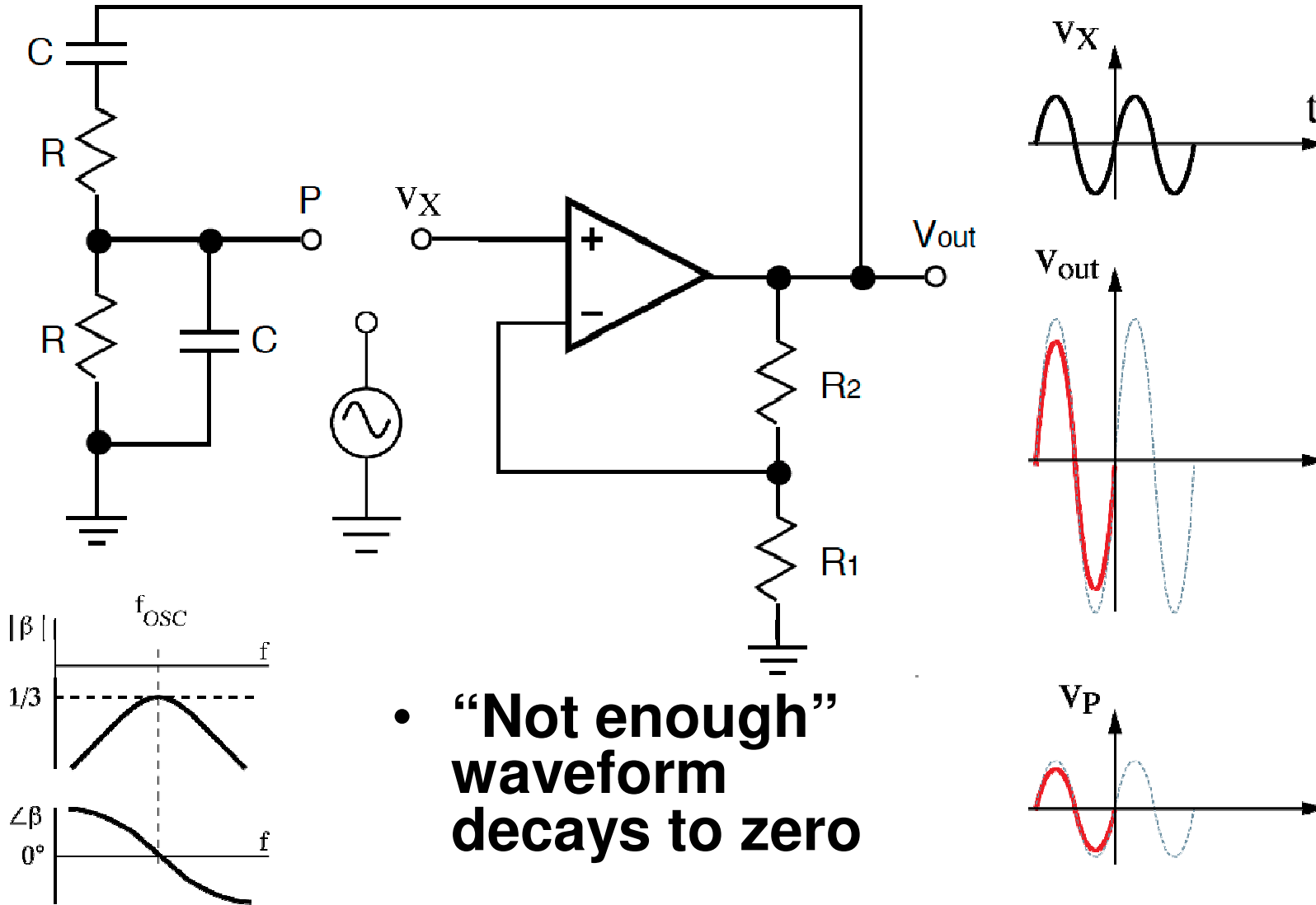

- **“Not enough” waveform decays to zero**

$A\beta = 1.01$

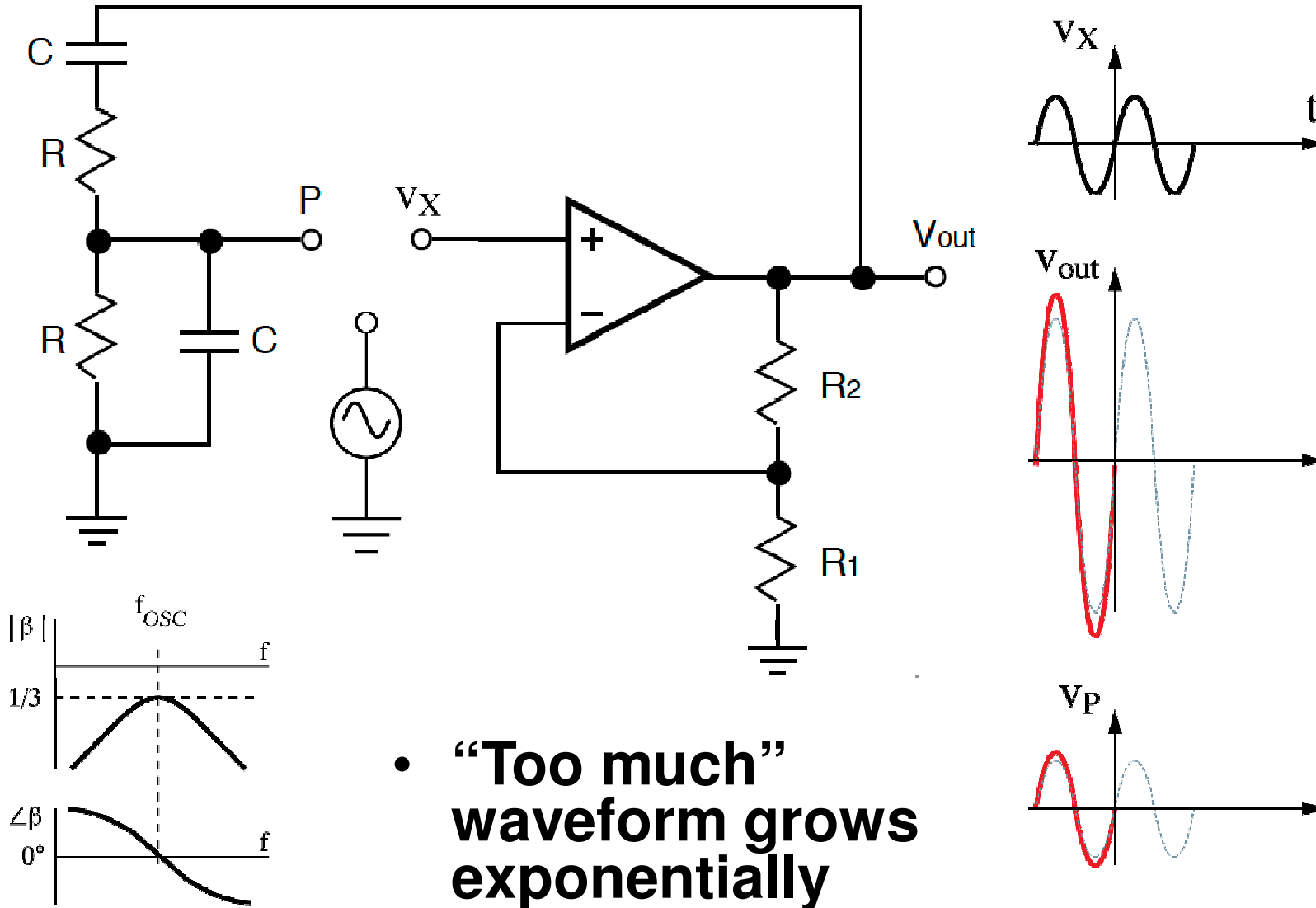

Feedback oscillator

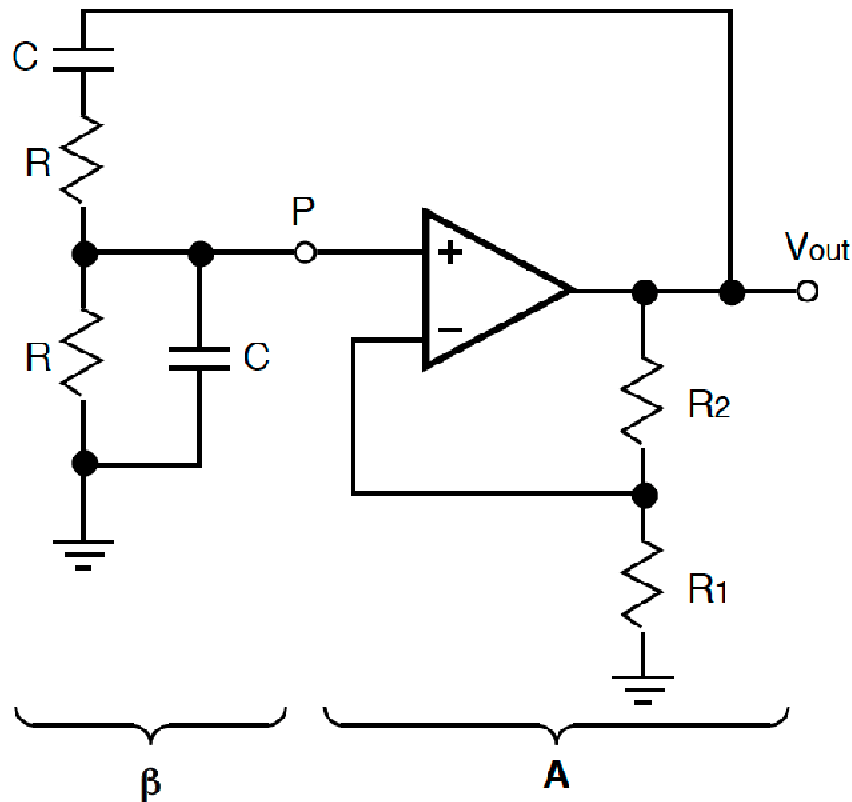

- **Stable amplitude condition: $A\beta=1$ EXACTLY**
- **Frequency determined by feedback network $A\beta=1$ condition**
- **Need supervisory circuit to monitor amplitude**
- **Startup: random noise; supervisory circuit begins with $A\beta>1$**

Resonant Oscillator (Real)

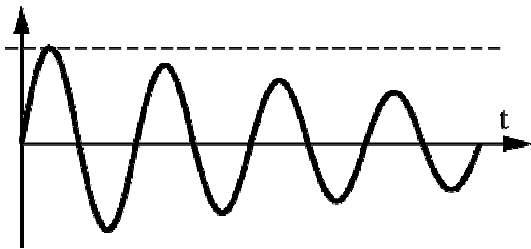
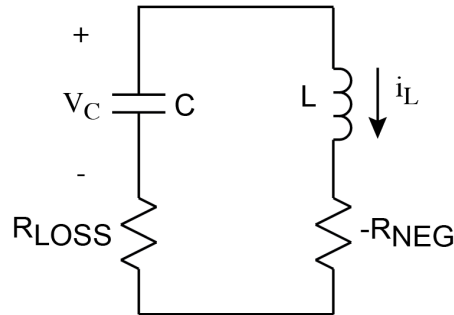

$$|R_{\text{NEG}}| < R_{\text{LOSS}}$$

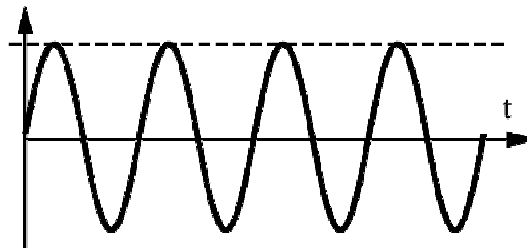

$$|R_{\text{NEG}}| = R_{\text{LOSS}}$$

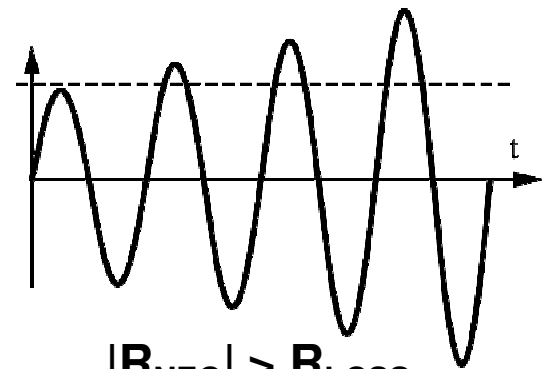

$$|R_{\text{NEG}}| > R_{\text{LOSS}}$$

- **Stable amplitude condition: $|R_{\text{NEG}}| = R_{\text{LOSS}}$ EXACTLY**
- **Frequency determined by LC network**
- **Startup: random noise; begin with $|R_{\text{NEG}}| > R_{\text{LOSS}}$**
- **Amplitude grows; soft clip gives average $|R_{\text{NEG}}| = R_{\text{LOSS}}$**

Clapp oscillator

$$f_{osc} = \frac{1}{2\pi\sqrt{LC_{eq}}}$$

$$C_{eq} = \frac{1}{\left(\frac{1}{C_1} + \frac{1}{C_2} + \frac{1}{C_3}\right)}$$

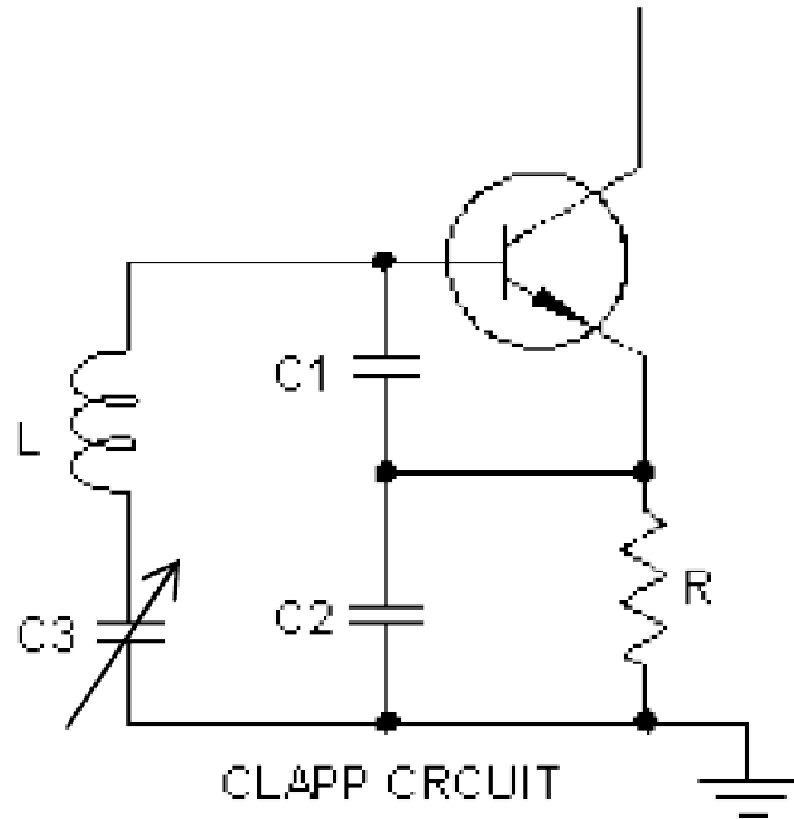

- **L, C1-C2-C3 set oscillation frequency f_{osc}**

Clapp oscillator

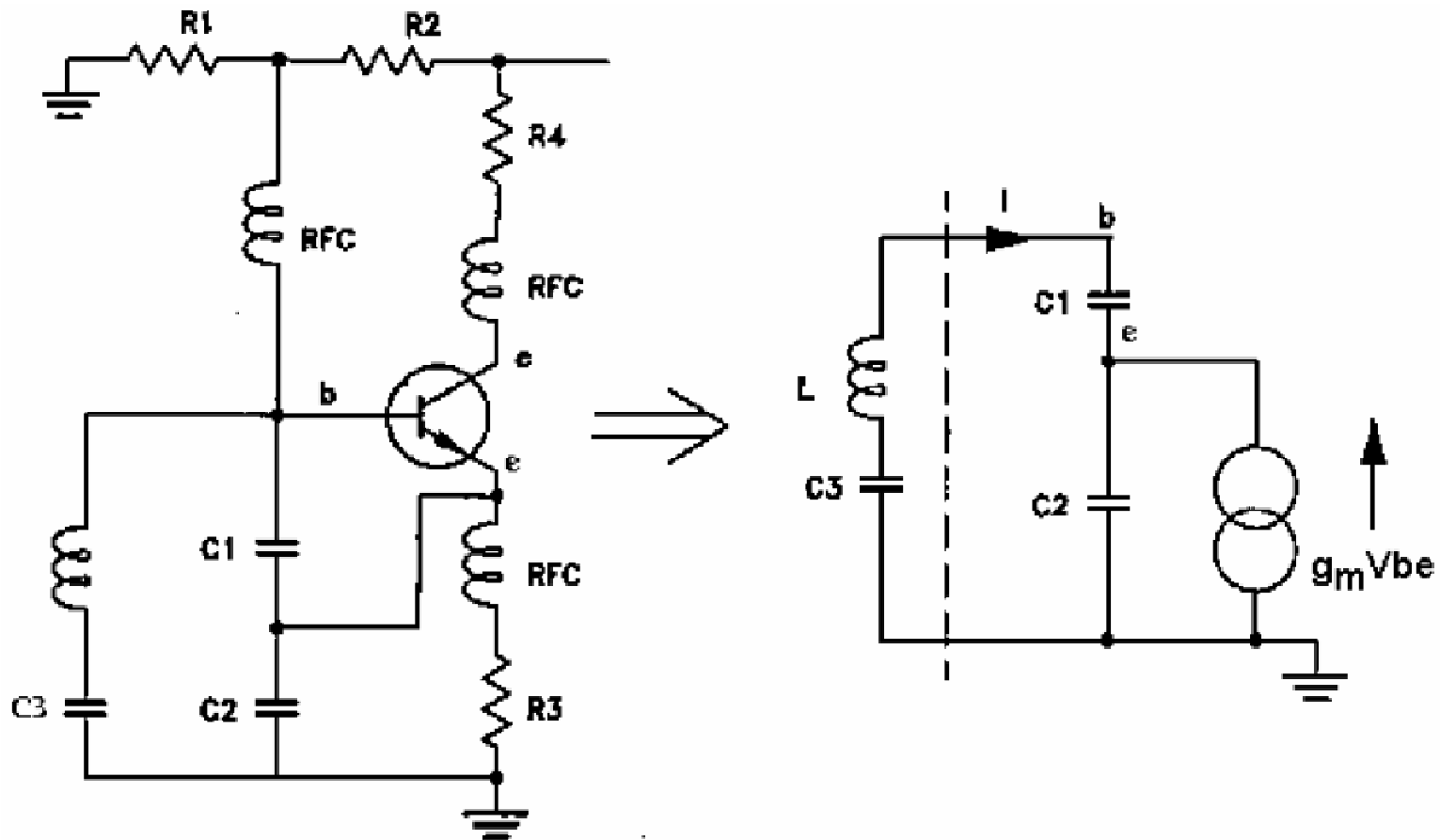

- **Circuit configuration**

- **Equivalent circuit**

MiniCircuits AN95-007, "Understanding Oscillator Concepts"

Clapp oscillator

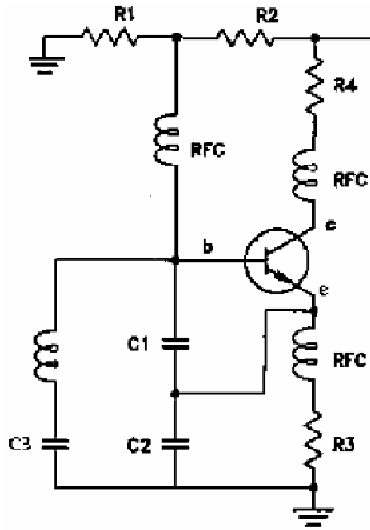

$$Z_{eq} = \frac{1}{j\omega C_1} + \frac{1}{j\omega C_2} - \frac{g_m}{\omega^2 C_1 C_2}$$

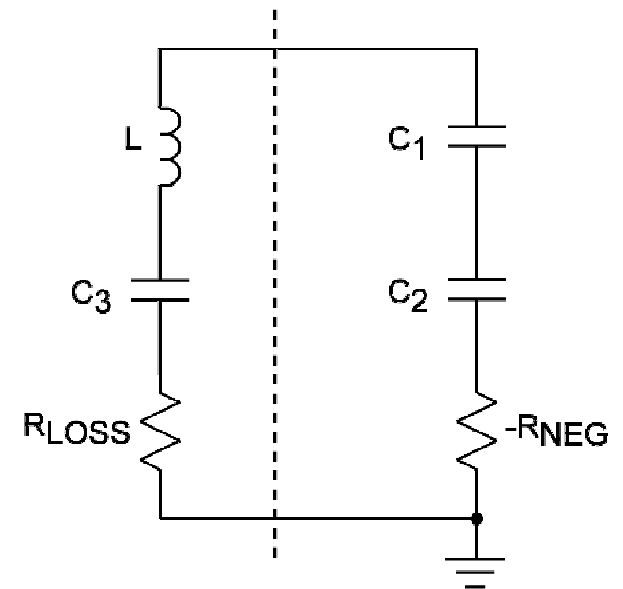
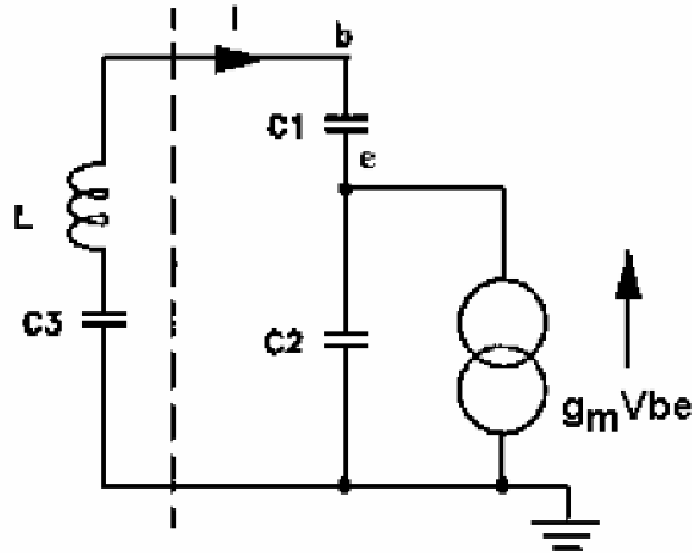

- **Frequency:** Determined by L, C1, C2, C3
- **Amplitude:** Grows until limited by g_m soft clipping
- **Startup:** Choose C1, C2 feedback for $|R_{NEG}| > R_{LOSS}$

Oscillator Summary

- Typical performance of oscillator architectures:

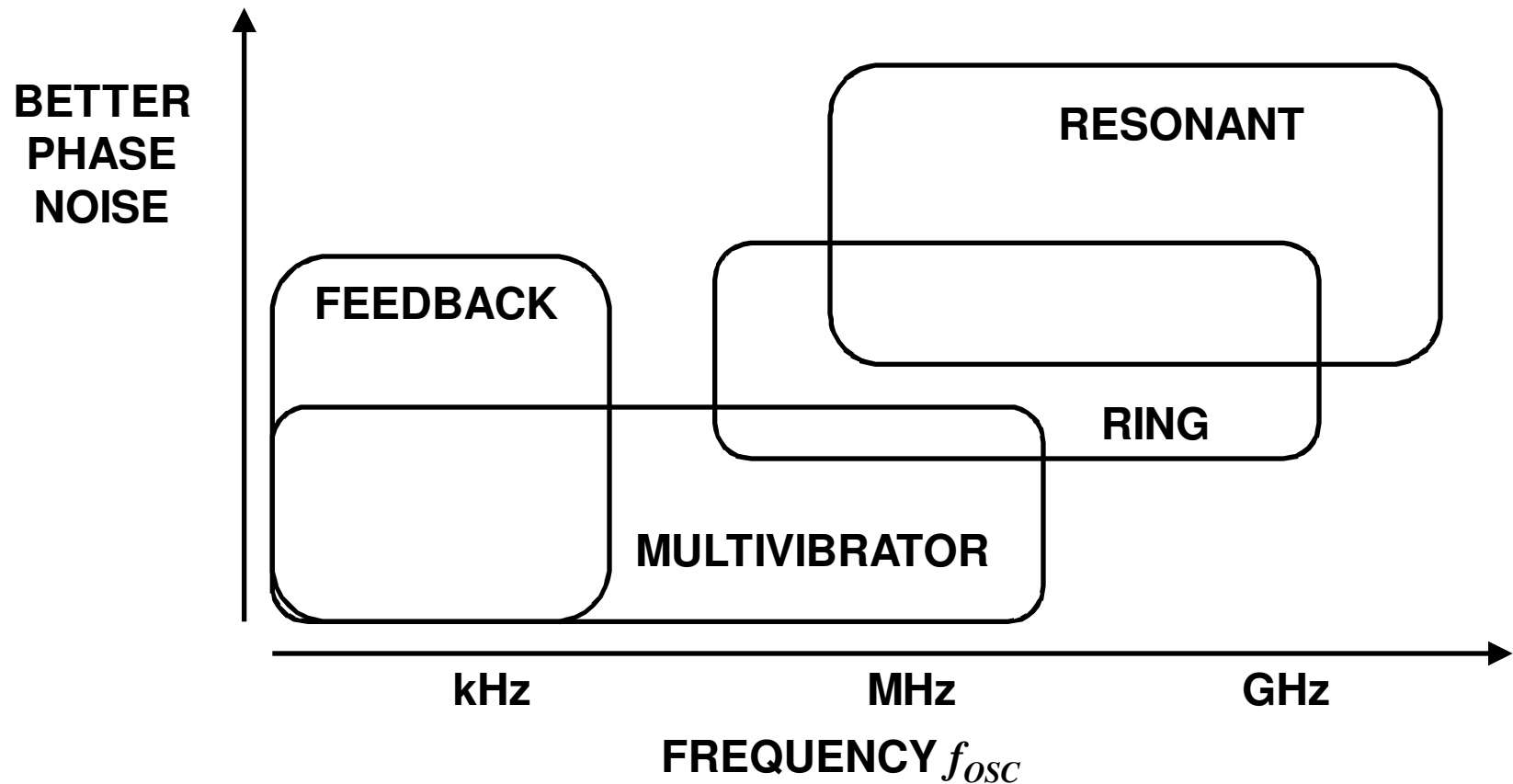

Overview

- Functional Block Concept
- Oscillator Review
- **Basic Performance Metrics**
 - Frequency Range
 - Tuning Range
- Methods of Tuning
- Advanced Performance Metrics
- Conclusion

Basic Performance Metrics

VOLTAGE CONTROLLED OSCILLATORS 50 Ω

12.5 MHz to 3 GHz



MODEL PREFIX	FREQUENCY (MHz)		POWER OUTPUT (dBm)	TUNE VOLTAGE (V)		PHASE NOISE (dBc/Hz) SSB@ offset frequencies: Typ.				PULLING (MHz) pk-pk @12 dB	PUSHING (MHz/V)	TUNING SENSITIVITY (MHz/V)	HARMONICS (dBc)		3dB MOD. BANDWIDTH (kHz)	POWER SUPPLY	
	Min.	Max.		Min.	Max.	1 kHz	10 kHz	100 kHz	1 MHz				Typ.	Typ.		Typ.	Typ.

LINEAR TUNING Wideband

JCOS-175LN	125	175	+3.7	1.0	17.0	-95	-118	-138	-158	0.08	0.05	3-5	-25	-20	2900	12.0	20
JCOS-820BLN	807	832	+3.0	1.0	14.0	-88	-112	-132	-151	0.4	0.4	6.0	-24	-20	2000	10.0	25
JCOS-820WLN	780	860	+9.0	0.0	20.0	-90	-112	-132	-150	4.5	0.3	8.0	-13	-8	2000	9.0	25
JCOS-11100LN	1079	1114	+8.5	0.0	20.0	-88	-110	-130	-150	7.5	0.5	4.5	-15	-10	2000	8.0	25
JTOS-25	12.5	25	+8.0	1.0	11.0	-95	-115	-135	-155	0.03	0.02	1.0-4.0	-26	-13	130	12.0	20
JTOS-50	25	47	+8.5	1.0	15.0	-88	-108	-127	-147	0.06	0.04	2.0-2.6	-19	-12	50	12.0	20
JTOS-75	37.5	75	+8.0	1.0	16.0	-89	-110	-130	-140	0.15	0.11	2.8-4.0	-27	-20	125	12.0	20
JTOS-100	50	100	+8.3	1.0	16.0	-83	-108	-128	-140	0.6	0.2	3.7-4.8	-35	-20	100	12.0	18
JTOS-150	75	150	+9.5	1.0	16.0	-82	-106	-127	-147	0.8	0.3	5.8-6.7	-23	-17	112	12.0	20
JTOS-200	100	200	+10.0	1.0	16.0	-84	-105	-124	-145	1.0	0.2	6-10	-25	-20	110	12.0	20
JTOS-300	150	280	+9.0	1.0	16.0	-82	-102	-122	-142	1.0	0.2	9-14	-28	-20	120	12.0	20
JTOS-400	200	380	+9.0	1.0	16.0	-82	-102	-122	-142	1.4	0.4	10.5-17.1	-25	-20	130	12.0	20
JTOS-535	300	525	+9.5	1.0	16.0	-75	-97	-117	-137	2.0	0.5	10-24	-28	-20	115	12.0	20
JTOS-765	485	765	+8.0	1.0	16.0	-75	-98	-118	-138	2.0	0.5	20-30	-30	-20	100	12.0	20
JTOS-850VW	400	850	+6.0	0.5	18.0	-74	-96	-116	-136	6.0	1.5	15-80	-20	—	185	5.0	20
JTOS-1000W	500	1000	+7.0	1.0	18.0	-73	-94	-114	-134	5.0	1.0	30-40	-26	-20	100	12.0	25

Basic Performance Metrics

Surface Mount

Voltage Controlled Oscillator

JTOS-1000W+

Wide Band 500 to 1000 MHz

Features

- wide frequency range, 500 to 1000 MHz typ.
- 3 dB modulation bandwidth 100 kHz typ.
- octave, linear tuning
- low phase noise, -134 dBc/Hz at 1 MHz offset, typ.
- excellent harmonic suppression, -26 dBc typ.
- aqueous washable

Applications

- test instruments-signal generators
- wideband frequency synthesizers
- agile communications systems
- catv distribution and set-top convertors
- cellular up and down converters
- digital cordless phones



CASE STYLE: BK377
PRICE: \$21.95 ea. QTY (5-49)

+RoHS Compliant

The +Suffix identifies RoHS Compliance. See our web site for RoHS Compliance methodologies and qualifications

Electrical Specifications

FREQUENCY (MHz)		POWER OUTPUT (dBm)	TUNING VOLTAGE (V)		PHASE NOISE (dBc/Hz) SSB at offset frequencies: Typ.				PULLING pk-pk @ 12 dB (MHz)	PUSHING (MHz/V)	TUNING SENSITIVITY (MHz/V)	HARMONICS (dBc)		3 dB MODULATION BANDWIDTH (MHz)	DC OPERATING POWER	
Min.	Max.	Typ.	Min.	Max.	1 kHz	10 kHz	100 kHz	1 MHz	Typ.	Typ.	Typ.	Typ.	Max.	Typ.	Vcc (volts)	Current (mA) Max.
500	1000	+7.0	1.0	18	-73	-94	-114	-134	5.0	1.0	30-40	-26	-20	0.1	12	25

Basic Performance Metrics

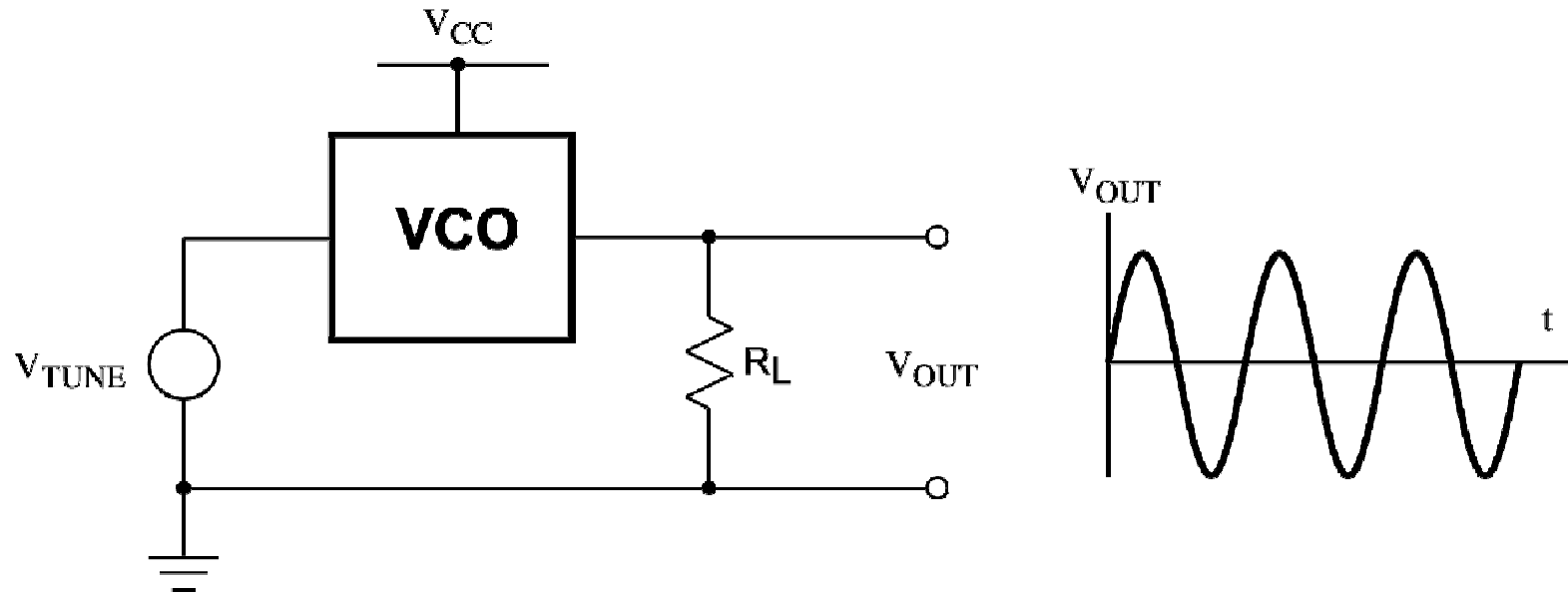

- **Supply:** DC operating power
- **Output**
 - Sine: output power dBm into 50Ω
 - Square: compatible logic
- **Frequency Range**
- **Tuning Voltage Range**

Frequency Range

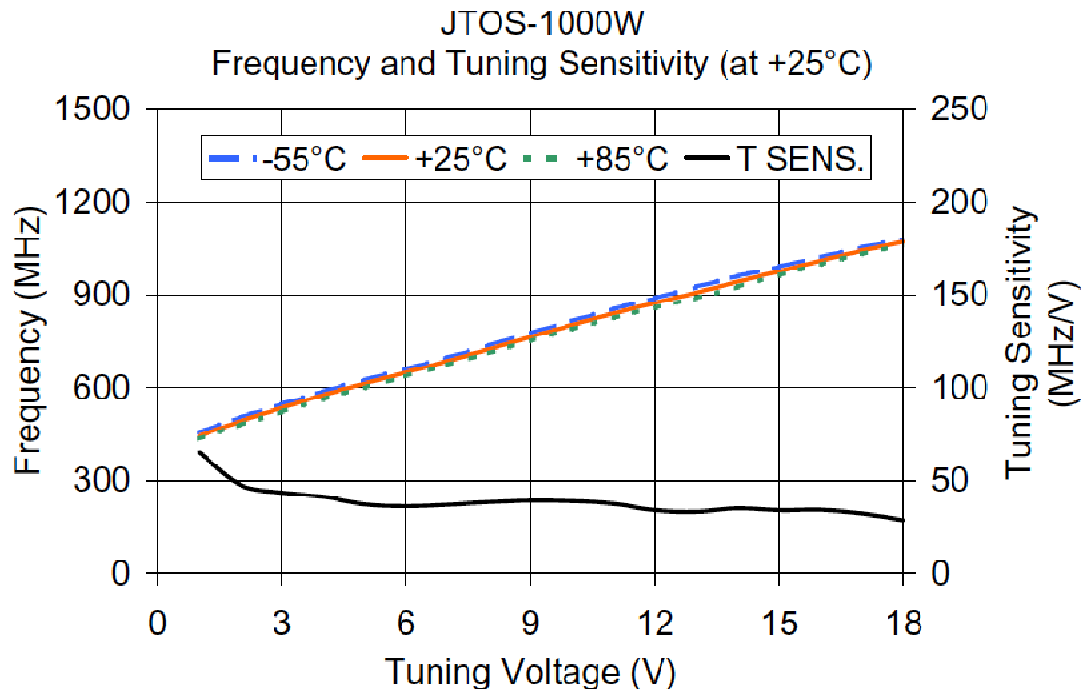

V TUNE	TUNING SENS. (MHz/V)	FREQUENCY (MHz)		
		-55°C	+25°C	+85°C
1.00	65.31	455.40	443.44	433.76
2.00	47.64	503.88	491.08	480.00
3.00	43.38	546.43	534.46	521.76
4.00	41.23	587.53	575.68	562.24
5.00	37.18	624.47	612.87	600.23
6.00	36.00	660.47	648.87	636.80
7.00	36.98	697.54	685.84	673.93
8.00	38.32	736.41	724.17	711.94
9.00	39.19	775.71	763.36	750.82
10.00	38.93	815.33	802.29	789.02
11.00	37.42	854.60	839.71	825.08
12.00	33.97	889.31	873.67	857.98
13.00	33.20	925.48	906.87	889.55
14.00	35.13	960.60	942.00	925.73
15.00	33.97	991.30	975.97	963.00
16.00	34.17	1022.17	1010.14	999.00
17.00	32.21	1052.63	1042.35	1031.78
18.00	28.65	1081.03	1070.99	1060.58

- Output frequency over tuning voltage range
- Caution: Temperature sensitivity

Overview

- Functional Block Concept
- Oscillator Review
- Basic Performance Metrics
- **Methods of Tuning**
- Advanced Performance Metrics
- Conclusion

VCOs / Methods of Tuning

- Require electrical control of some parameter determining frequency:

- **Multivibrator**

- Charge / discharge current

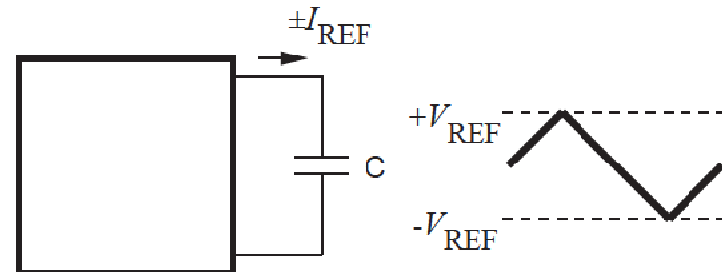

- **Ring Oscillator**

- Gate delay

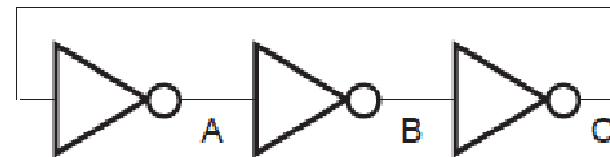

- **Resonant**

- Voltage control of capacitance in LC (varactor)

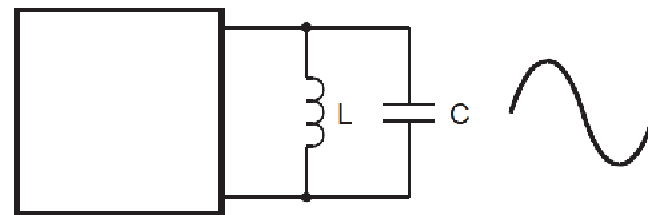

Example: Tuning Multivibrator

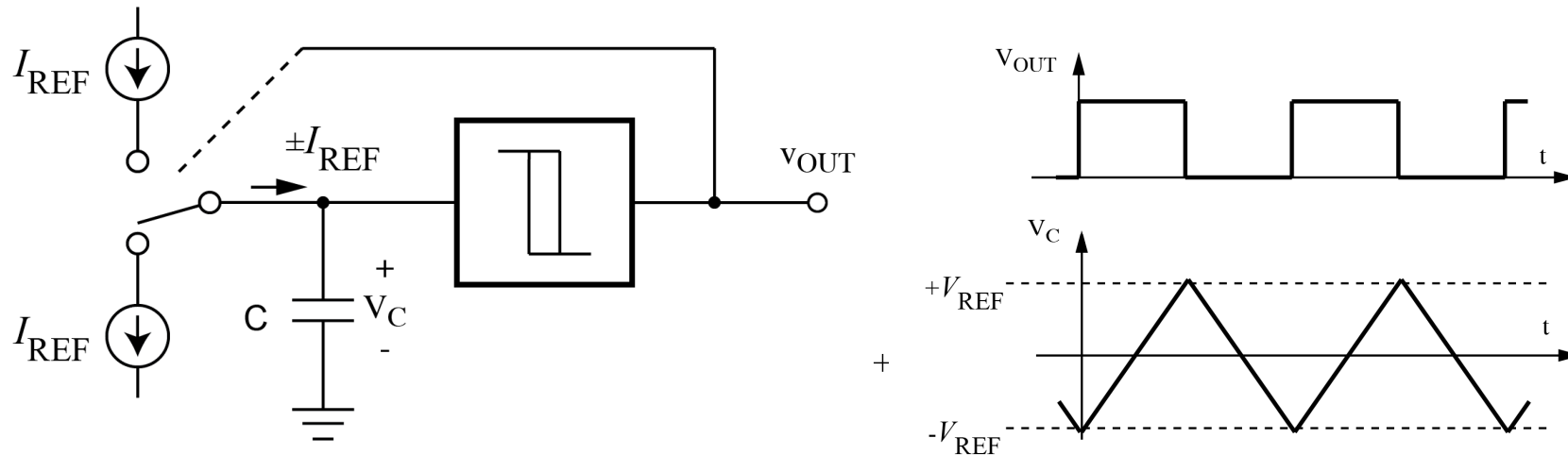

- **Frequency: Controlled by I_{REF} , C , V_{REF} thresholds**
- **Use linear transconductance G_M to develop I_{REF} from V_{TUNE}**

$$f_{OSC} = \frac{I_{REF}}{4CV_{REF}}$$

$$I_{REF} = G_M V_{TUNE}$$

+ **Very linear $V_{TUNE} - f_{OSC}$ characteristic**

$$f_{OSC} = \left(\frac{G_M}{4CV_{REF}} \right) V_{TUNE}$$

- **But: poor phase noise; f_{OSC} limited to MHz range**

Tuning LC Resonator: Varactor

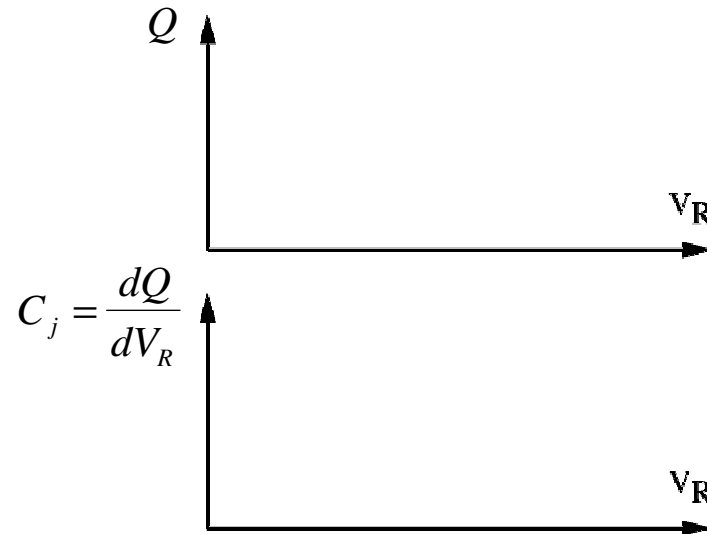
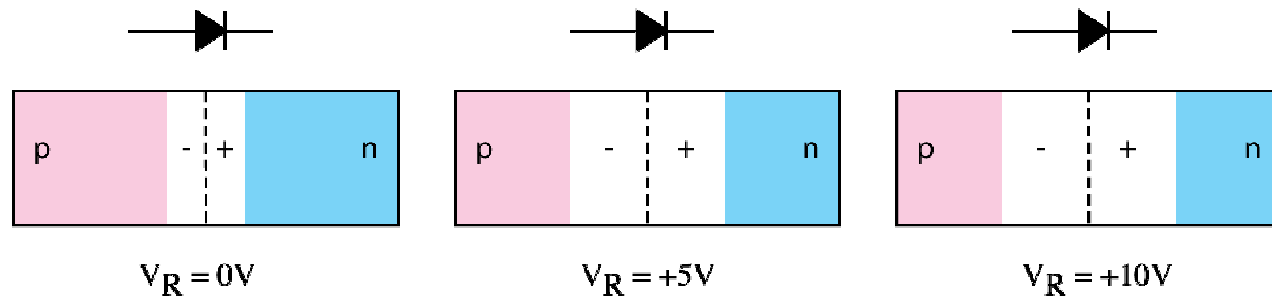

$$C_j = \frac{C_{j0}}{\left(1 + \frac{V_R}{V_{bi}}\right)^m}$$

- Q-V characteristic of pn junction
- Use reverse bias diode for C in resonator

Example: Clapp oscillator

$$f_{osc} = \frac{1}{2\pi\sqrt{LC_{TUNE}}} \sqrt{1 + \frac{C_{TUNE}}{C_1} + \frac{C_{TUNE}}{C_2}}$$

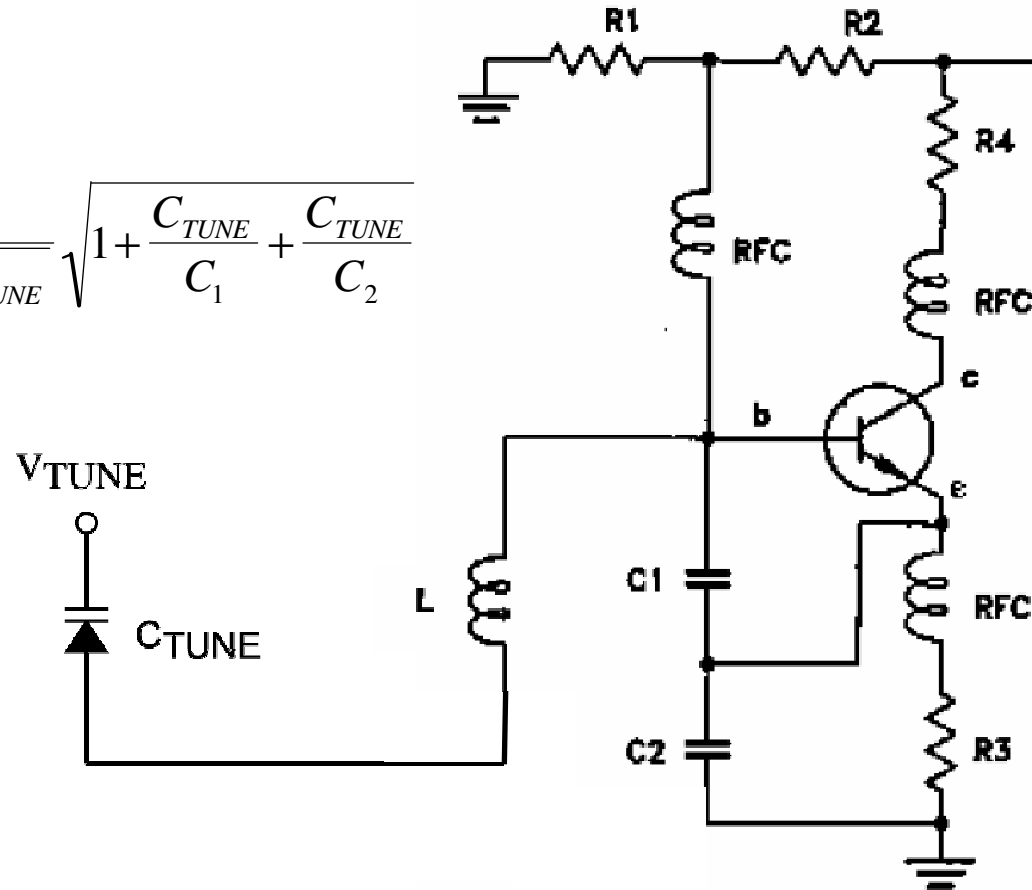

- Tuning range f_{MIN} , f_{MAX} set by C_{TUNE} maximum, minimum
- Want $C_1, C_2 > C_{TUNE}$ for wider tuning range

Overview

- Functional Block Concept
- Oscillator Review
- Basic Performance Metrics
- Methods of Tuning
- **Advanced Performance Metrics**
 - **Tuning Sensitivity**
 - **Phase Noise**
 - **Supply Pushing**
 - **Load Pulling**
- Conclusion

Advanced Performance Metrics

VOLTAGE CONTROLLED OSCILLATORS $50\ \Omega$

12.5 MHz to 3 GHz



MODEL PREFIX	FREQUENCY (MHz)		POWER OUTPUT (dBm)	TUNE VOLTAGE (V)		PHASE NOISE (dBc/Hz) SSB@ offset frequencies: Typ.				PULLING (MHz) pk-pk @12 dB	PUSHING (MHz/V) Typ.	TUNING SENSITIVITY (MHz/V) Typ.	HARMONICS (dBc)		3dB MOD. BANDWIDTH (kHz) Typ.	POWER SUPPLY	
	Min.	Max.		Typ.	Min.	Max.	1 kHz	10 kHz	100 kHz				1 MHz	Typ.		Max.	Voltage (V) Nom.

LINEAR TUNING Wideband

JCOS-175LN	125	175	+3.7	1.0	17.0	-95	-118	-138	-158	0.08	0.05	3-5	-25	-20	2900	12.0	20
JCOS-820BLN	807	832	+3.0	1.0	14.0	-88	-112	-132	-151	0.4	0.4	6.0	-24	-20	2000	10.0	25
JCOS-820WLN	780	860	+9.0	0.0	20.0	-90	-112	-132	-150	4.5	0.3	8.0	-13	-8	2000	9.0	25
JCOS-1100LN	1079	1114	+8.5	0.0	20.0	-88	-110	-130	-150	7.5	0.5	4.5	-15	-10	2000	8.0	25
JTOS-25	12.5	25	+8.0	1.0	11.0	-95	-115	-135	-155	0.03	0.02	1.0-4.0	-26	-13	130	12.0	20
JTOS-50	25	47	+8.5	1.0	15.0	-88	-108	-127	-147	0.06	0.04	2.0-2.6	-19	-12	50	12.0	20
JTOS-75	37.5	75	+8.0	1.0	16.0	-89	-110	-130	-140	0.15	0.11	2.8-4.0	-27	-20	125	12.0	20
JTOS-100	50	100	+8.3	1.0	16.0	-83	-108	-128	-140	0.6	0.2	3.7-4.8	-35	-20	100	12.0	18
JTOS-150	75	150	+9.5	1.0	16.0	-82	-106	-127	-147	0.8	0.3	5.8-6.7	-23	-17	112	12.0	20
JTOS-200	100	200	+10.0	1.0	16.0	-84	-105	-124	-145	1.0	0.2	6-10	-25	-20	110	12.0	20
JTOS-300	150	280	+9.0	1.0	16.0	-82	-102	-122	-142	1.0	0.2	9-14	-28	-20	120	12.0	20
JTOS-400	200	380	+9.0	1.0	16.0	-82	-102	-122	-142	1.4	0.4	10.5-17.1	-25	-20	130	12.0	20
JTOS-535	300	525	+9.5	1.0	16.0	-75	-97	-117	-137	2.0	0.5	10-24	-28	-20	115	12.0	20
JTOS-765	485	765	+8.0	1.0	16.0	-75	-98	-118	-138	2.0	0.5	20-30	-30	-20	100	12.0	20
JTOS-850WW	400	850	+6.0	0.5	18.0	-74	-96	-116	-136	6.0	1.5	15-80	-20	—	185	5.0	20
JTOS-1000W	500	1000	+7.0	1.0	18.0	-73	-94	-114	-134	5.0	1.0	30-40	-26	-20	100	12.0	25

Tuning Sensitivity

Surface Mount

Voltage Controlled Oscillator

JTOS-1000W+

Wide Band 500 to 1000 MHz

Features

- wide frequency range, 500 to 1000 MHz typ.
- 3 dB modulation bandwidth 100 kHz typ.
- octave, linear tuning
- low phase noise, -134 dBc/Hz at 1 MHz offset, typ.
- excellent harmonic suppression, -26 dBc typ.
- aqueous washable

Applications

- test instruments-signal generators
- wideband frequency synthesizers
- agile communications systems
- catv distribution and set-top convertors
- cellular up and down converters
- digital cordless phones



CASE STYLE: BK377
PRICE: \$21.95 ea. QTY (5-49)

+RoHS Compliant

The +Suffix identifies RoHS Compliance. See our web site for RoHS Compliance methodologies and qualifications

Electrical Specifications

FREQUENCY (MHz)		POWER OUTPUT (dBm)	TUNING VOLTAGE (V)		PHASE NOISE (dBc/Hz) SSB at offset frequencies: Typ.				PULLING pk-pk @ 12 dB (MHz)	PUSHING (MHz/V)	TUNING SENSITIVITY (MHz/V)	HARMONICS (dBc)		3 dB MODULATION BANDWIDTH (MHz)	DC OPERATING POWER	
Min.	Max.	Typ.	Min.	Max.	1 kHz	10 kHz	100 kHz	1 MHz	Typ.	Typ.	Typ.	Typ.	Max.	Typ.	Vcc (volts)	Current (mA) Max.
500	1000	+7.0	1.0	18	-73	-94	-114	-134	5.0	1.0	30-40	-26	-20	0.1	12	25

Frequency Range

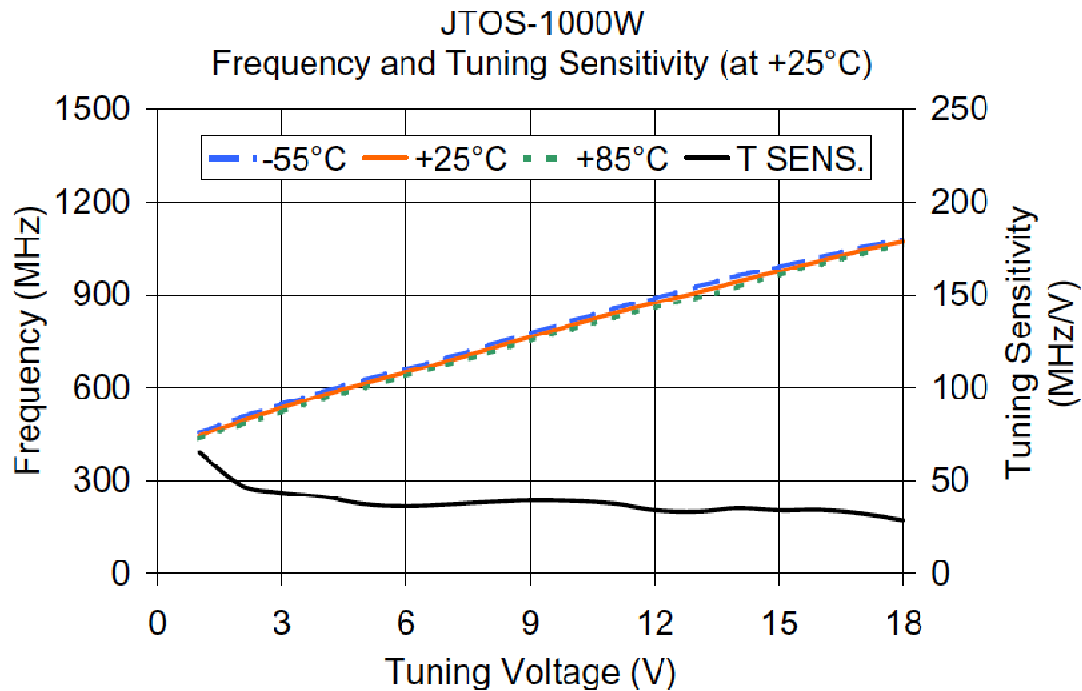

V TUNE	TUNING SENS. (MHz/V)	FREQUENCY (MHz)		
		-55°C	+25°C	+85°C
1.00	65.31	455.40	443.44	433.76
2.00	47.64	503.88	491.08	480.00
3.00	43.38	546.43	534.46	521.76
4.00	41.23	587.53	575.68	562.24
5.00	37.18	624.47	612.87	600.23
6.00	36.00	660.47	648.87	636.80
7.00	36.98	697.54	685.84	673.93
8.00	38.32	736.41	724.17	711.94
9.00	39.19	775.71	763.36	750.82
10.00	38.93	815.33	802.29	789.02
11.00	37.42	854.60	839.71	825.08
12.00	33.97	889.31	873.67	857.98
13.00	33.20	925.48	906.87	889.55
14.00	35.13	960.60	942.00	925.73
15.00	33.97	991.30	975.97	963.00
16.00	34.17	1022.17	1010.14	999.00
17.00	32.21	1052.63	1042.35	1031.78
18.00	28.65	1081.03	1070.99	1060.58

- Change in slope [MHz/V] over tuning voltage range

Tuning Sensitivity

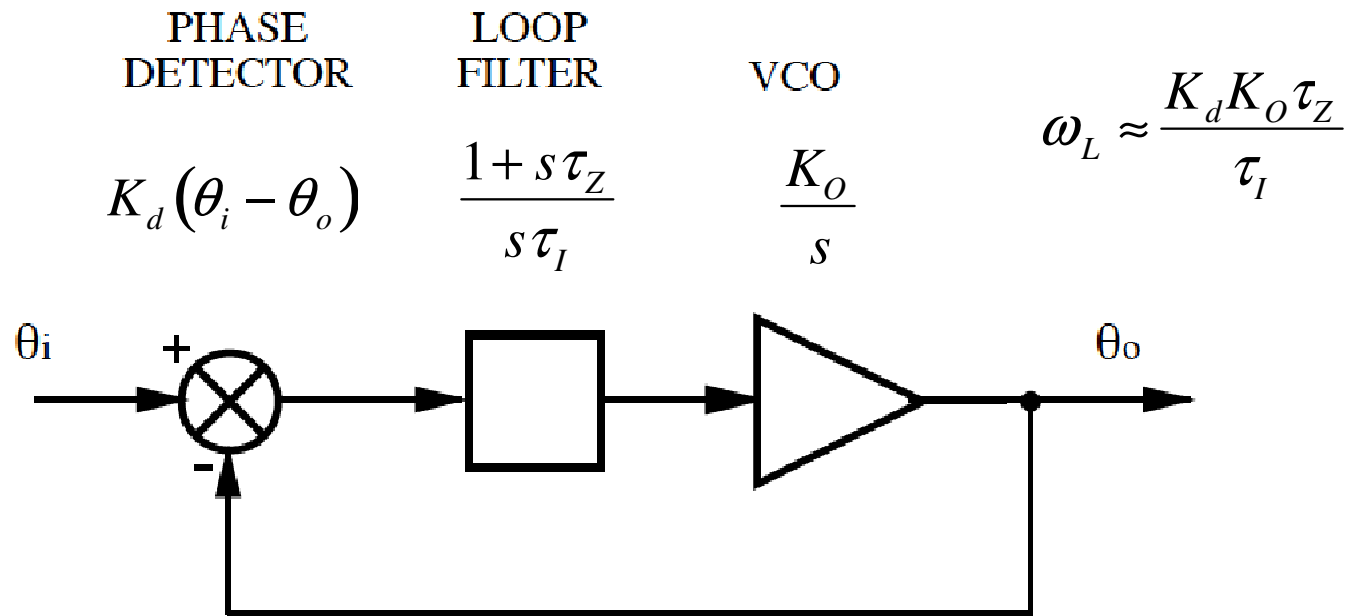
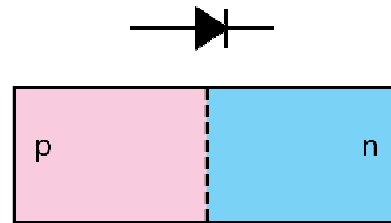

Fig. 3.5. Phaselock loop as a control system.

- Why do you care?
 - PLL: Tuning sensitivity K_O affects control parameters
 - Loop bandwidth ω_L (may not be critical)
 - Stability (critical!)

Varactor Tuning

$$C_j = \frac{C_{j0}}{\left(1 + \frac{V_{TUNE}}{V_{bi}}\right)^m}$$



$$f_{osc} = \frac{1}{2\pi\sqrt{LC}}$$

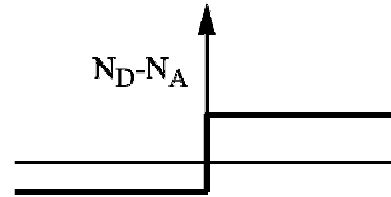

$$f_{osc} \approx \frac{1}{2\pi\sqrt{LC_{j0}}} \left(\frac{V_{TUNE}}{V_{bi}}\right)^{m/2} \quad m = 1/2$$

- **Disadvantages of abrupt junction C-V characteristic ($m=1/2$)**
 - **Smaller tuning range**
 - **Inherently nonlinear $V_{TUNE} - f_{OSC}$ characteristic**

Hyperabrupt Junction Varactor

$$C_j = \frac{C_{j0}}{\left(1 + \frac{V_{TUNE}}{V_{bi}}\right)^m}$$

$$f_{osc} = \frac{1}{2\pi\sqrt{LC}}$$

$$f_{osc} \approx \frac{1}{2\pi\sqrt{LC_{j0}}} \left(\frac{V_{TUNE}}{V_{bi}}\right)^{m/2}$$

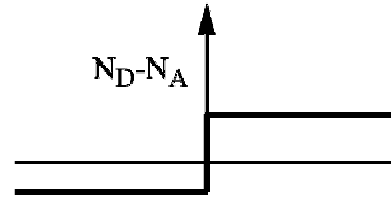
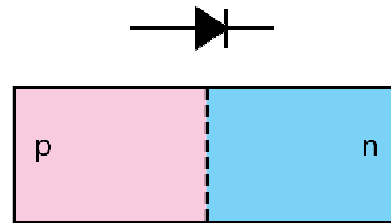

$$m = 1/2$$

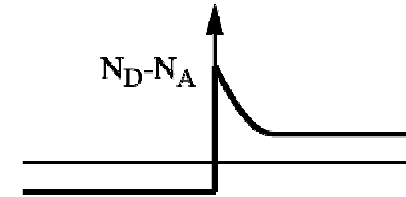
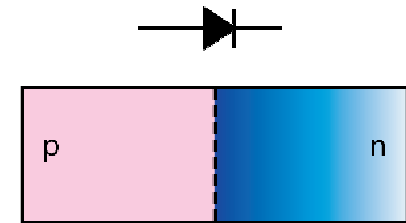

$$m \rightarrow 2$$

- **Hyperabrupt junction C-V characteristic ($m \approx 2$)**
 - + **Larger tuning range; more linear $V_{TUNE} - f_{OSC}$**
 - **Disadvantage: Lower Q in resonator**

Phase Noise

Surface Mount

Voltage Controlled Oscillator

JTOS-1000W+

Wide Band 500 to 1000 MHz

Features

- wide frequency range, 500 to 1000 MHz typ.
- 3 dB modulation bandwidth 100 kHz typ.
- octave, linear tuning
- low phase noise, -134 dBc/Hz at 1 MHz offset, typ.
- excellent harmonic suppression, -26 dBc typ.
- aqueous washable

Applications

- test instruments-signal generators
- wideband frequency synthesizers
- agile communications systems
- catv distribution and set-top convertors
- cellular up and down converters
- digital cordless phones



CASE STYLE: BK377
PRICE: \$21.95 ea. QTY (5-49)

+RoHS Compliant

The +Suffix identifies RoHS Compliance. See our web site for RoHS Compliance methodologies and qualifications

Electrical Specifications

FREQUENCY (MHz)		POWER OUTPUT (dBm)	TUNING VOLTAGE (V)		PHASE NOISE (dBc/Hz) SSB at offset frequencies: Typ.				PULLING pk-pk @ 12 dBc (MHz)	PUSHING (MHz/V)	TUNING SENSITIVITY (MHz/V)	HARMONICS (dBc)		3 dB MODULATION BANDWIDTH (MHz)	DC OPERATING POWER	
Min.	Max.	Typ.	Min.	Max.	1 kHz	10 kHz	100 kHz	1 MHz	Typ.	Typ.	Typ.	Typ.	Max.	Typ.	Vcc (volts)	Current (mA) Max.
500	1000	+7.0	1.0	18	-73	-94	-114	-134	5.0	1.0	30-40	-26	-20	0.1	12	25

Phase Noise

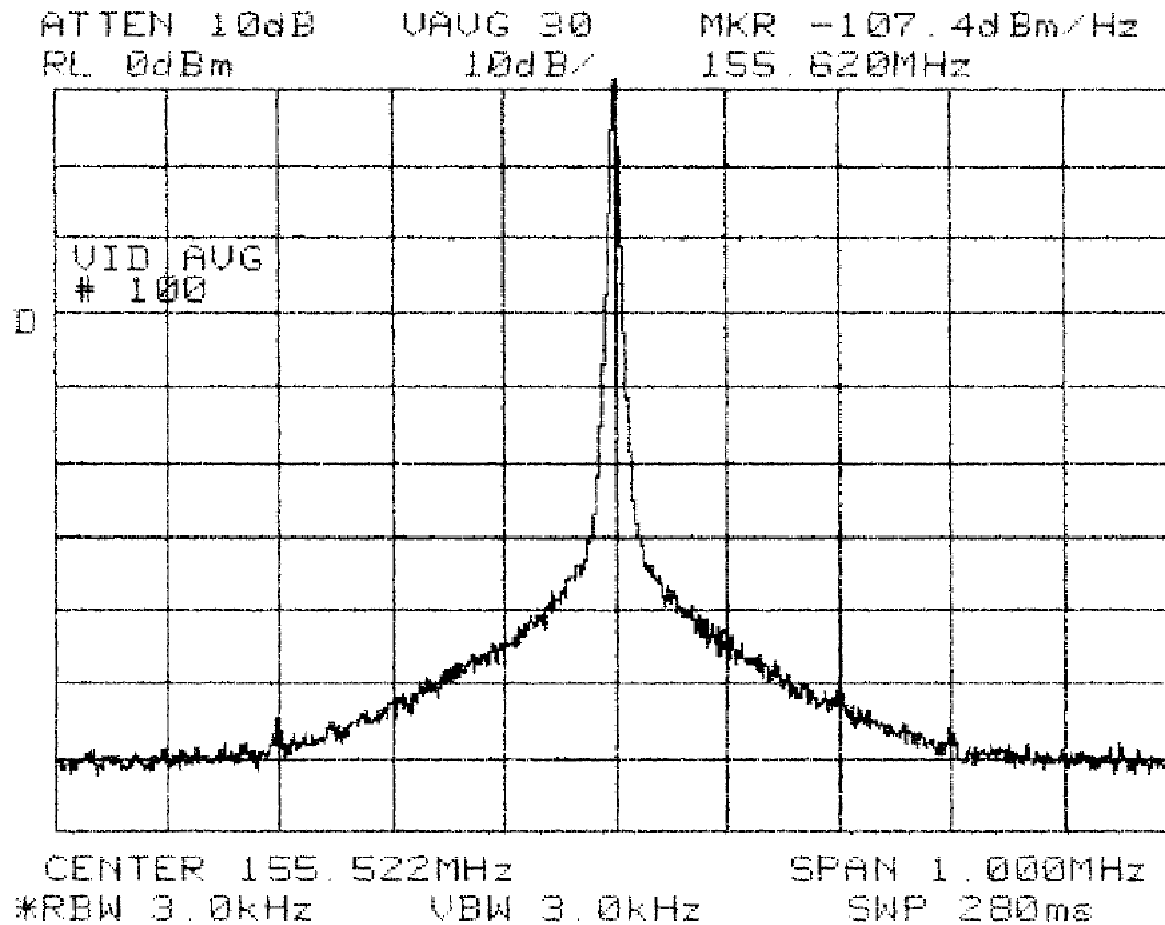

- Power spectrum “close in” to carrier

Phase Noise: RF System

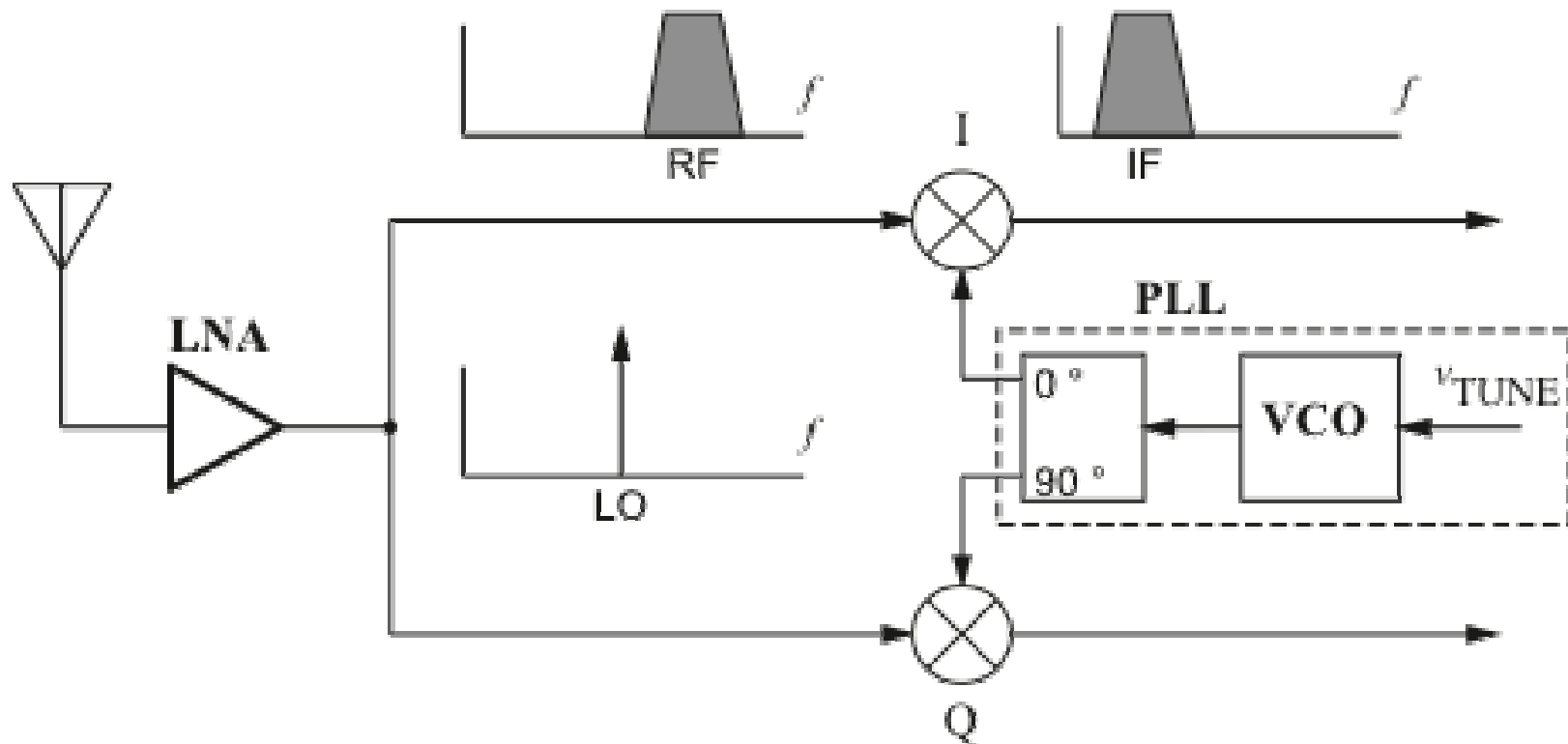

- Mixers convolve LO spectrum with RF
- Phase noise “blurs” IF spectrum

Phase Noise: Digital System

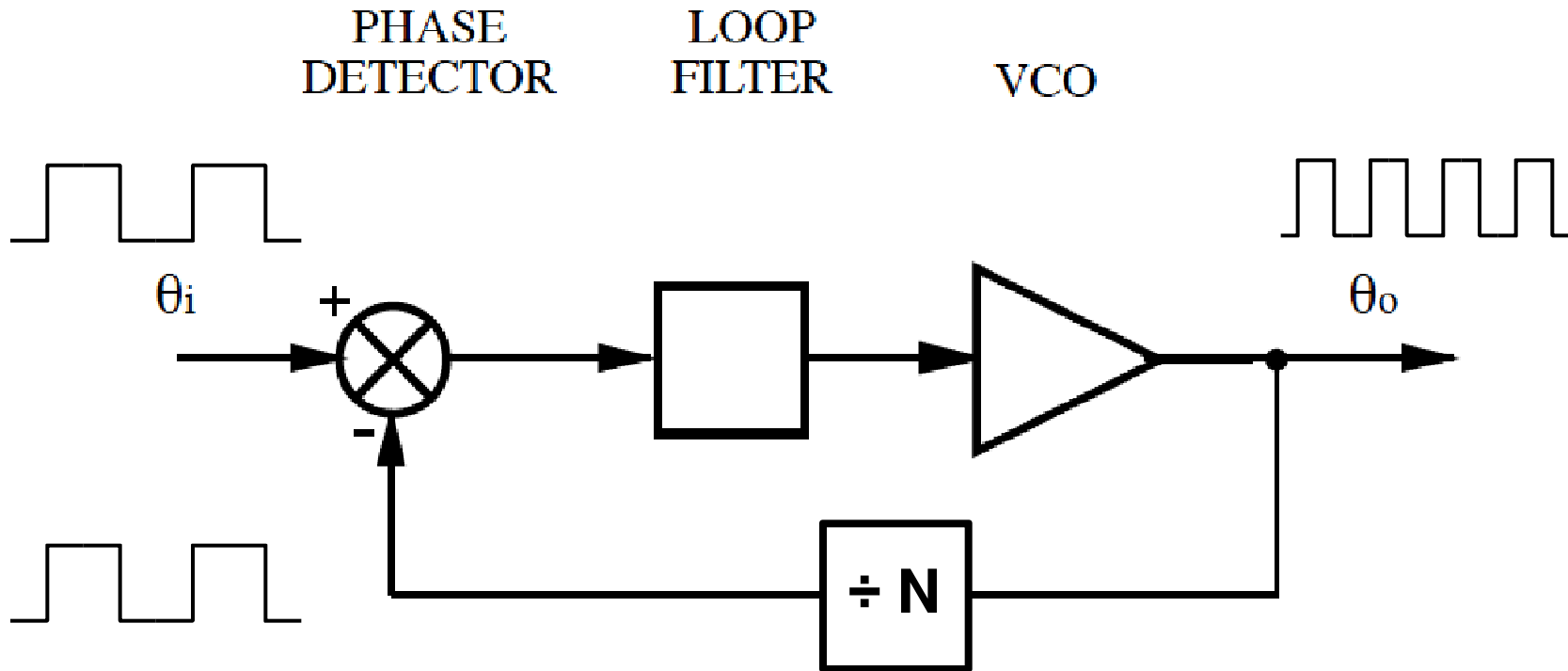

- Time domain jitter on synthesized output clock
- Decreases timing margin for system using clock

Shape of Phase Noise Spectrum

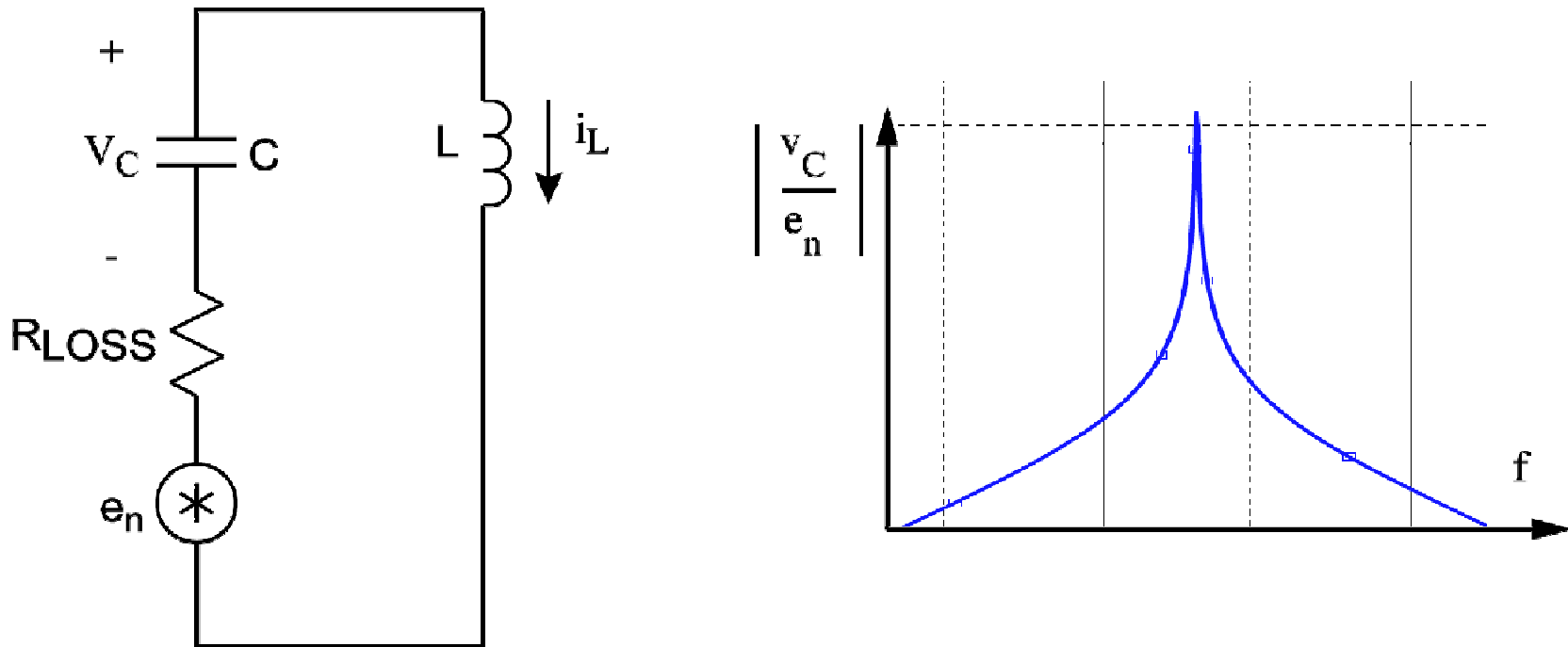

- **LC filters noise into narrow band near fundamental**
- **High Q resonator preferred to minimize noise**

Phase Noise: Intuitive view

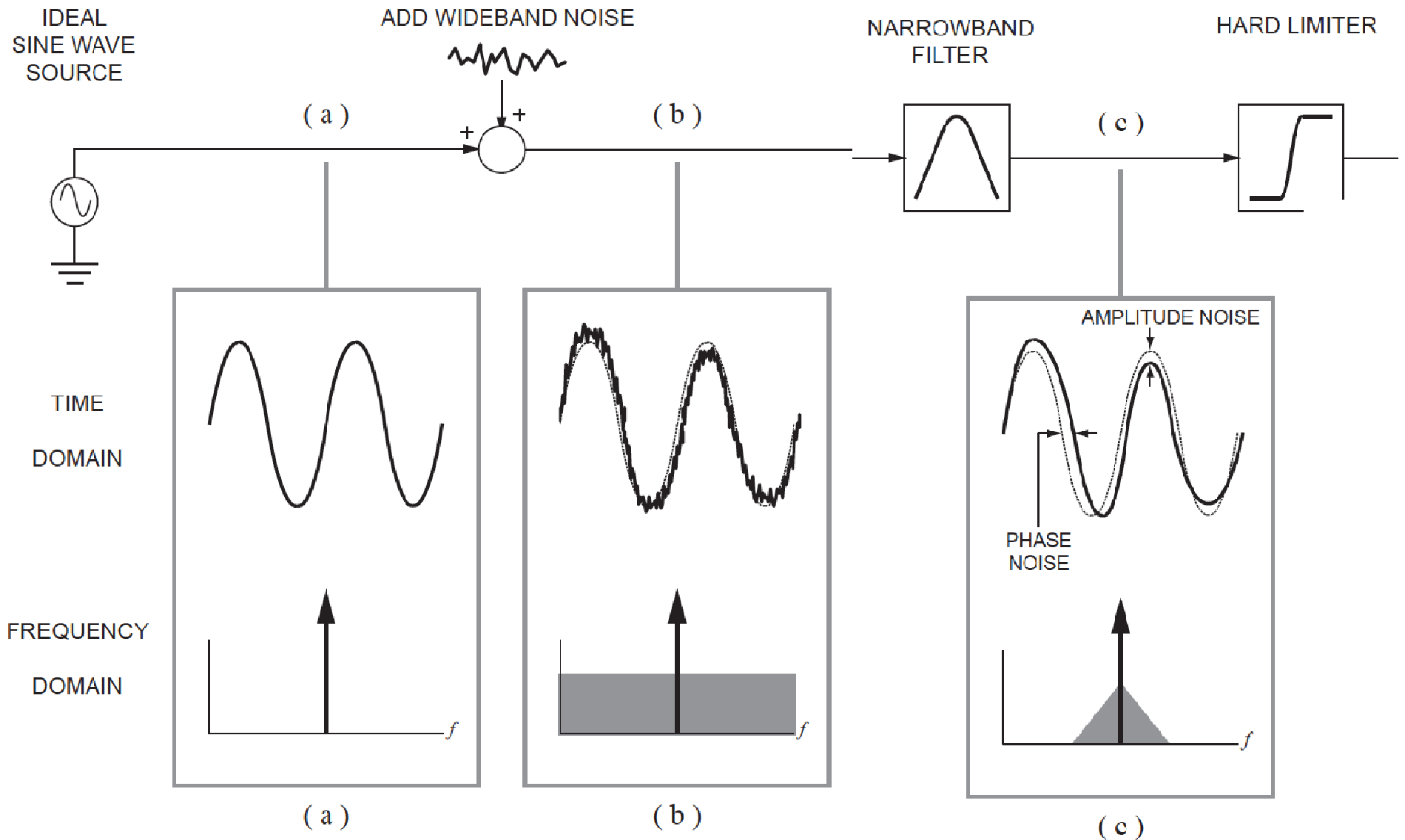

Phase Noise: Intuitive view

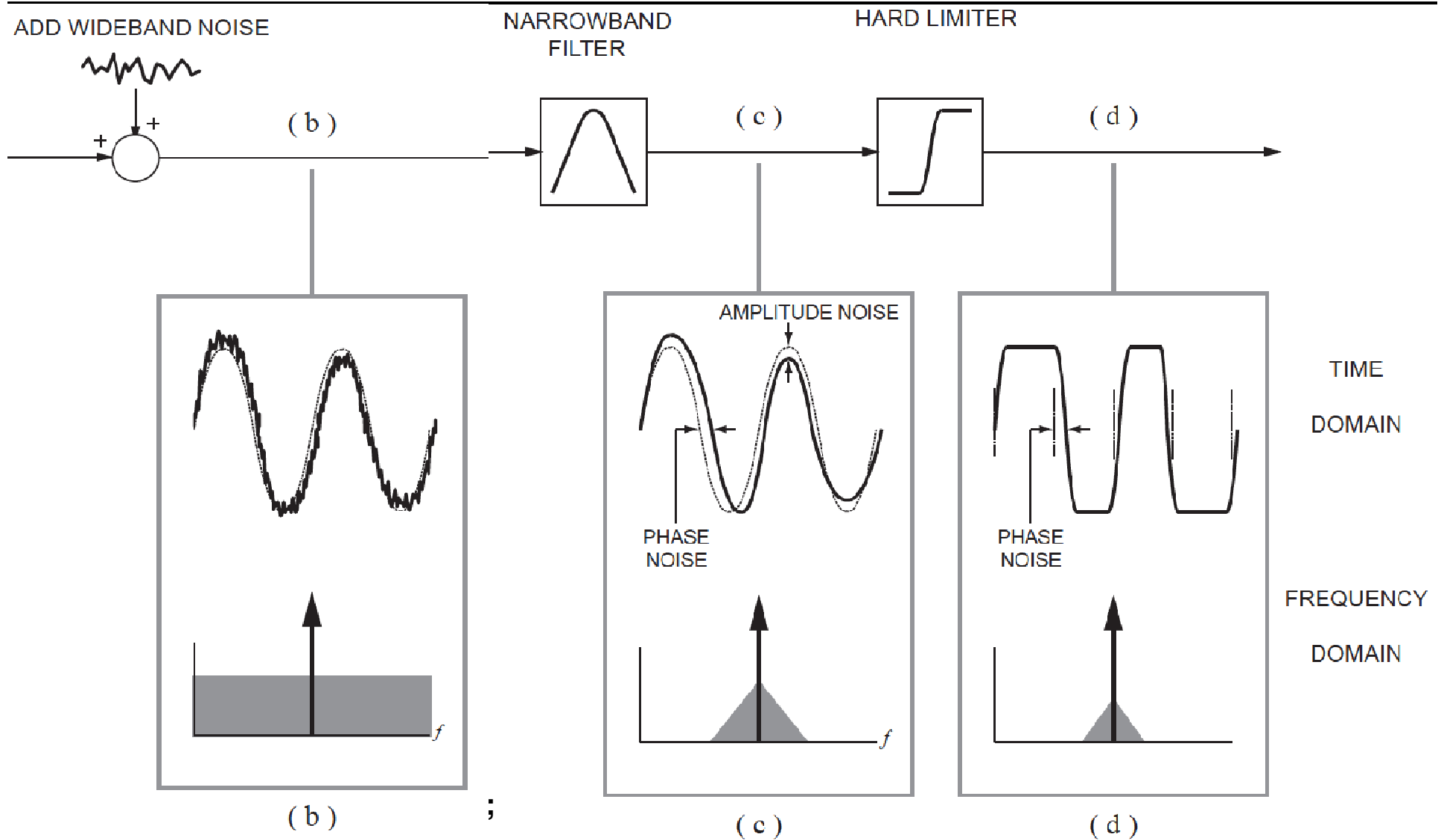

Phase Noise Description

$S_{n1}(f)$ (a) Ideal white noise at VCO input

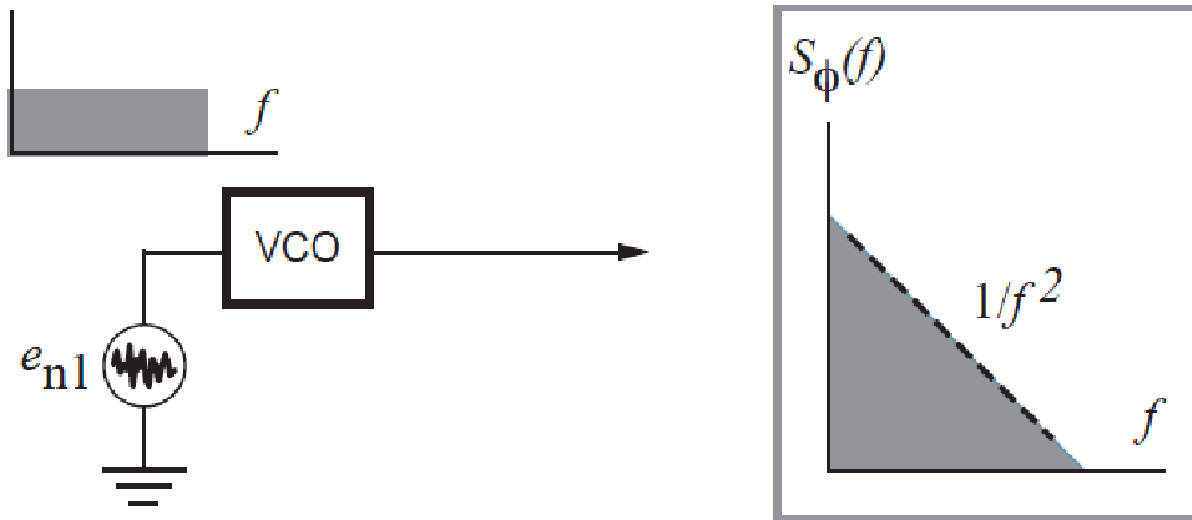

- **Symmetric; look at single sided representation**
- **Normalized to carrier: dBc**
- **At different offset frequencies from carrier**
- **White frequency noise: phase noise with -20dB/decade slope**
- **Other noise processes change slope; 1/f noise gives -30dB/decade**

Phase Noise Specification

Surface Mount

Voltage Controlled Oscillator

PHASE NOISE
(dBc/Hz)
SSB at offset frequencies:
Typ.

1 kHz	10 kHz	100 kHz	1 MHz
-73	-94	-114	-134

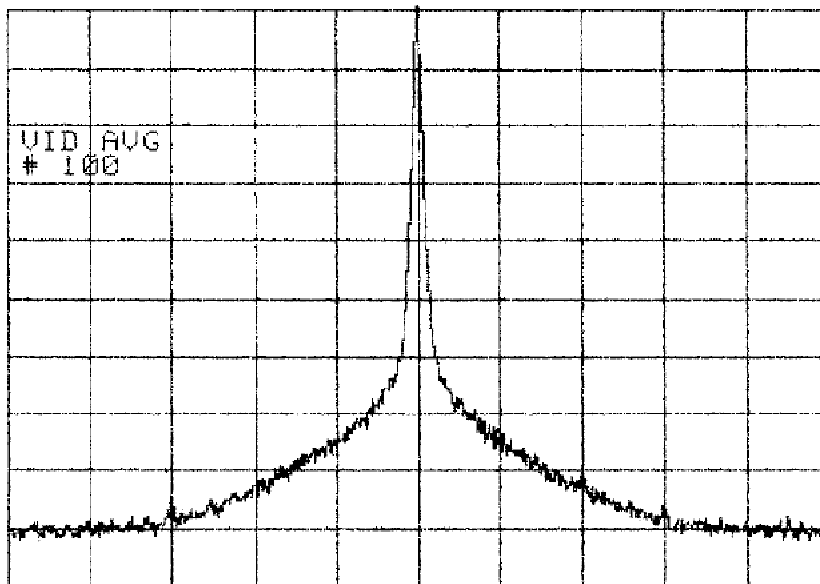

$S_{\phi}(f)$

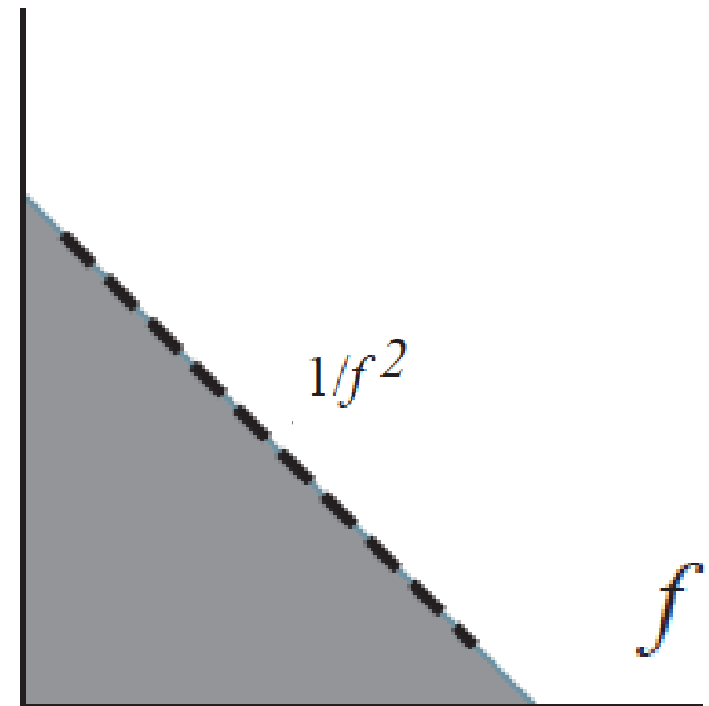

Sources of Phase Noise

White noise in V_{TUNE} signal path

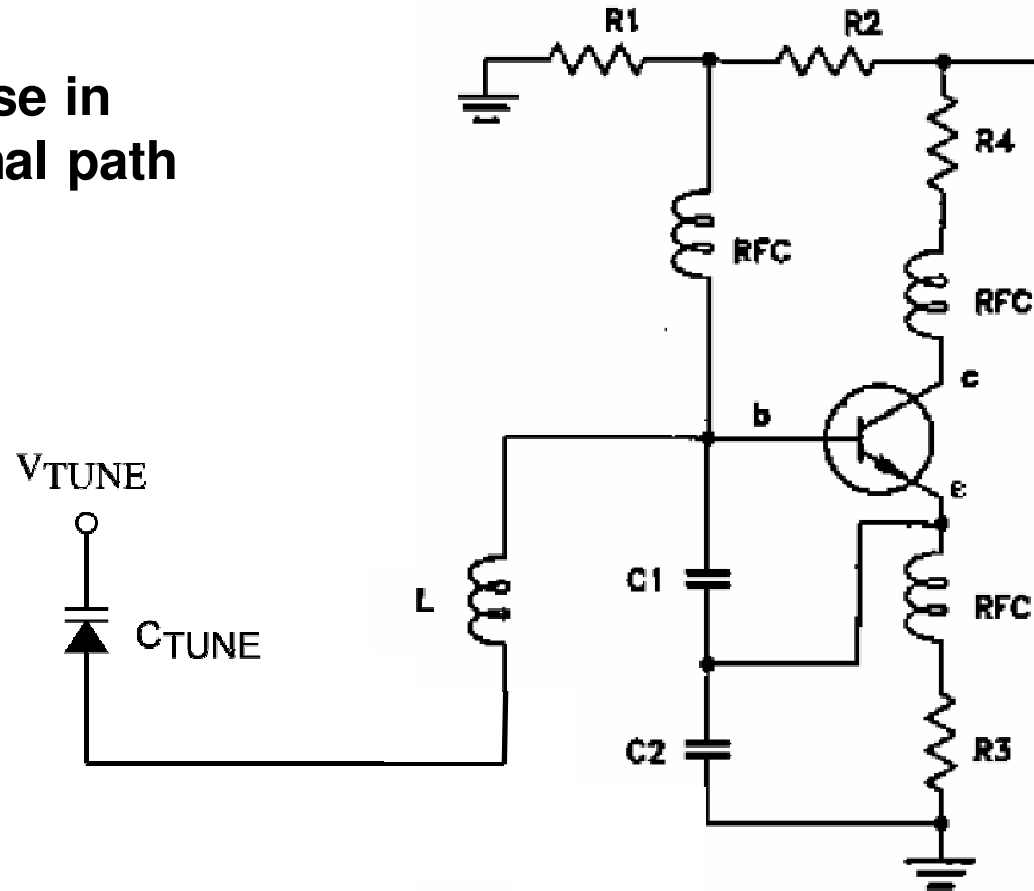

Noise of active devices

Thermal noise: Losses in resonator, series R of varactor

Supply / Load Sensitivity

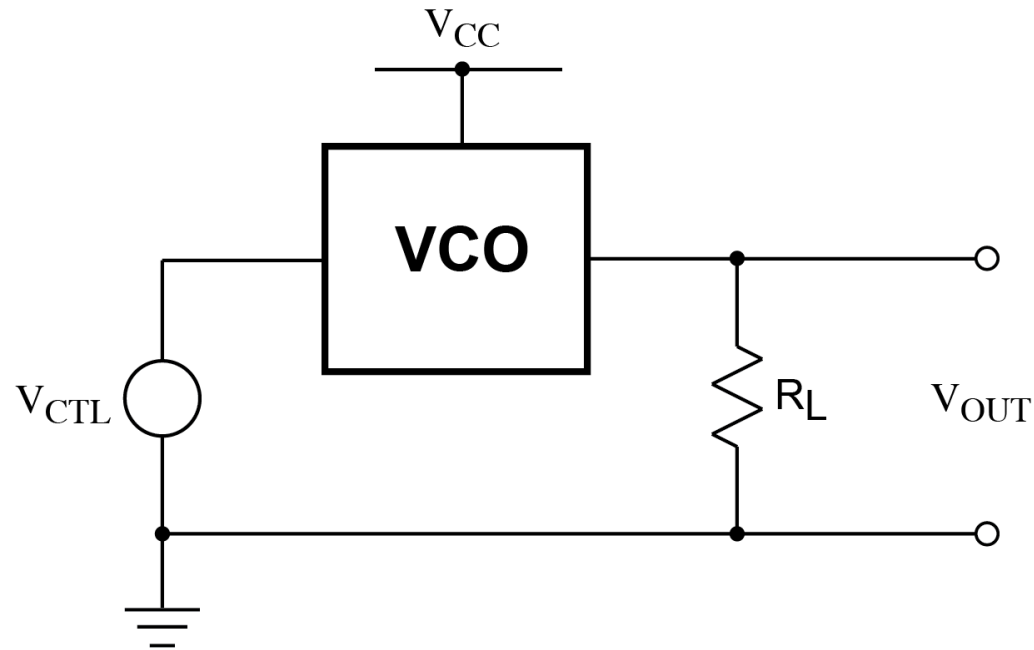

- Ideally tuning voltage is the only way to change output frequency
 - In reality other factors involved
 - Mechanism depends on specifics of circuit
- Power supply dependence: Supply Pushing
- Impedance mismatch at output: Load Pulling

Supply Pushing

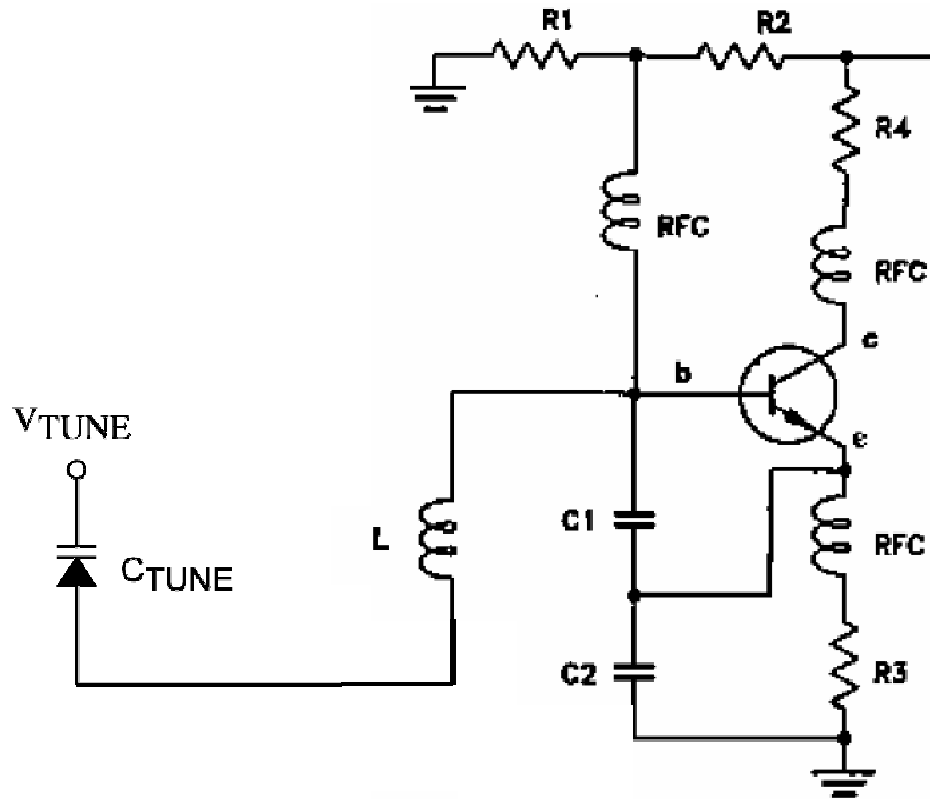

- Change in f_{osc} due to change in supply voltage
- Clapp oscillator: supply affects transistor bias condition, internal signal amplitudes

Load Pulling

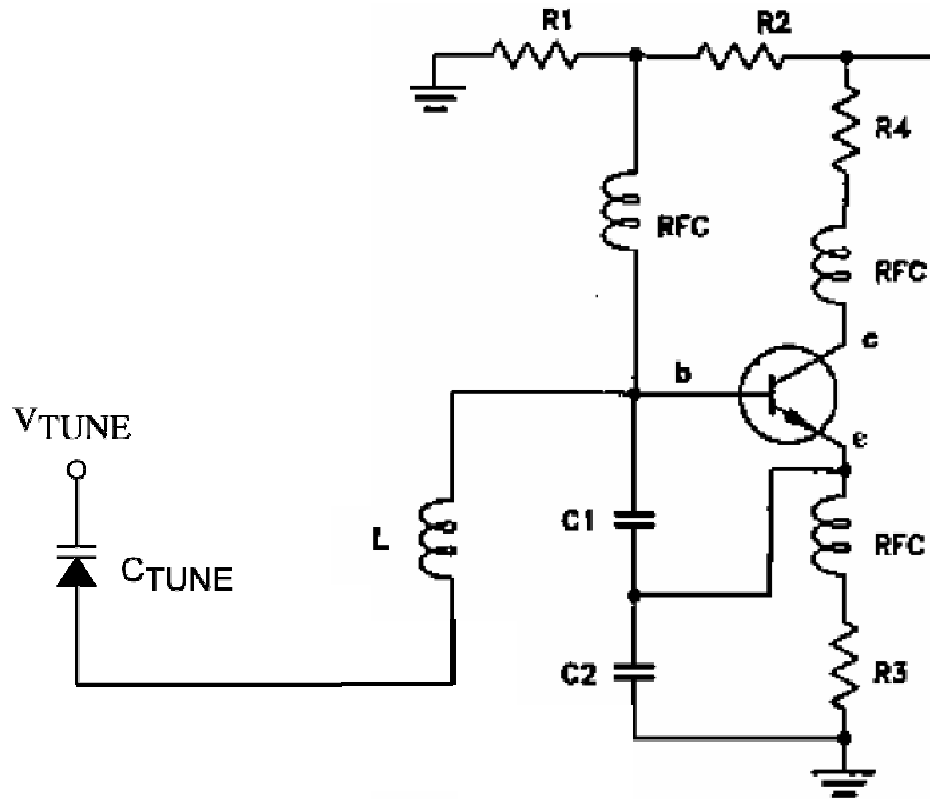

- Change in f_{osc} due to impedance mismatch at output
- Clapp oscillator; reflection couples through transistor parasitic to LC resonator

Overview

- **Functional Block Concept**
- **Oscillator Review**
- **Basic Performance Metrics**
- **Methods of Tuning**
- **Advanced Performance Metrics**
- **Conclusion**

Summary: VCO Fundamentals

- **First order behavior**
 - Tuning voltage V_{TUNE} controls output frequency
 - Specify by min/max range of f_{OSC} , V_{TUNE}
- **Performance limitations**
 - Linearity of tuning characteristic
 - Spectral purity: phase noise, harmonics
 - Supply, load dependence
- **Different VCO architectures trade frequency range, tuning linearity, phase noise performance**

Questions?

Thank you to our presenter John McNeill and our sponsor Mini-Circuits