



# PIQ-1-SMT

## Broadband 0.1 to 40 GHz IQ Modulator

### PRODUCT HIGHLIGHTS

- Broadband frequency range from 0.1 to 40 GHz
- Single ended I and Q inputs [DC to 10 GHz]
- Single supply 4 V @ 250 mA
- Ideal for high-speed analog or digital phase shifting applications

### DESCRIPTION

The PIQ-1-SMT is an integrated broadband IQ vector modulator with single ended LO and RF (AC coupled) as well as single ended baseband I and Q inputs. I and Q ports are 50Ω single-ended. LO and RF ports are 100Ω differential. An on-chip broadband quadrature generator network allows the PIQ-1-SMT to achieve multi-octave frequency coverage. The PIQ-1-SMT operates with a single positive VCC=4V @ 250 mA supply and is supplied in a surface mount package.

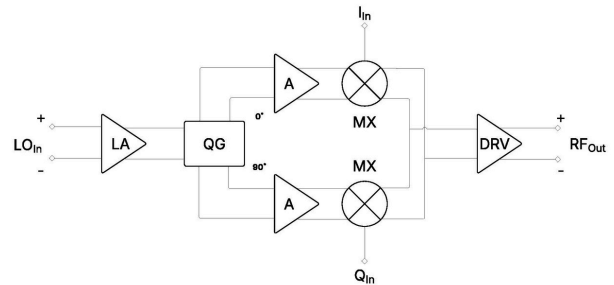

TABLE 1: SPECIFICATIONS

PARAMETER	MIN	TYP	MAX	NOTES
Frequency Range (GHz)	0.1		40	
I and Q Bandwidth (GHz)	DC		10	MAX Voltage: 0 to 3.3 V
Max LO Power (dBm)			+10	
DC Power Dissipation (W)	0.9	1	1.2	VCC= 4V ± 5% @ 250 mA
Package Size				4.0 mm x 4.0 mm x 1.2 mm
Temperature (Operating)	-55°C		+85°C	
Temperature (Storage)	-64°C		+125°C	

## PACKAGE LAYOUT AND PIN DESCRIPTION

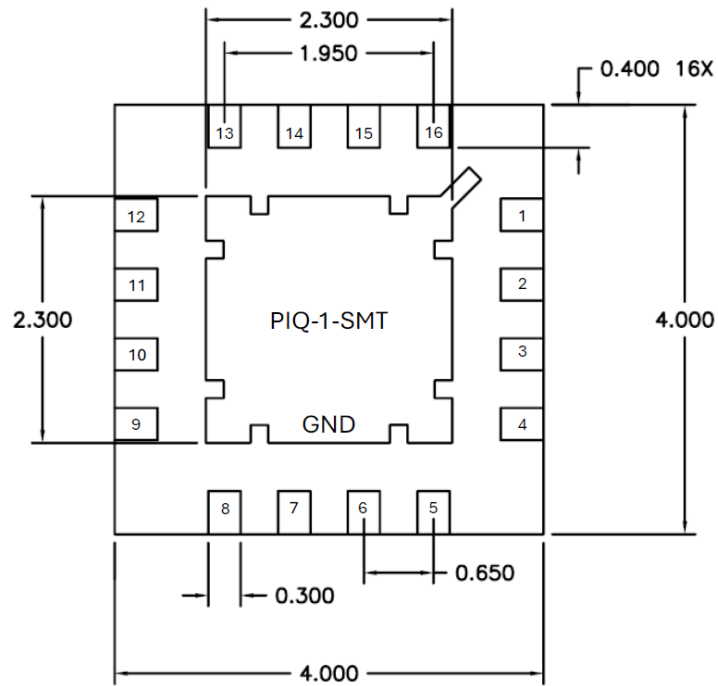

Figure 1: Bottom View

TABLE 2: PIN DESCRIPTION

PIN	DESCRIPTION	PIN	DESCRIPTION
1	GND	9	GND
2	LO+	10	RF+
3	LO-	11	RF-
4	GND	12	GND
5	VCC	13	GND
6	GND	14	I
7	Q	15	GND
8	GND	16	VCC

Applications for the PIQ-1-SMT broadband IQ vector modulator include:

- 5G/6G Communications
- Software Defined Transmission
- Beam Steering
- Wideband SATCOM
- Radar
- Electronic Warfare (EW)
- EW Threat Simulation
- Jamming
- Test & Measurement Front Ends
- Signal Generation
- Spectroscopy
- Quantum Computing

The following data depicts this product’s use as an 8-bit digital phase shifter:

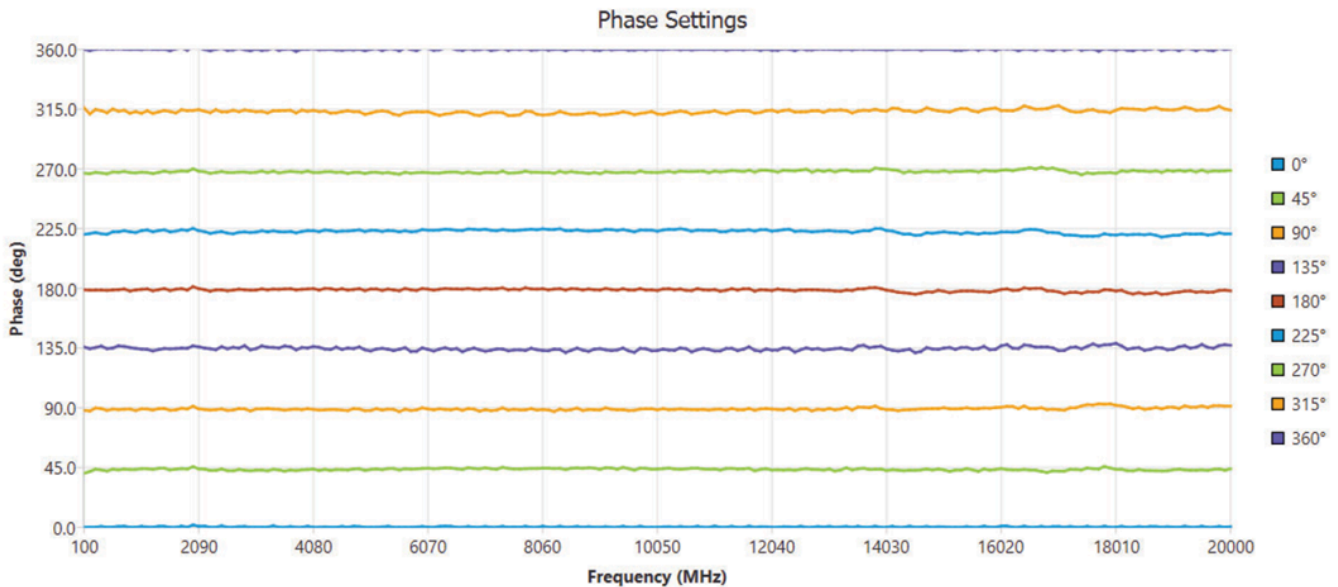

Get a complete list of our components, module portfolio, and available options, and download product features and other technical data at [pmi-rf.com](http://pmi-rf.com)

Or contact us at 1-877-752-6271 or [sales@pmi-rf.com](mailto:sales@pmi-rf.com)

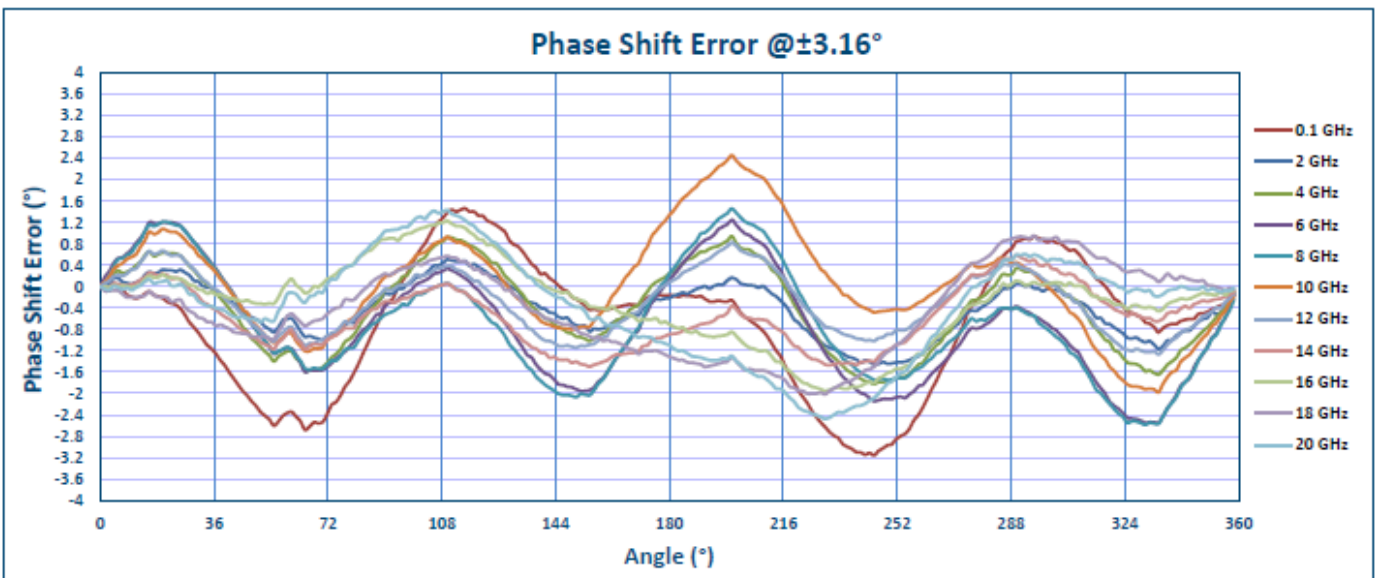
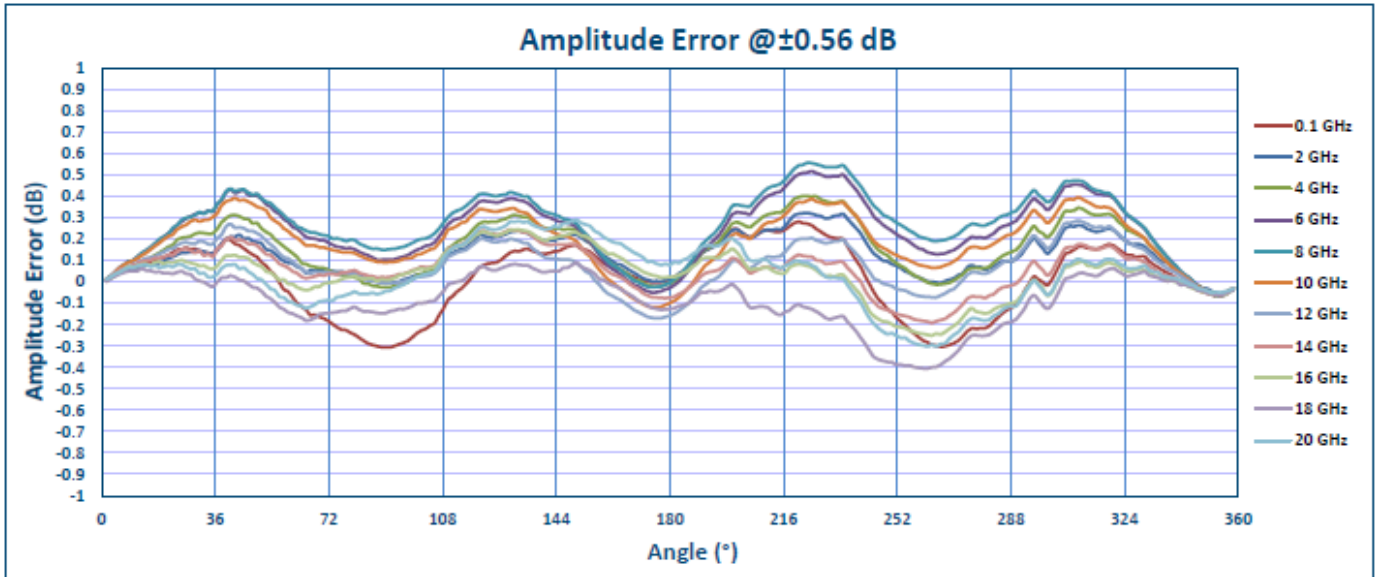

Get a complete list of our components, module portfolio, and available options, and download product features and other technical data at [pmi-rf.com](http://pmi-rf.com)

Or contact us at 1-877-752-6271 or [sales@pmi-rf.com](mailto:sales@pmi-rf.com)

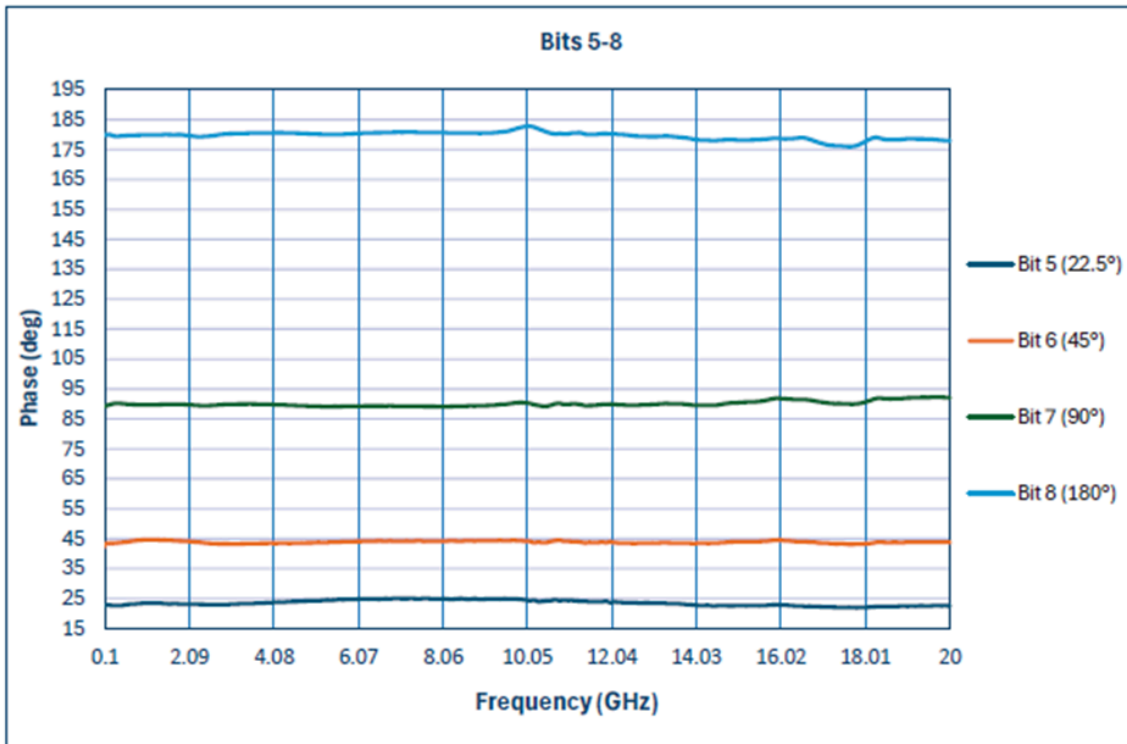
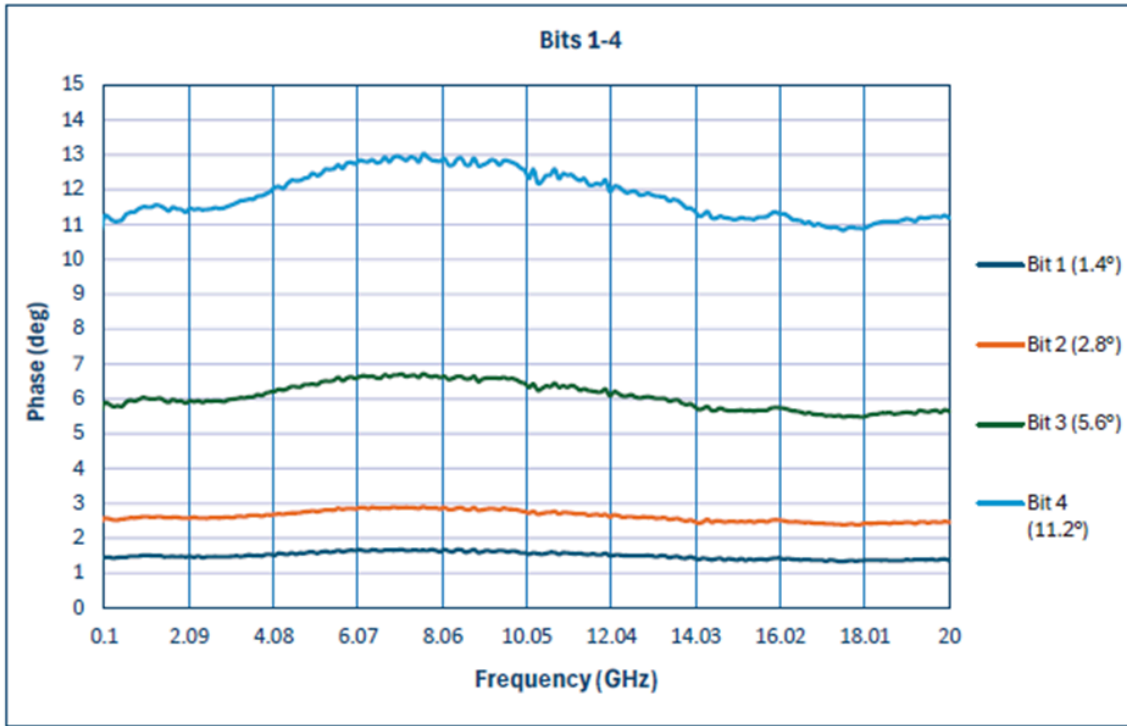

Get a complete list of our components, module portfolio, and available options, and download product features and other technical data at [pmi-rf.com](http://pmi-rf.com)

Or contact us at 1-877-752-6271 or [sales@pmi-rf.com](mailto:sales@pmi-rf.com)

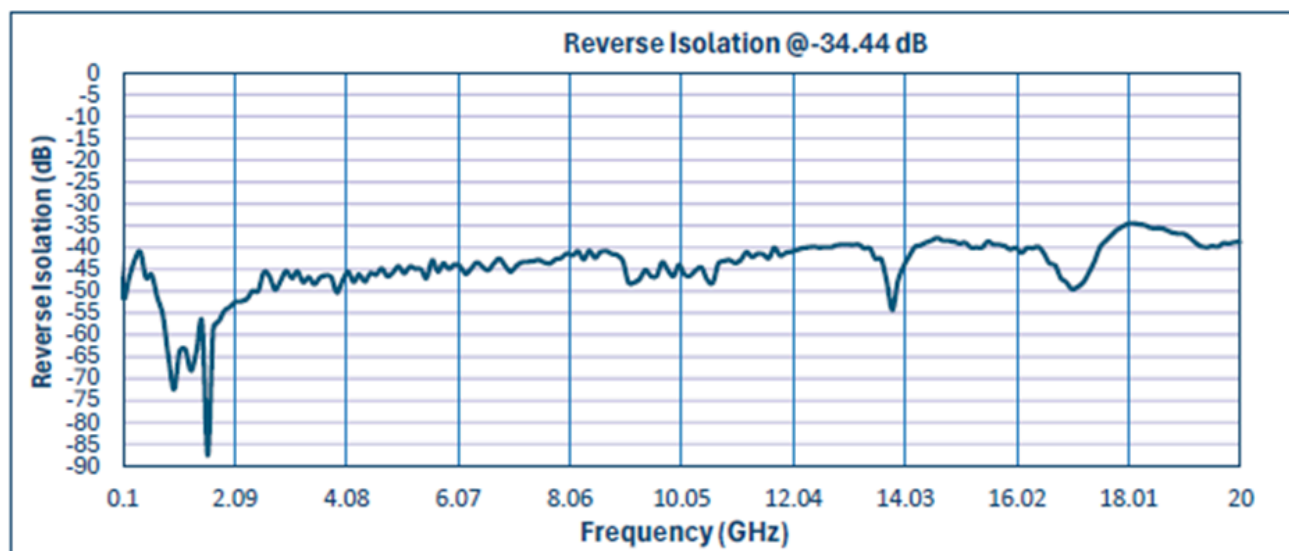
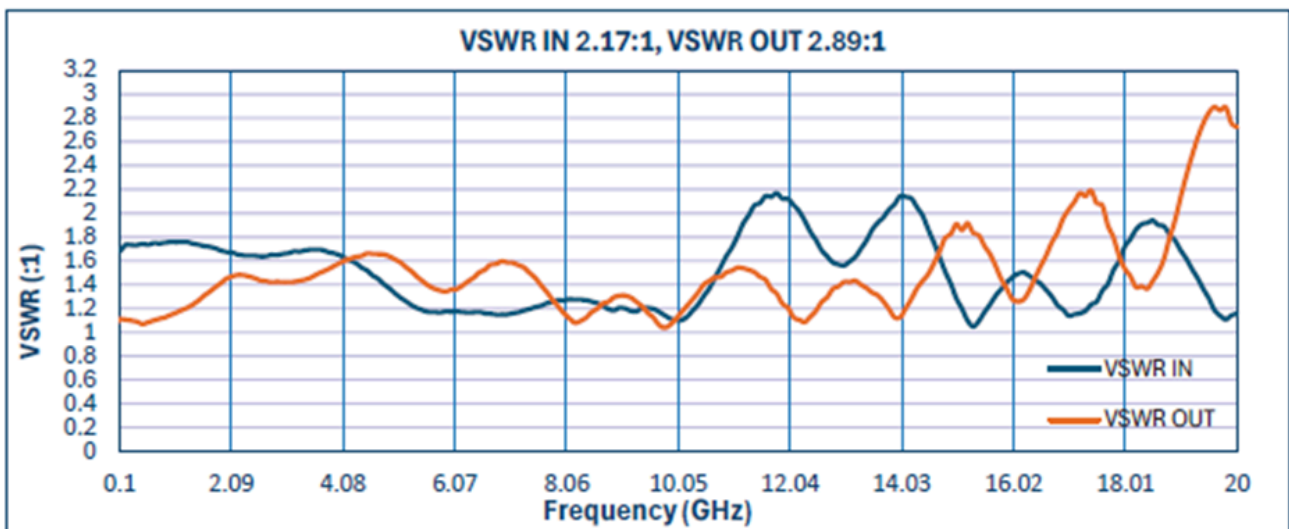
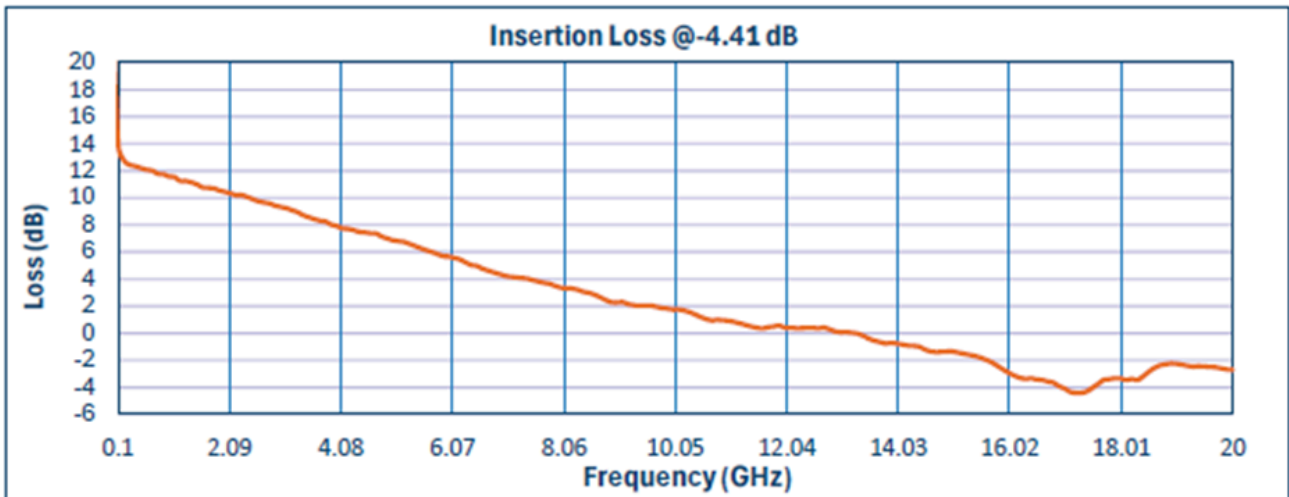

Get a complete list of our components, module portfolio, and available options, and download product features and other technical data at [pmi-rf.com](http://pmi-rf.com)

Or contact us at 1-877-752-6271 or [sales@pmi-rf.com](mailto:sales@pmi-rf.com)

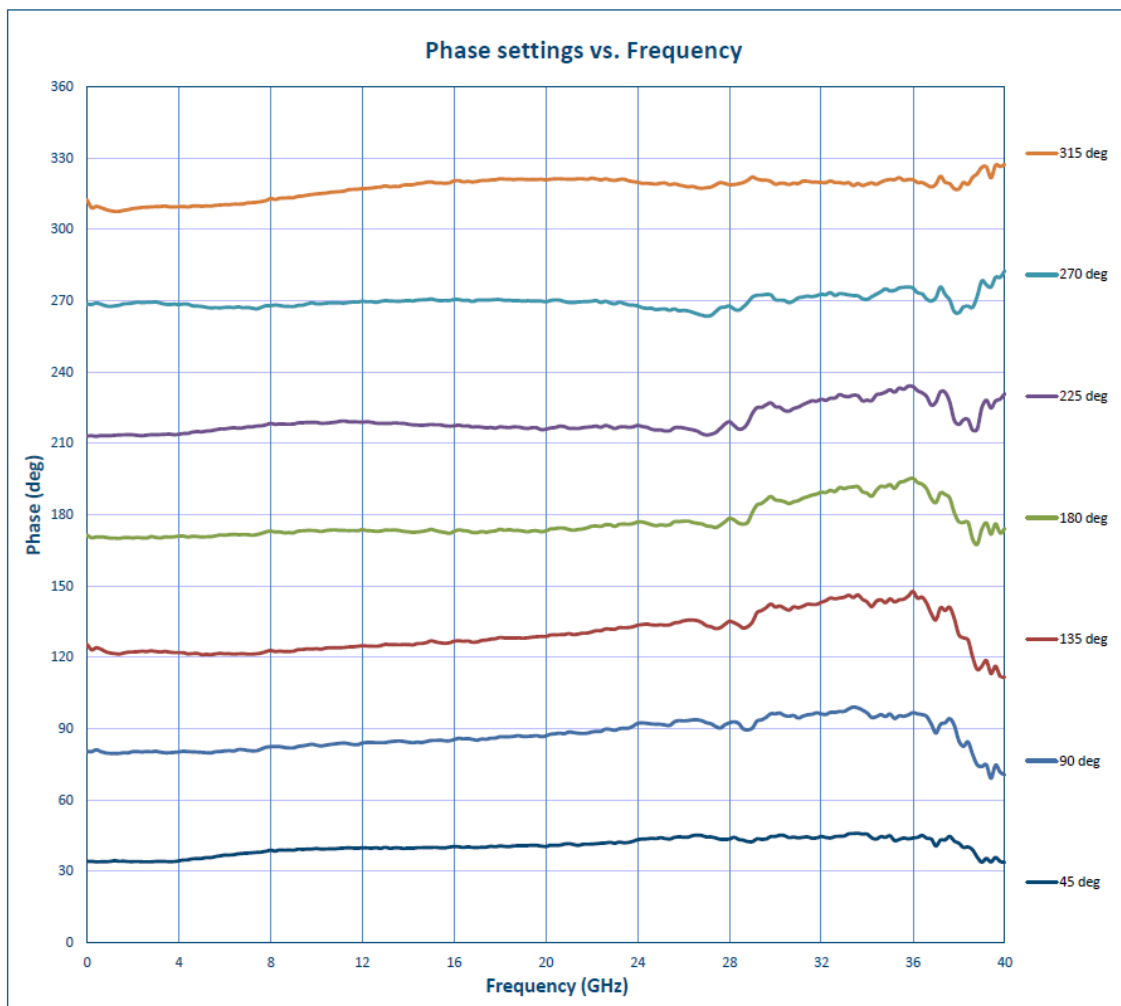
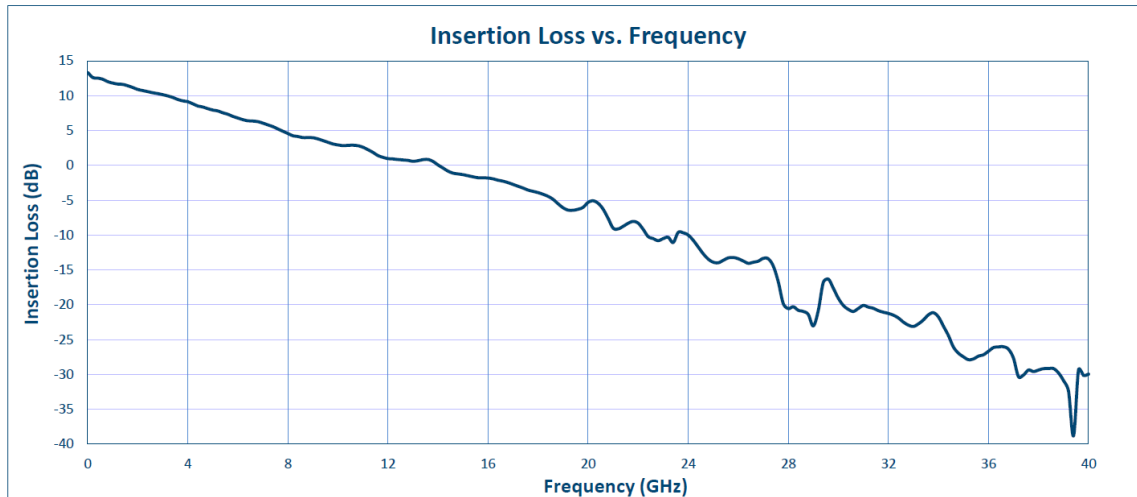

Get a complete list of our components, module portfolio, and available options, and download product features and other technical data at [pmi-rf.com](http://pmi-rf.com)

Or contact us at 1-877-752-6271 or [sales@pmi-rf.com](mailto:sales@pmi-rf.com)

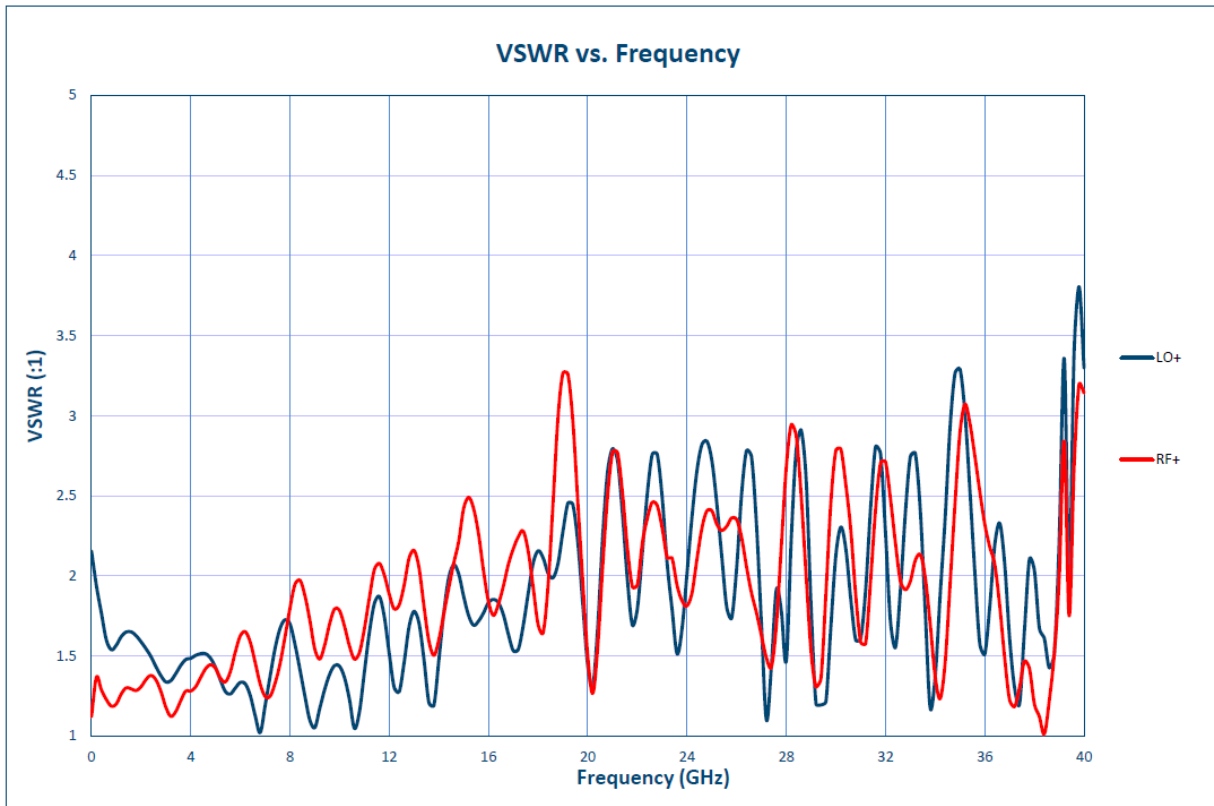

Get a complete list of our components, module portfolio, and available options, and download product features and other technical data at [pmi-rf.com](http://pmi-rf.com)

Or contact us at 1-877-752-6271 or [sales@pmi-rf.com](mailto:sales@pmi-rf.com)

## REFLOW SOLDERING

The following guidelines are intended as a starting point for properly soldering this device to a circuit board. This section is not exhaustive, and we encourage users to develop their own process based on substrate material, solder type, etc. In general, do not allow devices to heat up or cool down too quickly. This could induce thermal stress capable of damaging the product. Based on the package thickness and volume, it is recommended to not exceed the maximum temperatures below.

Maximum Temperature	SnPb Eutectic Process	Pb Free Process
		235°C

**Table 1: Classification Temperatures per IPC/JEDEC J-STD-020E**

Below is a standard example of a reflow process from IPC/JEDEC J-STD-020E. We recommend referring to this example, IPC-7530, and your solder manufacturers recommendations to refine this process. Ultimately, a process that yields effective solder joints and does not damage devices is the goal and can vary based on several factors.

PROFILE FEATURE	SN-PB EUTECTIC ASSEMBLY	PB-FREE ASSEMBLY
Preheat/Soak Temperature Min [ $T_{smin}$ ] Temperature Max [ $T_{smax}$ ] Time [ $t_s$ ] from [ $T_{smin}$ to $T_{smax}$ ]	100°C 150°C 60-120 seconds	150°C 200°C 60-120 second
Ramp-up rate [ $T_L$ to $T_p$ ]	3°C / second max.	3°C / second max.
Liquidous temperature [ $T_L$ ] Time [ $t_L$ ] maintained above $T_L$	183°C 60-150 seconds	217°C 60-150 seconds
Peak package body temperature [ $T_p$ ]	For users $T_p$ must not exceed the Classification temp in Table 4-1. For suppliers $T_p$ must equal or exceed the Classification temp in Table 4-1.	For users $T_p$ must not exceed the Classification temp in Table 4-2. For suppliers $T_p$ must equal or exceed the Classification temp in Table 4-2.
Time [ $t_p$ ] within 5°C of the specified classification temperature [ $T_C$ ]	20* seconds	30* seconds
Ramp-down rate [ $T_p$ to $T_L$ ]	6°C / second max.	6°C / second max.
Time 25°C to peak temperature	6 minutes max.	8 minutes max.

\*Tolerance for peak profile temperature [  $T_p$  ] is defined as a supplier minimum and a user maximum.

**Table 2: Classification Profiles per IPC/JEDEC J-STD-020E**

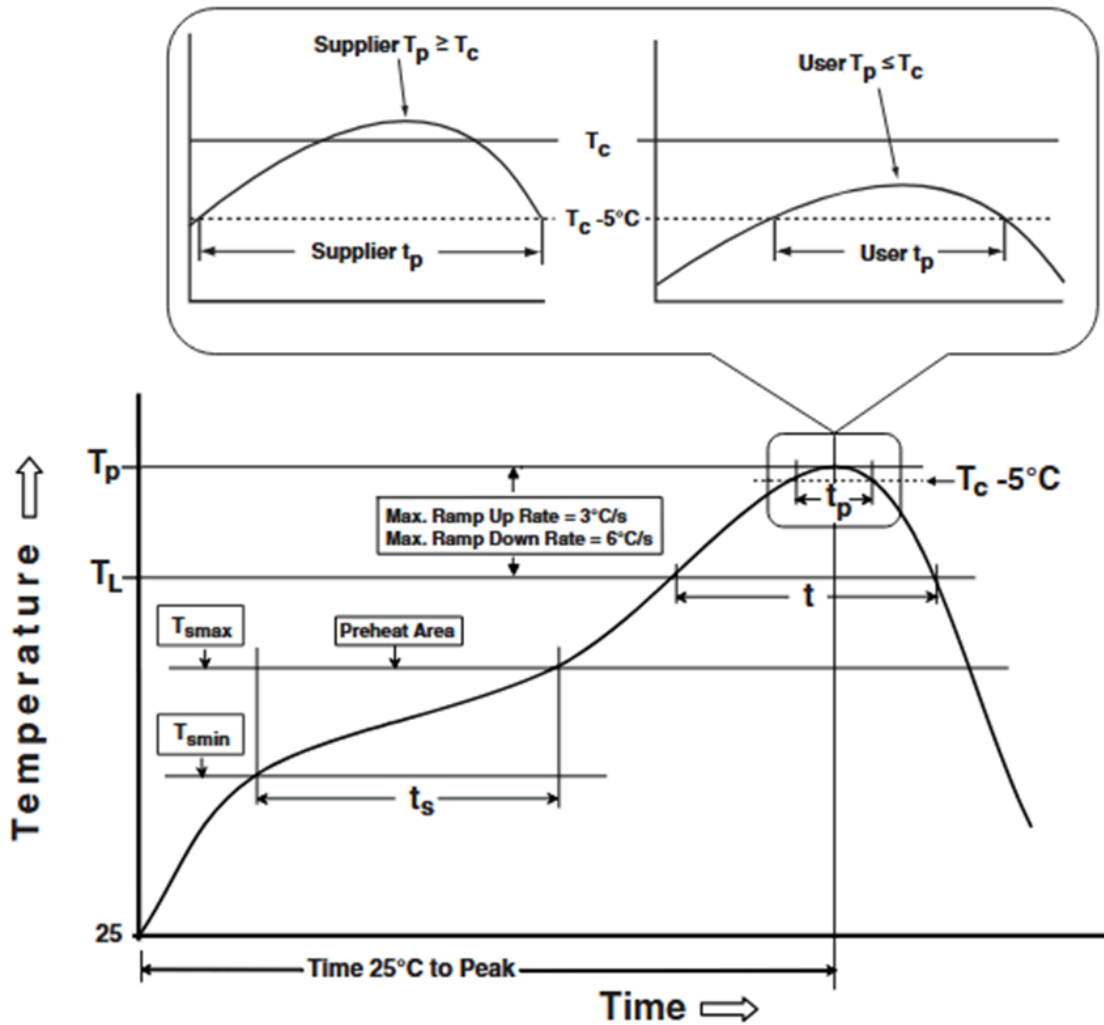

Figure 1: Classification Profile [not to scale] per IPC/JEDEC J-STD-020E