

Magnetron Transmitter - VPX3469

Features:

- 300 kW peak power RF output
- Air cooled
- Built in diagnostics and BIT for local or remote troubleshooting
- Compact design for remote operation

Benefits:

- CPI BMD magnetrons and modulators ensure compatible performance
- Operates in all orientations and during vibration

The VPX3469 Magnetron Transmitter is developed as a fully integrated magnetron system for use as a high power source of RF power for outdoor-mounted radar applications. This microwave transmitter uses the CPI coaxial Magnetron as its RF output device. The enclosure is made for use inside of an antenna pedestal or similar environments. CPI is able to furnish a compact, user-friendly, microwave power source that allows for the antenna environment.

The transmitter cabinet contains the high voltage power supply, solid-state switch, and the high voltage tank assembly which includes the pulse transformer, energy storage high voltage capacitor, and filament power supply.

The high voltage power supply (HVPS) is contained inside the enclosure. It is completely self-protected with over current and input under/over voltage circuits. The high voltage power supply converts input AC into DC then switches it utilizing a short-circuit proof series resonant inverter. The filament power supply needed to operate the magnetrons is contained in this unit. All external interface and control is done in this supply.

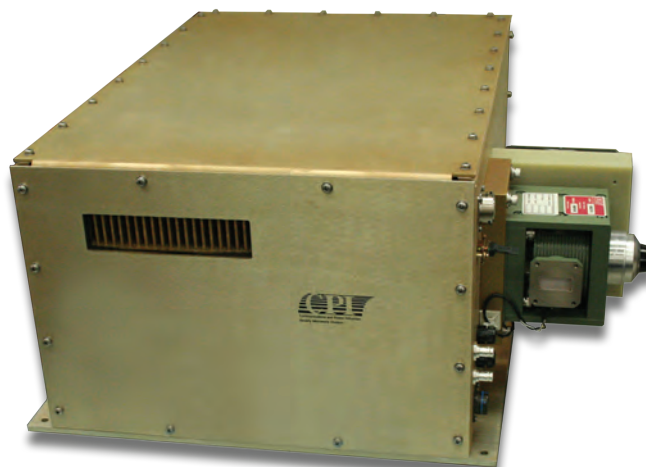

Cathode pulsing is done by a solid state array of IGBT switch boards that is driven by the control interface board in the high voltage power supply. This switch inherently limits current and pulse by design, no external circuitry is required for these functions. The IGBT switch is a current controlled switch, set by a bias voltage from the high voltage power supply control interface board. The voltage across the switch will automatically change as the voltage across the magnetron changes due to frequency and temperature changes. Replacing a magnetron only requires an adjustment of the drive voltage. This switch will inherently limit arc current in the event of a magnetron high voltage arc. The limit is less than twice the normal operating current in the event of a complete short circuit. The switch assembly is conduction cooled to the heat exchanger.

All high voltage is contained in a sealed tank. The pulse transformer that steps up the high voltage power supply output to the voltage that the magnetron requires; the storage capacitor bank to supply the energy during the pulse; and the magnetron filament connections are all contained in this tank. This tank is sealed so that it can function in any orientation and so that it is not affected by normal acceleration levels. The magnetrons are mounted on the side of the enclosure for easy access. An external fan is required to cool the magnetrons.



Magnetron Transmitter - VPX3469

Cooling

Cooling is accomplished by fans internal to the enclosure. The air flows through a plenum and heat exchanger to which all of the heat generating components are connected. The electronics and voltage carrying devices are not subject to outside air and therefore protected from the environmental conditions.

Instrumentation and Control

The magnetron transmitter has an Ethernet connector that accepts control inputs and provides status, fault and alarm conditions, and metered parameter information. The table on page 3 defines the specific control functions, monitored test points, transmitter operating status, fault and alarm conditions, and metered voltages, currents, and operating times.

CPI can provide a GUI or the software protocol that allows for operation remotely through the Ethernet connection. The remote interface utilizes an Ethernet IP address with CPI standard protocol and command set. Analog test points are available for diagnostic and performance assessment on the side panel. These test points are buffered to allow the use of standard test equipment such as oscilloscopes.

Pulsed operation and timing are derived from an externally supplied modulator gate signal. This gate will determine the duration of the output RF and pulse repetition frequency (PRF). Internal monitoring circuits will ensure that the acceptable pulse width, PRF, and duty cycle limits of the transmitter are not exceeded. This modulator gate signal is not part of the Ethernet interface and must be supplied separately via a dedicated low impedance driver.

Specification

Specification	Description	Comments
Modulator type	Solid state	IGBT switch modulator current controlled
Frequency	Dependent on magnetron	9.4 – 9.6 GHz per VMX3116
RF Output Power	Dependent on magnetron	300 kW per VMX3116
RF Duty Cycle	Up to 0.001	Depends on the magnetron selected
Pulse Width	Adjustable 0.4 µs to 4 µs	The pulse width is continuously variable based on input gate.
PRF	Maximum: 2 kHz	Must maintain 0.001 duty limits set by magnetron
RF Droop within pulse	0.5 dB max. at max PW	
RF Rise time	50 ns (typical)	
RF Fall time	250 ns (typical)	
Operating Temperature	–40°C to +60°C ambient	Forced air with integral fans
Cooling	Air cooled	Other input voltages are available as options.
Input voltage	208 vac 3 phase, 50/60 Hz, ±5%	(0.85 power factor minimum)
Dimensions	23 x 11 x 18 inches	(depth x height x width)
Weight	150 pounds (approx.)	Depends on the magnetron selected

The values listed above represent specified limits for the product and are subject to change. The data should be used for basic information only. Formal, controlled specifications may be obtained from CPI for use in equipment design.

Magnetron Transmitter - VPX3469

Equipment Protection - Fault Protection

Monitor and shut off triggers for:

- Peak and average cathode current
- Filament power supply regulation and current
- Excessive duty cycle from gate signal
- High voltage under voltage and over current
- Low voltage power supply under voltage
- Excessive temperature for power supply and magnetrons
- External safety interlock

Control Functions

- Transmit/standby (RF On/Off)
- Fault reset

Front Panel Monitoring

- Magnetron pulse current (0.1V/A)
- Trigger sample

Fault Display

- Fault sum
- Interlocks open (external or cover)
- Magnetron average over current
- Magnetron peak over current
- High voltage low
- High voltage current high
- Filament voltage
- Filament current
- Over temperature
- Low voltage power supply
- Drive power supply
- Duty cycle high
- Fault log

Display Monitoring

- Power on
- Heater time delay (HTD)
- Standby
- Transmit (RF On)
- Local/remote
- Beam elapsed hour meter
- Heater elapsed hour meter
- Magnetron average current
- High voltage
- High voltage power supply current
- Filament voltage
- Filament current

The values listed above represent specified limits for the product and are subject to change. The data should be used for basic information only. Formal, controlled specifications may be obtained from CPI for use in equipment design.

Magnetron Transmitter - VPX3469

Control Signals	Description	Comments
Control Inputs	Input Gate	+5 V into 50 ohms, variable width
Ethernet	Radiate Reset	Available remotely Available remotely
Status Outputs	Low voltage power supply fault High voltage power supply fault Filament power supply fault Magnetron over current Over duty Over-temp. Interlock	All available remotely Low voltage power supply < 80% nominal High voltage power supply < 80% nominal Out of regulation Avg. current > 50 mA, peak current > 50 A Duty over 0.001 Excess temperature Open interlock
Meter Outputs	Pulse avg. current High voltage power supply voltage Mod. average current Filament voltage Filament current Filament hours Radiate hours Internal temperature	All available remotely
Adjustment Controls	Peak current adjust	All available remotely

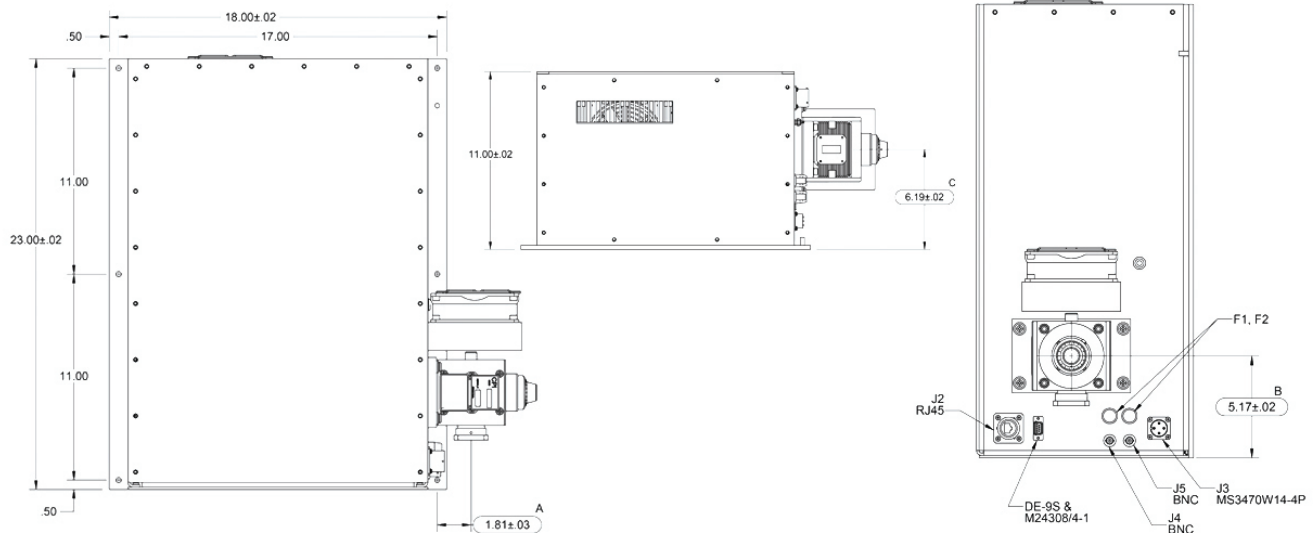

The values listed above represent specified limits for the product and are subject to change. The data should be used for basic information only. Formal, controlled specifications may be obtained from CPI for use in equipment design.