

AM35 – EMI Filter Bank

Power and Control Line



Description

AM35 provides 6 filters in a tiny 1.5mm x 3mm package for filtering power and control lines that is necessary for spurious signal suppression for amplifiers, step attenuators, tunable filters, and switches. The device offers simplicity and space savings compared to the traditional discrete design approaches. The AM35 provides one power line filter and 5 control line filters spaced at 0.5mm pitch to mate perfectly with your standard QFN devices.

Features

- One Power Line Filter
- Five Control Line Filters
- 100 MHz Corner Frequency – Control
- 300 MHz Corner Frequency – Power
- 50 dB Rejection
- 16 V Voltage Handling Capability
- 4mA/150mA Control/Power Capability
- 7.2ns Control Line RC Constant
- 1.5mm x 3mm DFN
- 0.5 mm Lead Pitch
- -40C to +85C Operation
- Symmetric Filtering

Functional Diagram

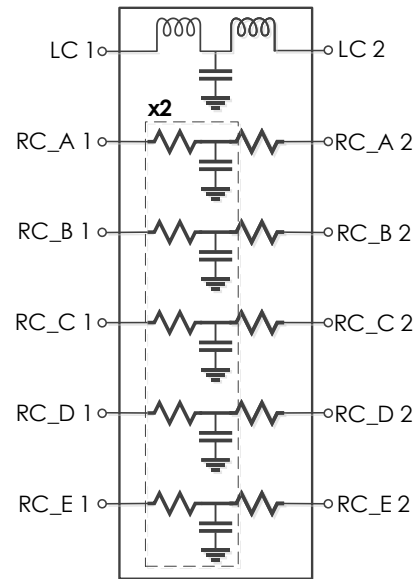

Characteristic Performance

(T = 25° C. Rejection based on 50 Ω source, 50 Ω load)

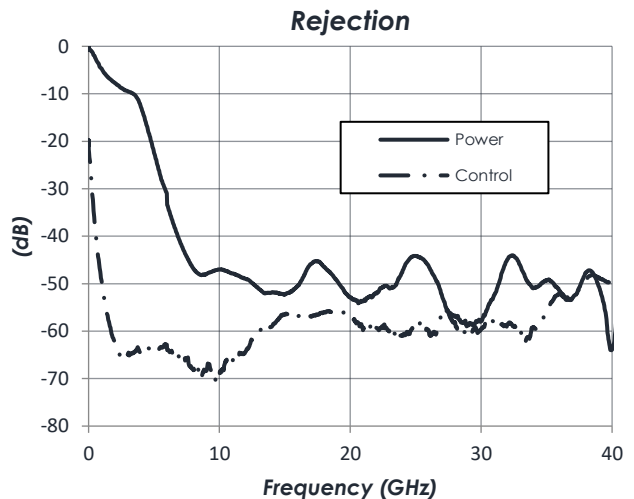
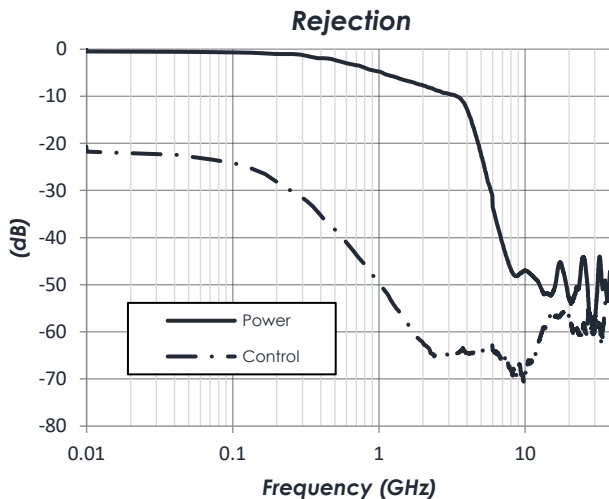

Table of Contents

Description	1	Absolute Maximum Ratings	4
Features	1	Handling Information	4
Functional Diagram	1	Recommended Operating Conditions ...	4
Characteristic Performance	1	Recommended For Use With	4
Revision History	2	Example Application	5
Pin Layout and Definitions	3	Component Compliance Information	6
Specifications	4		

Revision History

Date	Revision Number	Notes
December 20, 2018	0	Preliminary Release
April 30, 2019	1	Initial Release
June 6, 2019	1A	Component Compliance Information Updated
May 15, 2020	2	Package information moved to main product page

Pin Layout and Definitions

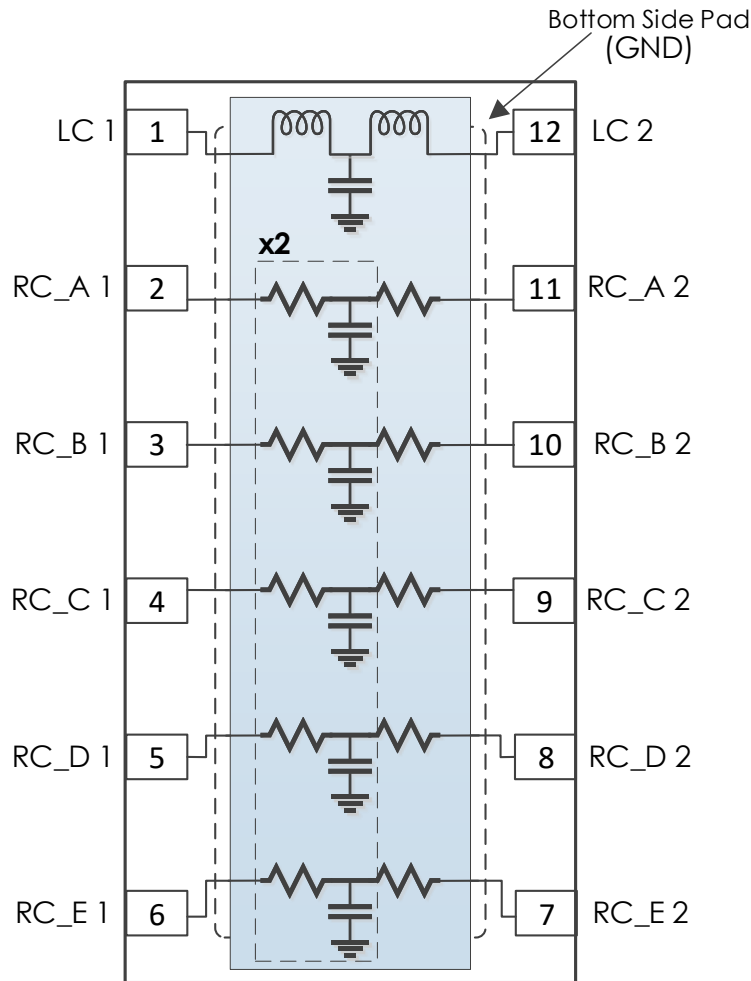

Pin Number	Pin Name	Pin Function
1	LC1	Power Line Filter Port 1
2	RC_A1	Control Line Filter A Port 1
3	RC_B1	Control Line Filter B Port 1
4	RC_C1	Control Line Filter C Port 1
5	RC_D1	Control Line Filter D Port 1
6	RC_E1	Control Line Filter E Port 1
7	RC_E2	Control Line Filter E Port 2
8	RC_D2	Control Line Filter D Port 2
9	RC_C2	Control Line Filter C Port 2
10	RC_B2	Control Line Filter B Port 2
11	RC_A2	Control Line Filter A Port 2
12	LC2	Power Line Filter Port 2
Bottom Pad	GND	Ground – Common

AM35 – EMI Filter Bank

Power and Control Line



Specifications

Absolute Maximum Ratings

	Minimum	Maximum
DC Input Voltage		20 V
DC Input Current – Power Line		160 mA
DC Input Current – Control Lines		5 mA
Storage Temperature Range	-50 C	+150 C

Note: Any device operation beyond the Absolute Maximum Ratings may result in permanent damage to the device. The values listed in this table are extremes and do not imply functional operation of the device at these or any other conditions beyond what is listed under Recommended Operating Conditions. Any part subjected to conditions outside of what is recommended for an extended amount of time may suffer from reliability concerns.

Handling Information

	Minimum	Maximum
Storage Temperature Range (Recommended)	-50 C	+125 C
Moisture Sensitivity Level	MSL 3	



Atlanta Micro products are electrostatic sensitive.
Follow safe handling practices to avoid damage

Recommended Operating Conditions

	Minimum	Typical	Maximum
Input Voltage			16 V
Input Current – Power Line			150 mA
Input Current – Control Lines			4 mA
Operating Case Temperature	-40 C		+85 C

Recommended For Use With

Part Number	Description
AM3029	1.5 GHz to 3.0 GHz Digitally Tunable Lowpass
AM3030	3.5 GHz to 6.5 GHz Digitally Tunable Lowpass
AM3039	9 GHz to 18 GHz Digitally Tunable Lowpass
AM3107	6 GHz to 12 GHz Digitally Tunable Lowpass
AM3110	18 GHz to 26.5 GHz Digitally Tunable Lowpass
AM3032	2.5 GHz to 4.5 GHz Digitally Tunable Highpass
AM3041	6 GHz to 10 GHz Digitally Tunable Highpass
AM3108	12.0 GHz to 18.0 GHz Digitally Tunable Highpass
AM3109	18 GHz to 26.5 GHz Digitally Tunable Highpass

AM35 – EMI Filter Bank

Power and Control Line



Example Application

Discretely Tunable Filter

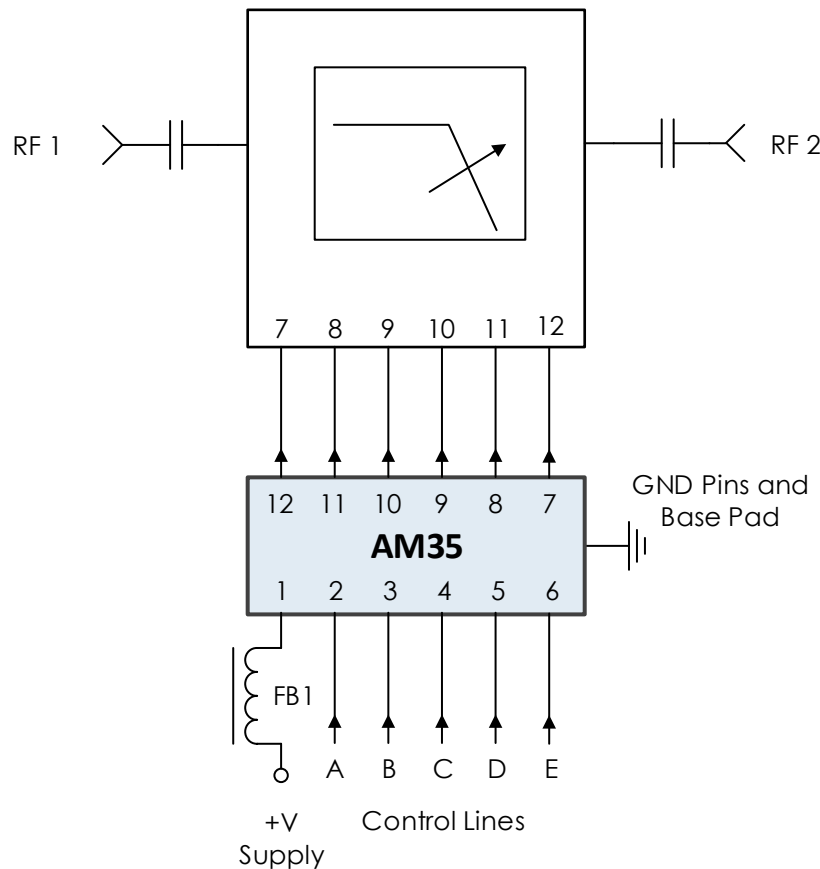

Recommended Component List (or equivalent):

Part	Value	Part Number	Manufacturer
FB1	-	MMZ1005A222E	TDK

Notes:

1. Use ferrite bead in series with power filtering line for better low frequency performance.
2. It is recommended to ground any unused pins.

Component Compliance Information

RoHS: Atlanta Micro, Inc. hereby certifies that all products comply with the EC Directive 2011/65/EC on the Restriction of Hazardous Substances, commonly known as EU-RoHS 6 and 10. All products supplied by Atlanta Micro shall be compliant with the European Directive 2011/65/EC based on the following substance list.

Substance List	Allowable Maximum Concentration
Lead (Pb)	<1000 PPM (0.1% by weight)
Mercury (Hg)	<1000 PPM (0.1% by weight)
Cadmium (Cd)	<75 PPM (0.0075% by weight)
Hexavalent Chromium (CrVI)	<1000 PPM (0.1% by weight)
Polybrominated Biphenyls (PBB)	<1000 PPM (0.1% by weight)
Polybrominated Diphenyl ethers (PBDE)	<1000 PPM (0.1% by weight)
Decabromodiphenyl Deca BDE	<1000 PPM (0.1% by weight)
Bis (2-ethylhexyl) Phthalate (DEHP)	<1000 PPM (0.1% by weight)
Butyl Benzyl Phthalate (BBP)	<1000 PPM (0.1% by weight)
Dibutyl Phthalate (DBP)	<1000 PPM (0.1% by weight)
Diisobutyl Phthalate (DIBP)	<1000 PPM (0.1% by weight)

REACH: Atlanta Micro, Inc. neither uses nor intentionally adds any of the substances considered to be a Substance of Very High Concern (SVHC) as defined by the EU Regulation (EC) No. 1907-2006 on Registration, Evaluation, Authorization, and Restriction of Chemicals (REACH).

Conflict Materials: Atlanta Micro does not knowingly use materials that are sourced from the Democratic Republic of Congo (DRC) or any other known conflict regions. Atlanta Micro's supply chain is comprised of sources that are both environmentally and socially responsible. We periodically review this requirement with our vendors to ensure continued compliance.

Atlanta Micro takes its responsibility as a global partner seriously and will use due diligence within our supply chain to ensure all standards are met to the best of our knowledge.