

# Calculating VNA Measurement Accuracy

MS4640A, 37000D

VectorStar™ and Lightning VNAs

## Introduction

Vector Network Analyzers (VNA) are your primary resource when analyzing and characterizing systems and components for RF and Microwave measurements. They are regarded as accurate measuring instruments, however, quantifying the accuracy performance of a VNA in a specific application can be challenging. VNA specifications are a starting point; but, they are based upon very specific calibration and measurement conditions, which are not applicable for many applications. The Anritsu Exact Uncertainty program (Model No. 2300-361 and available at [www.anritsu.com](http://www.anritsu.com)) is available to help you obtain the uncertainty data that is appropriate for your specific application.

The international standard, ISO/IEC 17025, promulgates the essential requirements for demonstration of the competence of testing and calibration laboratories. It covers testing and calibration performed using standard methods, non-standard methods, and laboratory-developed methods. The ability to express uncertainty of measurement is the key element of assurance of competence. Section 5.4.6 of the standards specifies the requirements of estimation of uncertainty of measurement. "A calibration laboratory, or a testing laboratory performing its own calibrations, shall have and shall apply a procedure to estimate the uncertainty of measurement for all calibrations and types of calibrations."

The Exact Uncertainty program is one method of addressing the estimation requirement.

## General Considerations

VNA performance specifications are usually presented as numeric data detailing Test Port characteristics and dynamic range parameters as shown in Figures 1 and 2. This information coupled with test condition assumptions, such as connector repeatability and cable stability, can be used to develop the measurement uncertainty curves included in VNA technical data sheets such as shown in Figure 3.

It is important to note that the information included in Figures 1 through 3 is based upon several conditions usually described in footnotes such as:

- 12 Term sliding load or specific AutoCal® models
- Default port power of  $-10$  dBm
- IFBW is 10 Hz
- Averaging is 1
- DUT S11 and S22 = 0

These are not realized in many applications so the question arises: What is the uncertainty that you should apply to your specific situation?

Model	Frequency Range (GHz)	at Ports 1 or 2		
		Standard	Option 051	Option 061 or 062
MS4647A	0.07 to 0.3 MHz	85	83	81
	0.3 to 2 MHz	102	100	98
	2 to 10 MHz	115	113	111
	0.01 to 2.5	122	119	114
	2.5 to 5	116	112	107
	5 to 20	115	111	106
	20 to 38	116	111	105
	38 to 50	116	110	104
	50 to 65	107	101	97
	65 to 67	103	97	91
67 to 70	100	91	84	

Figure 1. VectorStar VNA Dynamic Range Specifications.

Frequency Range (GHz)	Directivity (dB)	Source Match (dB)	Load Match* (dB)	Reflection Tracking (dB)	Transmission Tracking (dB)
< 0.01**	> 40	> 40	> 40	±0.08**	±0.08**
0.01 to 2.5	> 43	> 47	> 43	±0.03	±0.03
2.5 to 20	> 50	> 47	> 50	±0.03	±0.03
20 to 40	> 48	> 47	> 48	±0.03	±0.03
40 to 65	> 43	> 45	> 43	±0.09	±0.10
65 to 67	> 43	> 45	> 43	±0.09	±0.10
67 to 70	> 42	> 40	> 42	±0.30	±0.12

Figure 2. VectorStar VNA test port parameter specifications.

\* Since Residual Load Match is limited by Residual Directivity and the user test port cable, it can only be specified at Residual Directivity.

For practical considerations, derate it by ~ 8 dB for a 3670 series test port cable, to compensate for effects such as match, repeatability, bend radius, etc.

\*\* Typical performance below 300 kHz

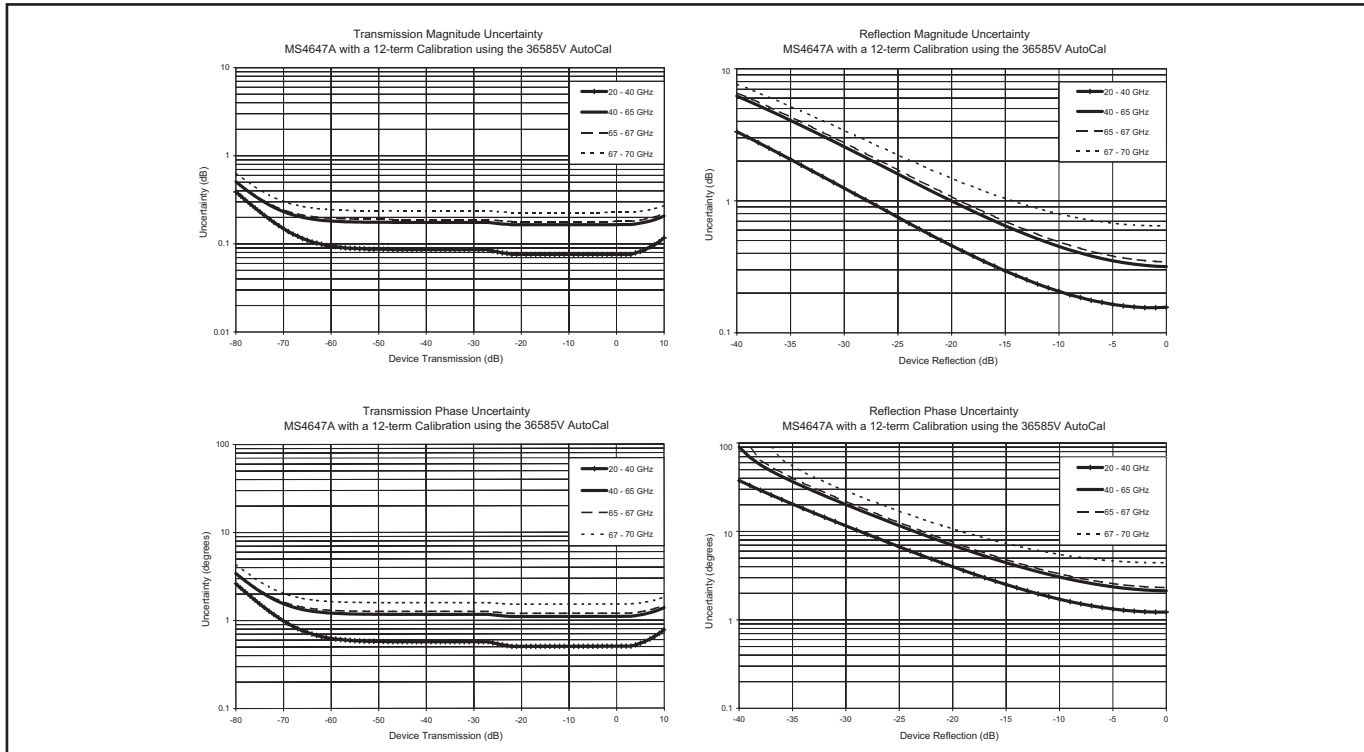

Figure 3. Typical VNA Uncertainty Specifications.

Uncertainty curves are developed from models of the measurement environment. The model for the Anritsu Exact Uncertainty program is shown in Figure 4. This model includes the important VNA effective parameters, test configuration parameters such as connector and cable performance and the Device Under Test (DUT) parameters. The model leads to equations that are quite elaborate (see Appendix A). Fortunately computers were designed for this type of calculation and you can focus on the important performance parameters and the result. The user must determine the model parameters for the specific application. In general, the important parameters are test port characteristics: directivity, source and load match, which result from the calibration process, and the noise floor of the measurement system. Directivity, source and load match specifications are available in instrument specifications for specific calibration methods and connector types; however, as mentioned above, they are also dependent upon conditions that may not be appropriate for the application being considered. If in-fixture or on-wafer measurements are involved, specifications may not be available. It is desirable to actually measure these parameters and this is readily done if a transmission line standard is available which is often the case [1].

The noise floor (NRC) in the model is an important entry that should be carefully considered. This parameter establishes the Signal to Noise (S/N) ratio for a specific measurement. For example: a 40 dB S/N ratio is fine for good operation of many systems; but, for an instrument such as a VNA, a S/N ratio of 40 dB results in an uncertainty approaching ± 0.1 dB, which may be a problem for your measurement requirement. VNA's include menu options to change the IF Bandwidth and Averaging, and these parameters can be changed to reduce the noise floor at the expense of longer measurement time. Published VNA noise floor specifications are usually specified at very narrow IF Bandwidths and/or high averaging factors that require very long and in many cases impractical sweep times. The actual noise floor for a specific IF Bandwidth and averaging factor can be accurately estimated by considering port power used during calibration and the system noise floor with both ports terminated. When changing the IF bandwidth, the Exact Uncertainty program will automatically recalculate the resultant noise floor.

## Program Operation

The Exact Uncertainty program provides two paths for calculating uncertainties for a specific application: the CONFIGURATION panel and the MODEL panel. These are available from the WINDOWS popup menu. The simplest method utilizes the Configuration panel. The more complicated, but also more controllable method utilizes the Model panel. The Model panel allows you to specify all of the individual parameters which go into the computation of uncertainty. Computation of uncertainties is actually performed on the Model. A Configuration is a simple means for creating a Model. If you desire more control over the parameters of the system, or if you wish to analyze uncertainties for special situations such as in-fixture or on-wafer measurements, use the Model rather than the Configuration.

## Uncertainty Calculations

In most cases (including the default calculations), the uncertainties computed are worst case values. All measurements will have less error than that predicted by the conservative approach taken in Exact Uncertainty. The exception is under the Model approach, the coverage factors for the uncertainty analysis can be changed to values other than those representing worst-case calculations including worst case correlation of real and imaginary parts.

## Configuration

The CONFIGURATION (default) panel is shown in Figure 5. The user can select the Anritsu VNA and the calibration kit being used as well as the frequency range of interest. Specified performance parameters are automatically included in the program. It is important to enter the actual IF Bandwidth and Averaging Factor (see Figure 6) being used as this establishes the noise parameter used in the computation.

The user can also input the specific frequencies that are important for a given measurement as shown in Figure 7. When the appropriate choices have been made, Compute Configuration will lead to the generation of uncertainty curves for the measurement situation. If the full frequency range is specified for the selected VNA, Averaging factor set to 1, and IF Bandwidth set to 10 Hz, compute configuration will result in curves similar to those in the published specifications.

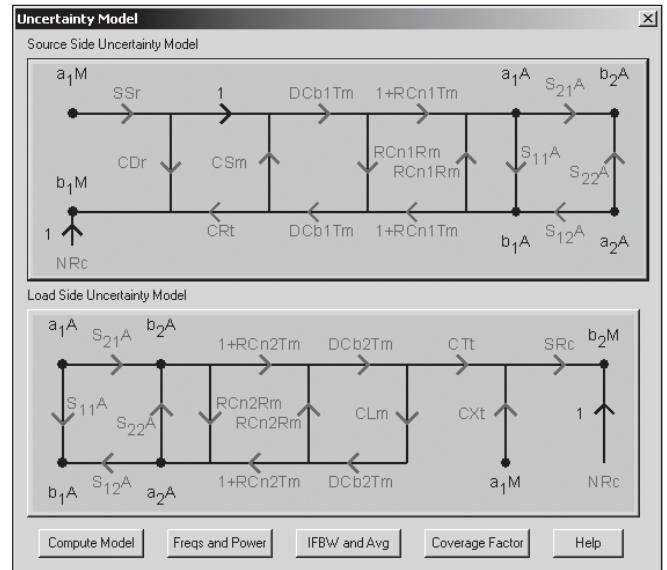

Figure 4. Flow Graph Representation of Model.

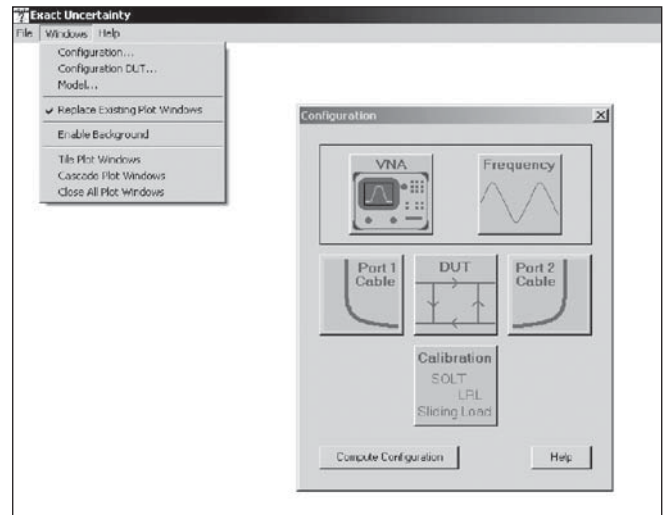

Figure 5. Configuration Window.

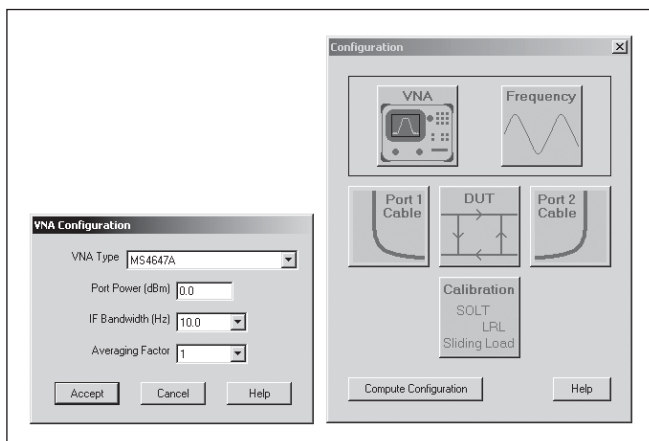

Figure 6. VNA Configuration Pop Up Menu.

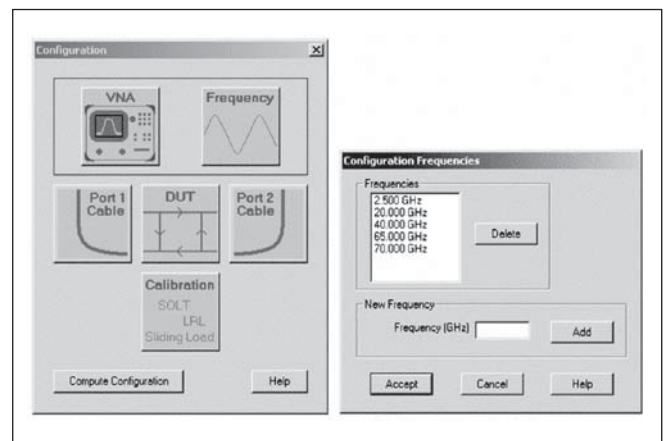

Figure 7. VNA Configuration Frequency Menu.

## *Configuration Steps*

A Configuration consists of

- 1) The type of VNA
- 2) The types of Cables on each port
- 3) The Calibration Kit

These factors determine the system uncertainty.

In addition to the factors above, the computation of uncertainty is controlled by

- 1) The range of Frequencies
- 2) The Port Power
- 3) The IF Bandwidth
- 4) The Averaging Factor
- 5) The type of DUT

The Configuration Dialog menu is used to select the equipment for which uncertainty will be calculated. The panel consists of six buttons for system configuration. The Compute Configuration button starts the calculation process once the configuration is complete.

### *VNA Configuration*

This dialog is used to choose which model of VNA you are using.

- The VNA Type list shows models of VNAs which have been defined in the Uncertainty File. Select the VNA type which most closely matches that of your VNA.
- The Port Power text is used to enter the port power in dBm which you are using. It must lie within the acceptable bounds for the selected VNA type.
- The IF Bandwidth list shows the acceptable values of the IF bandwidth for the selected type of VNA.
- The Averaging Factor list shows a range of averaging factors. Point-by-point averaging is assumed for all calculations.

### *Frequency Configuration*

This dialog is used to choose which frequencies will be used in the computation of uncertainty. Each frequency will be a different line on the uncertainty plots.

- The current set of frequencies is listed in the “Frequencies” list box.
- To remove a frequency from the list, first select it in the list box by clicking on the frequency and then press the “Delete” button. The selected frequency will be removed from the list.
- To add a frequency to the list, first type the frequency into the “Frequency (GHz)” text box and then press the “Add” button. The frequency will be added to the list.

### *Cable Configuration Dialog*

This dialog is used to enter the parameters of the port cables. The effects of cables are seen most strongly in the phase uncertainty. The combination of dielectric type, length, temperature and frequency produce a phase uncertainty in the measured data. For more control over the phase uncertainty, use the Model rather than the Configuration. If you desire to eliminate the effects of phase from the port cables in the computation of uncertainty, just enter a length of 0 for both the port cables.

The Dielectric list shows types of dielectrics which have been defined in the Uncertainty File. Select the dielectric type which most closely matches that of your cable.

- The Length text is used to enter the length in meters.
- The Temperature Variation text is used to enter the range of temperature, in Celsius, that the cables will experience.

## Calibration Configuration

This dialog is used to enter the type of calibration kit which is used to calibrate the VNA. Residual calibration uncertainty is usually the dominant source of VNA uncertainty. The Calibration Kit list shows calibration kits which have been defined in the Uncertainty File. Select the calibration kit which is being used to calibrate your system.

Note: Selecting a calibration kit sets the type of connectors whose repeatability will be used when computing the uncertainty.

## DUT Configuration

This dialog is used to choose which type of DUT you wish to use when computing uncertainty.

The DUT Type list shows types of DUTs. A choice of either Transmission Only or Reflection Only enables the Values text boxes. Transmission Only means the Values refer to the device  $S_{21}$ . Reflection Only means the Values refer to the device  $S_{11}$ . A choice of User Defined enables the User Defined text boxes. Transmission assumes reciprocity unless the box is unchecked (in which case  $S_{12}$  will be set to the reverse transmission value). A frequency sweep is available in the case of a User Defined DUT.

- The Minimum Value text is used to enter the starting value in dB for the device's S-parameter.
- The Maximum Value text is used to enter the ending value in dB for the device's S-parameter.
- The Number of Values text is used to enter the number of values between the starting and ending values.
- The User Defined S-parameter text boxes are used to enter a particular value for a DUT which has both transmission and reflection characteristics. If the frequency sweep is selected; the start, stop and number of frequency points may be entered in the lower text boxes.

## Model Menu

The MODEL menu gives the user complete freedom to enter parameters associated with a given measurement environment leading to uncertainty curves for that specific situation. The MODEL is shown in Figure 4. The user can select any parameter such as Port 1 directivity - CDr, and a window will appear as shown in Figure 8. This enables the user to enter parameters appropriate for the calibration. The NRc was discussed above. It is recommended that this Figure be obtained for an IFBW of 10 Hz and an averaging factor of 1. Once these parameters are entered into the model and in the lower section of Figure 9 the user can change them in the upper section and the program will automatically adjust NRc for uncertainty computation. When all parameters are defined Compute Model will provide the uncertainty for the application.

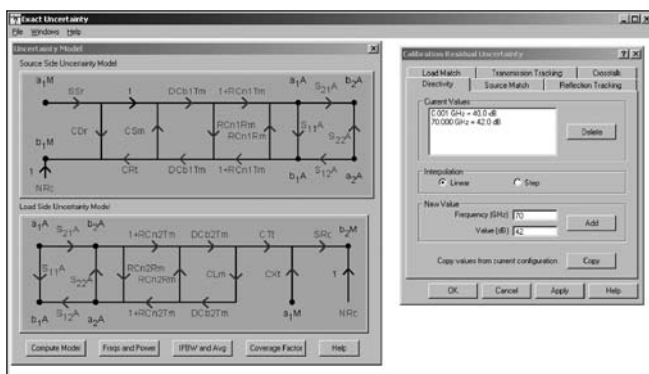

Figure 8. Model Directivity Panel.

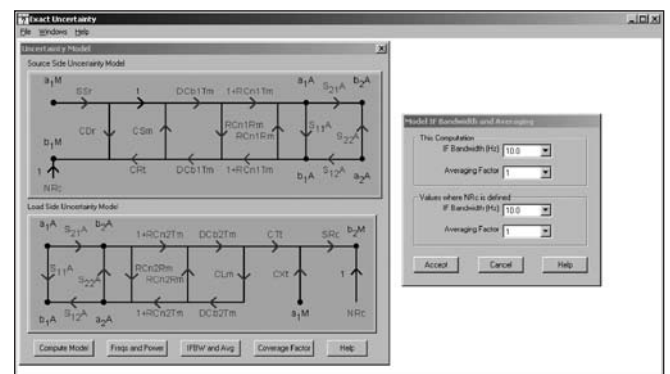

Figure 9. Model IFBW and Averaging Panel.

A good example of program use is the measurement of a microstrip device in a fixture. The Anritsu Universal Test Fixture (UTF) Model 3680 will be used. Calibration standards are available for in-fixture calibration, such as the 36804-15M, which is appropriate for 15 mil Alumina microstrip. In-fixture calibration standards are desirable as they eliminate the problems associated with de-embedding adapters or launchers. However, in this situation the important effective calibration parameters, directivity and port match, must be estimated. The 36804-15M does include a long line and an offset termination. These can be measured and the data analyzed using ripple techniques to determine the desired parameters. Figures 10 and 11 show the data and include the directivity and port match appropriate for this application. The system noise floor can be determined for the application, which requires specifying Averaging and IF bandwidth for the test. In this case the noise floor was  $-115$  dBm. Entering these parameters into the program provides the uncertainty curves shown in figures 12 and 13.

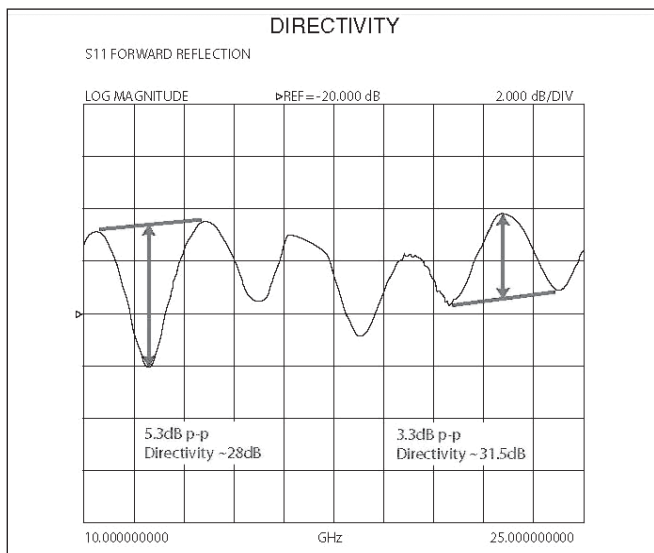

Figure 10. Ripple Pattern - Directivity.

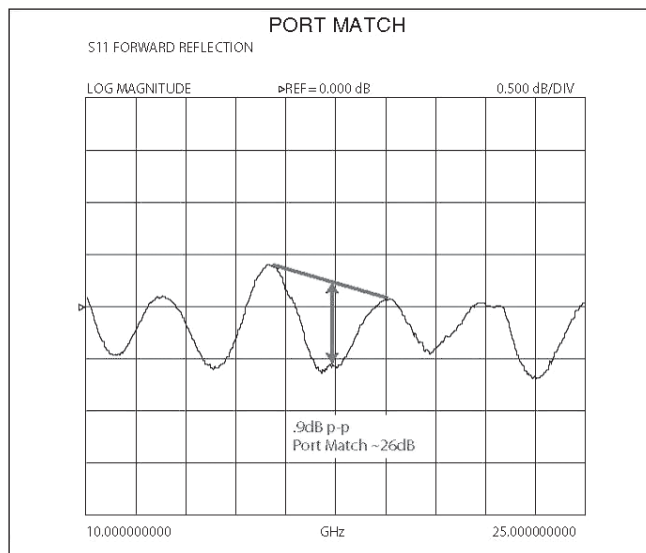

Figure 11. Ripple Pattern - Port Match.

To this point the curves generated are for an ideal DUT,  $S_{11}$  and  $S_{22} = 0$  and  $S_{21}$  and  $S_{12} = 1$ . The S-parameter characteristics of the DUT can be included in the computation by selecting User Defined in the DUT menu as shown in Figure 14. Compute model then results in a table as shown in Figure 15 which presents the uncertainties at specified frequencies for the measurements being made.

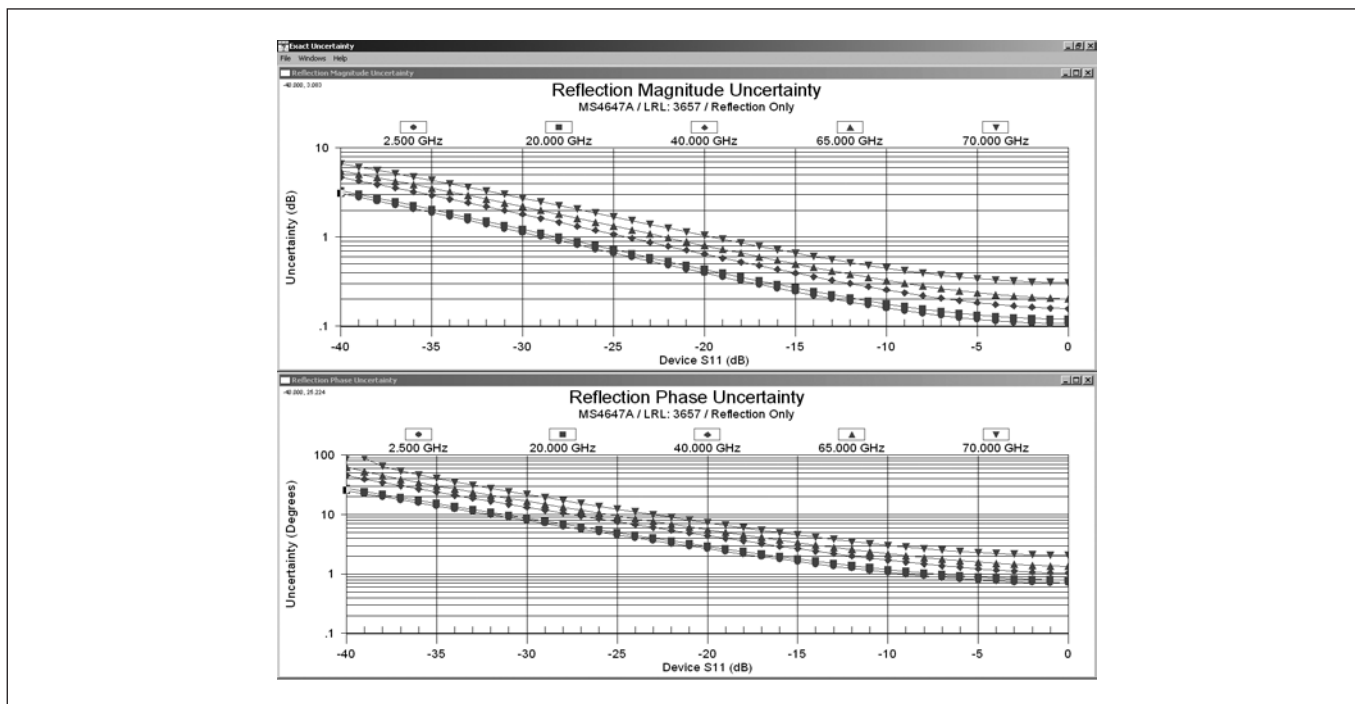

Figure 12. Reflection ( $S_{11}$ ) Uncertainty Curves.

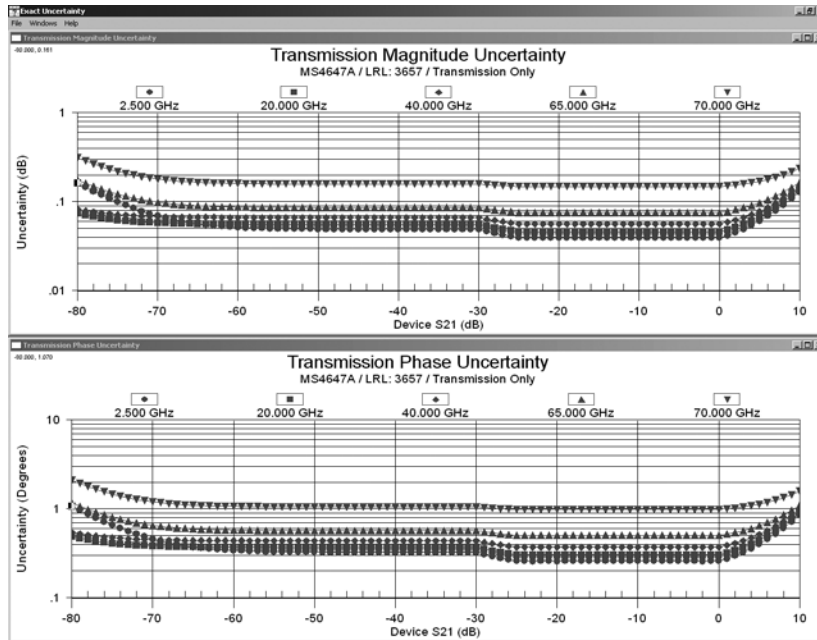

Figure 13. Transmission ( $S_{21}$ ) Uncertainty Curves.

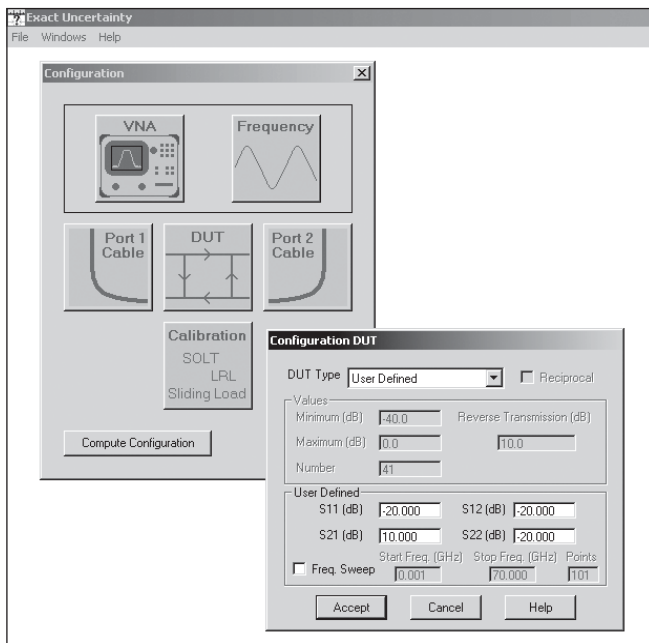

Figure 14. DUT Parameter Panel.

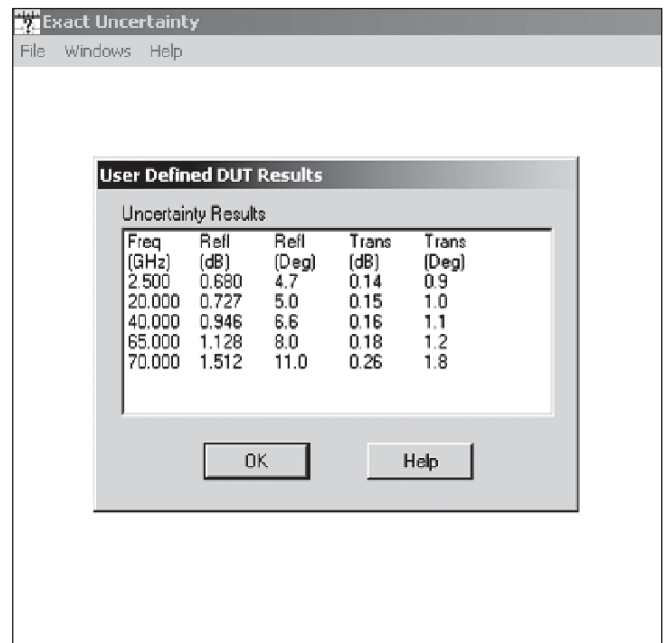

Figure 15. Uncertainty, Considering DUT Parameters.

## Defining the Model

A model is the mathematical basis from which system uncertainty is computed. The model part of the program is designed to allow advanced users to investigate system uncertainty using parameters other than the defaults.

The model used to compute uncertainties has 17 terms.

The VNA is described by:

SSr: Systematic uncertainty of the source

SRc: Systematic uncertainty of the receiver

NRc: Noise floor of the receiver

The Cables are described by:

DCb1Tm: Drift of the cable on port 1 in terms of transmission magnitude

DCb1Tp: Drift of the cable on port 1 in terms of transmission phase

DCb2Tm: Drift of the cable on port 2 in terms of transmission magnitude

DCb2Tp: Drift of the cable on port 2 in terms of transmission phase

The Connectors are described by:

RCn1Tm: Repeatability of the connector on port 1 in terms of transmission magnitude.

RCn1Rm: Repeatability of the connector on port 1 in terms of reflection magnitude.

RCn2Tm: Repeatability of the connector on port 2 in terms of transmission magnitude.

RCn2Rm: Repeatability of the connector on port 2 in terms of reflection magnitude.

The Calibration is described by:

CDr: Residual directivity error

CSm: Residual source match error

CRt: Residual reflection tracking error

CXt: Residual crosstalk error

CLm: Residual load match error

CTt: Residual transmission tracking error

In addition to the 17 terms above, the DUT is described by the four scattering parameters for a two port network:

$S_{11}$

$S_{12}$

$S_{21}$

$S_{22}$

Most of the error terms refer to magnitude quantities. Only the cable phase drift quantities DCb1Tp and DCb2Tp refer to phase. In order to compute the phase uncertainty, the magnitude uncertainty is first computed. The maximum uncertainty in phase due to a magnitude error is then computed. The cable phase uncertainties are then added to this quantity to give the final phase uncertainty.

## VNA Model

The VNA test set uncertainty model (Figure 16) is described by systematic uncertainty terms and noise terms which quantify the uncertainties resulting from the source or receiver parts of the VNA.

SSr is the systematic uncertainty of the source. Values are entered as, for example, 0.01 dB at some frequency. This means that the source-related uncertainty is 0.01 dB at that frequency. The systematic uncertainty of the source includes the reversing switch repeatability.

SRc is the systematic uncertainty of the receiver. Values are entered as, for example, 0.1 dB at some receiver power level. This means that the uncertainty is 0.1 dB at that power level (this power level is referred to the port). The systematic uncertainty of the receiver models the effects of compression and gain uncertainty in the receiver channel. Note that a special interpolation option is available for SRc termed 'Smooth Fit' which better mimics physical compression behavior than does Linear interpolation.

NRc is the noise floor of the receiver. Values are entered as, for example, 80 dB at some frequency. This means that the error term is 80 dB down at that frequency.

The port power is the power flowing out of the front panel port in dBm. The port power for the Configuration must fit within acceptable bounds for the type of VNA you are using. In the Model the power is allowed to have any value as long as the SRc term is defined for the resulting power levels.

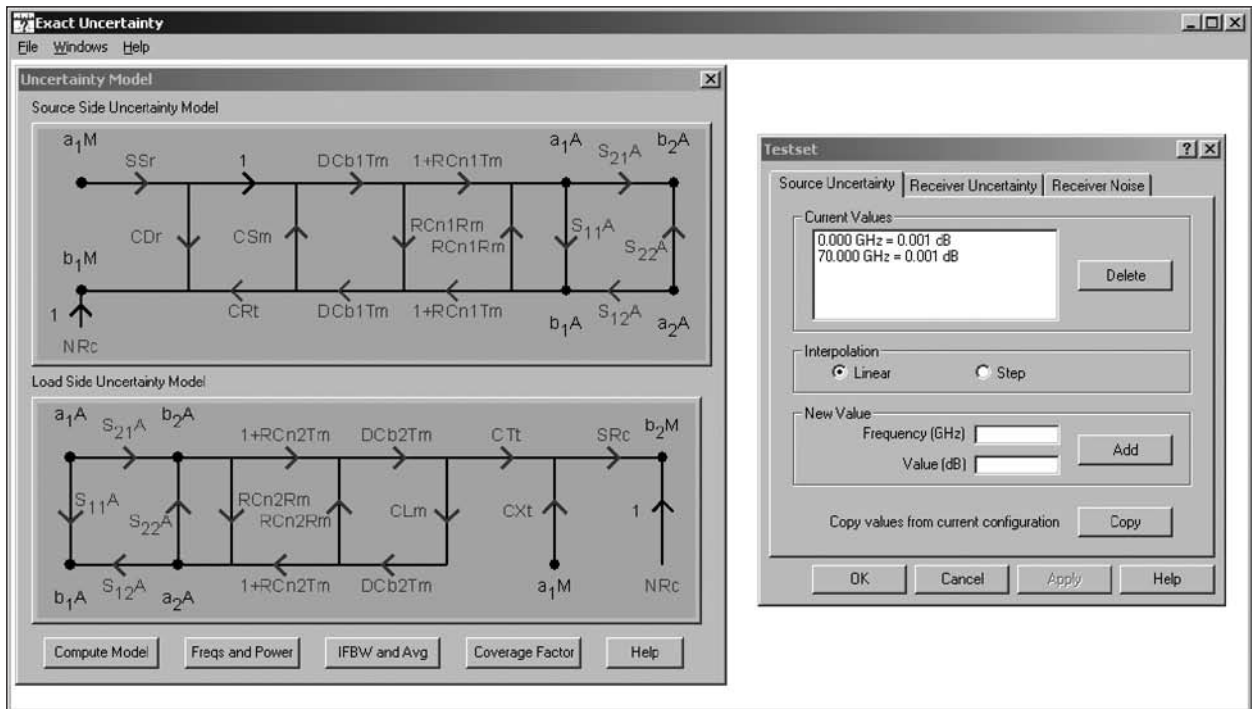

Figure 16. VNA Test Set Uncertainty Model.

## Cable Model

The cable uncertainty model (Figure 17) is described by drift uncertainty terms which quantify the uncertainties resulting from the temperature drift of the port cables.

DCb1Tm and DCb2Tm are the repeatability of the transmission magnitude for the cables on ports 1 and 2, respectively. Values are entered as, for example, 0.01 dB at some frequency. This means that the added uncertainty is 0.01 dB at that frequency.

DCb1Tp and DCb2Tp are the repeatability of the transmission phase for the cables on ports 1 and 2, respectively. Values are entered as, for example, 0.5 degrees at some frequency. This means that the error is 0.5 degrees at that frequency.

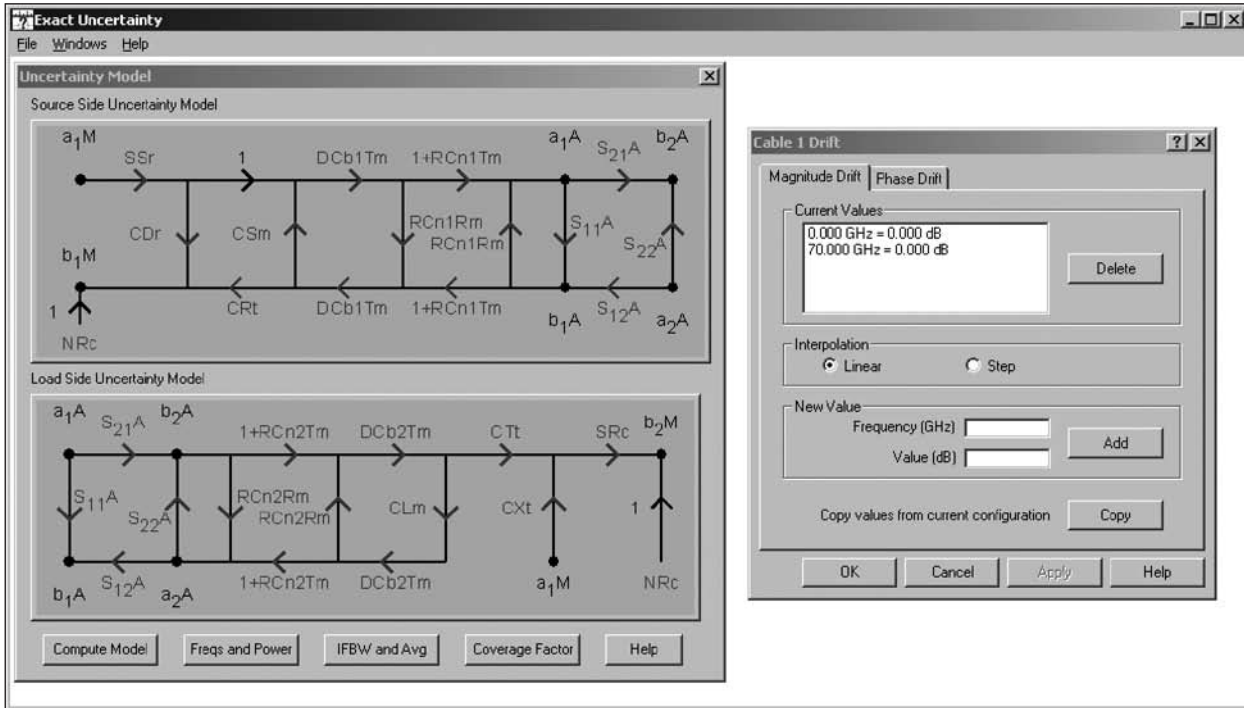

Figure 17. Cable Uncertainty Model.

## Connector Model

The connector uncertainty model (Figure 18) is described by repeatability uncertainty terms which quantify the uncertainties resulting from the finite repeatability of connectors.

RCn1Tm and RCn2Tm are the repeatability of the transmission magnitude for the connectors on ports 1 and 2, respectively. Values are entered as, for example, 60 dB at some frequency. This means that the error term is 60 dB down at that frequency.

RCn1Rm and RCn2Rm are the repeatability of the reflection magnitude for the connectors on ports 1 and 2, respectively. Values are entered as, for example, 60 dB at some frequency. This means that the error term is 60 dB down at that frequency.

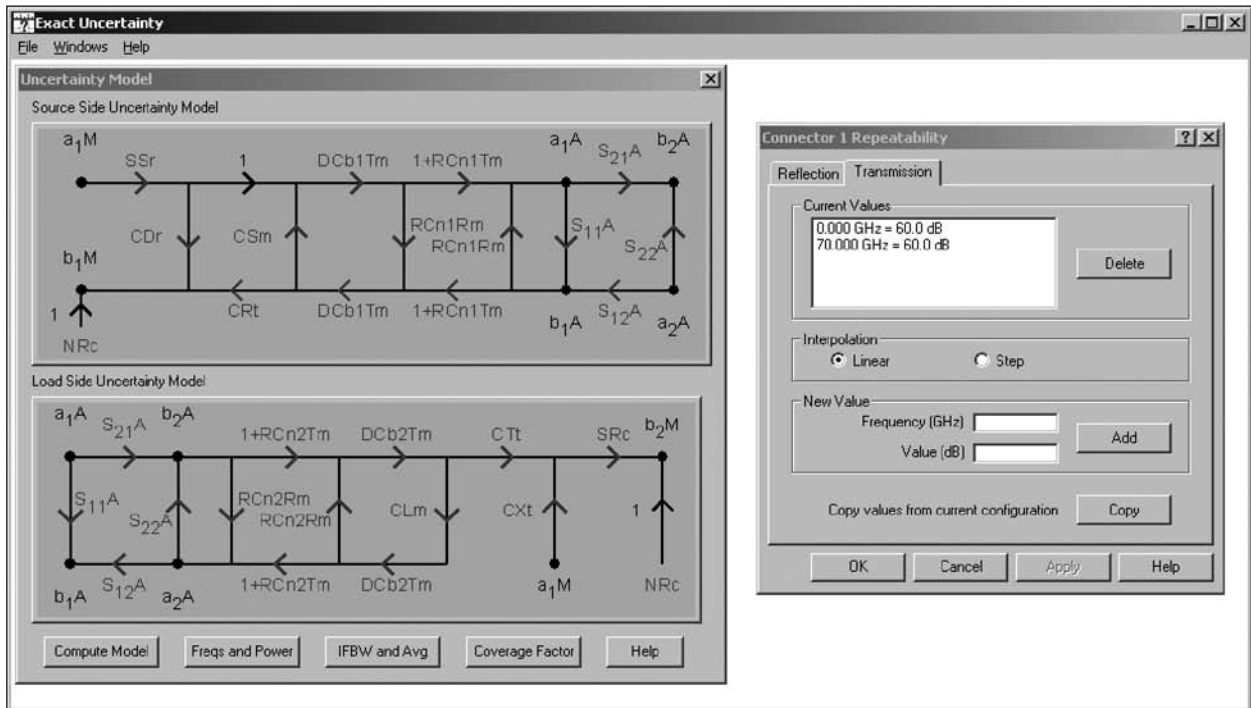

Figure 18. Connector Uncertainty Model.

## Calibration Model

The calibration uncertainty model (Figure 19) is described by residual error terms which quantify the uncertainty which remain after a calibration is completed.

CDr is the residual directivity error. Values are entered as, for example, 40 dB at some frequency. This means that the error term is 40 dB down at that frequency.

CSm is the residual source match. Values are entered as, for example, 40 dB at some frequency. This means that the error term is 40 dB down at that frequency.

CRT is the residual reflection tracking error. Values are entered as, for example, 0.05 dB at some frequency. This means that the uncertainty is 0.05 dB at that frequency.

CXt is the residual crosstalk error. Values are entered as, for example, 100 dB at some frequency. This means that the error term is 100 dB down at that frequency.

CLm is the residual load match error. Values are entered as, for example, 40 dB at some frequency. This means that the error term is 40 dB down at that frequency.

CTt is the residual transmission tracking error. Values are entered as, for example, 0.01 dB at some frequency. This means that the uncertainty is 0.01 dB at that frequency.

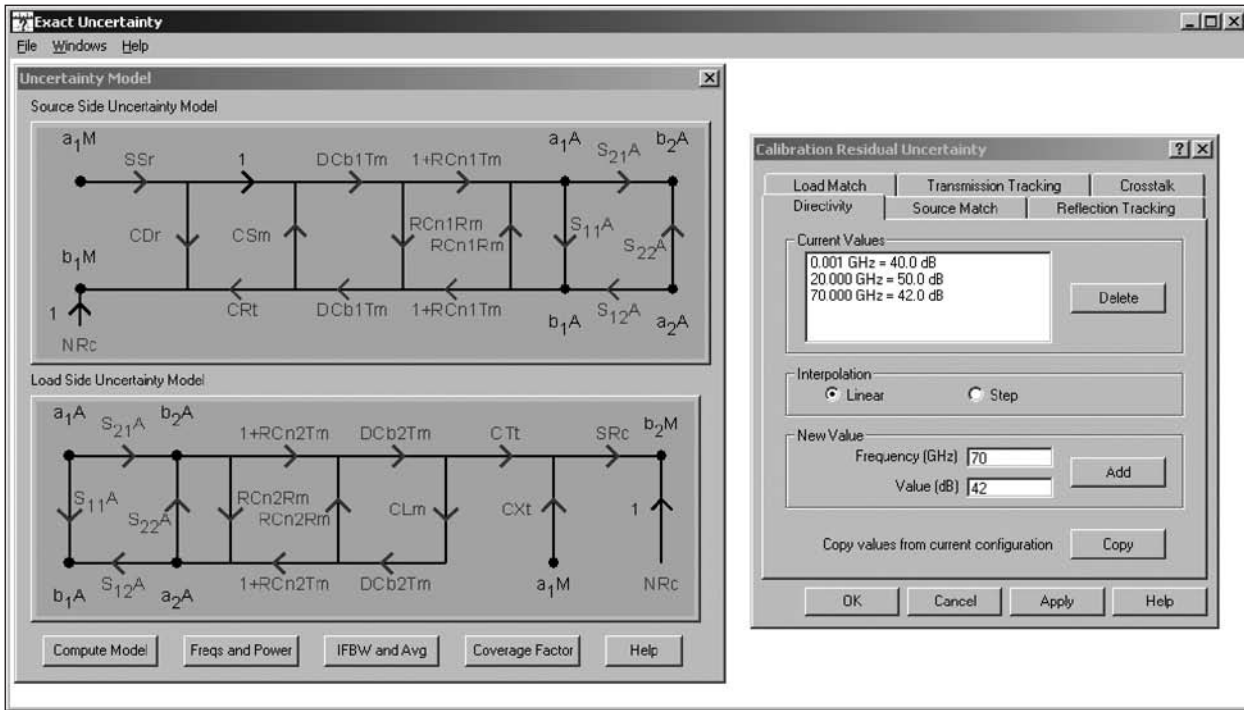

Figure 19. Calibration Uncertainty Model.

## DUT Model

There are three types of DUT for which uncertainty can be calculated: Reflection Only, Transmission Only and User Defined. The Reflection Only and Transmission Only DUTs are used to compute uncertainty curves similar to those published in data sheets. However, these two types of DUT do not represent most real measurement scenarios. To compute the uncertainty for a DUT with realistic values for the S-parameters, the User Defined DUT may be used.

The Reflection Only DUT has values of  $S_{11}$  which vary over a range of values which is chosen by the user.  $S_{21}$  is zero (-200 dB).  $S_{22}$  and  $S_{12}$  values do not figure into the uncertainty. The horizontal axis on plots will be  $|S_{11}|$  for this selection.

The Transmission Only DUT has values of  $S_{21}$  and  $S_{12}$  which vary over a range of values which is chosen by the user.  $S_{21}$  and  $S_{12}$  have the same value if the reciprocal box is checked (otherwise  $S_{12}$  will be set to the reverse transmission value and not swept).  $S_{11}$  and  $S_{22}$  are zero (-200 dB). The horizontal axis on plots will be  $|S_{21}|$  for this selection.

Exact Uncertainty was created to allow users to easily and realistically assess the uncertainties of their measurements. While the Reflection Only and Transmission Only DUTs represent the ways in which uncertainty curves have been presented in the past, they have usually underestimated the true measurement uncertainty. Users can get the most accurate estimate of uncertainty by using the User Defined DUT.

The User Defined DUT allows magnitude numbers in dB to be entered for all four S-parameters. Because of the way that the multiple uncertainties in the model interact, the scattering parameters of the DUT play a strong role in the resulting uncertainty. In most situations, the resulting uncertainty when using a DUT with non-zero values will exceed that computed using the Reflection Only or Transmission Only DUTs. Frequency sweep is an option for this selection and, if chosen, will result in a horizontal axis of frequency. If the frequency sweep is not selected, output for this selection will be tabular.

## Coverage Factor

A coverage factor option is available under the Model setup (Figure 20) where the coverage factor for the model inputs as well as the output calculation may be entered. The values all default to 4.0 which represents a quasi-worst case scenario (since this is how VNA specifications are normally quoted) Use caution when changing these values and be sure to understand the nature of the input parameters.

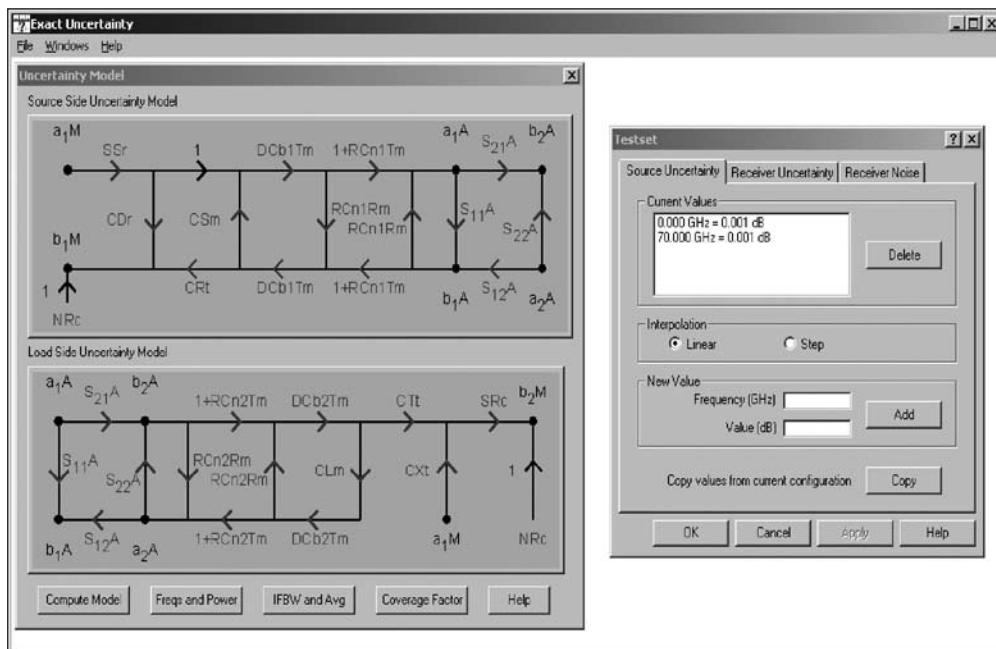

Figure 20. Designating Coverage Factors.

## Customizing the Program

### *Configuration File*

When the program starts, it attempts to read a configuration file called “default.cfg” which is located in the same directory as the program. If the file cannot be located or an error occurs while reading the file, the program will terminate. In addition, Exact Uncertainty can save and recall configurations. The program can therefore start with some configuration which you define. Simply create the configuration and then save it using the name “default.cfg”.

### *Model File*

Exact Uncertainty can save and recall models. When the program starts, it attempts to read a model file called “default.mdl” which is located in the same directory as the program. If the file cannot be located or an error occurs while reading the file, the program will terminate. As with Configuration files, the Exact Uncertainty program can save and recall models. The program can start with a specific model that you define. Simply create the model and then save it using the name “default.mdl”.

## Conclusion

An easy to use program has been developed that enables the VNA user to estimate the uncertainty appropriate for conditions associated with a specific measurement. This will enable users to meet the uncertainty analysis requirements of the ISO standards. A practical measurement example was examined that demonstrates the utility of the program.

## Appendix A

### Computation of Uncertainty

The uncertainty model used by Exact Uncertainty is shown in Figures A1 and A2. Because of the large size of the model, the drawings show the model in two halves, the source side and the load side. The location of the DUT is repeated to show the connection between the two halves of the model.

When computing the uncertainty, the model is first combined using signal flow graph mathematics, to the condensed model shown in Figure A3. Much of the model has been combined into the M two-port.

The next steps in computing the uncertainty involve the computation of the received powers, leading to the determination of the compression and noise effects.

The input power at the VNA ports (IP1 and IP2 in Figure A3) are found from the user selected port power (PP in Figure A3) and the DUT values as

$$IP1=PP+S_{11}^A \quad \text{and} \quad IP2=PP+S_{21}^A$$

where the powers are in dBm and  $S_{11}^A$  and  $S_{21}^A$  are in dB.

The received powers (RP1 and RP2) are assumed equal to the input powers (IP1 and IP2).

The receiver compression term SRc is computed for each port of the VNA based on the received power. Thus, SRc1 is the compression uncertainty term for port 1 of the VNA and is computed based on the value of RP1. Likewise, SRc2 is the compression uncertainty term for port 2 of the VNA and is computed based on the value of RP2. The computation is an interpolation of the user entered values for the SRc term.

The effects of receiver noise on uncertainty, NRc1 and NRc2, are computed from the noise of the receiver (NRc) and the received powers (RP1 and RP2) as

$$NR_{c1} = \sqrt{\frac{NR_c}{RP1}} M_{11} \quad \text{and} \quad NR_{c2} = \sqrt{\frac{NR_c}{RP2}} M_{21}$$

where the powers are in Watts and the M's are linear (not dB).

Based on the previous computations, the uncertainties for  $S_{11}$  and  $S_{21}$  ( $U_{11}$  and  $U_{21}$ ) are now computed as

$$U_{11}=SSr \times M_{11} \times SRc1 + NRc1 \quad \text{and} \quad U_{21}=(SSr \times M_{21} + CXt) \times SRc2 + NRc2$$

where all of the terms are linear (not dB).

The phase uncertainty is computed as

$$PU_{11} = \sin^{-1} \left( \frac{U_{11} - S_{11}^A}{S_{11}^A} \right) + DCb1Tp \times 2 \quad \text{and} \quad PU_{21} = \sin^{-1} \left( \frac{U_{21} - S_{21}^A}{S_{21}^A} \right) + DCb1Tp + DCb2Tp$$

where all terms on the right sides of the equations are linear (not dB). This is the phase uncertainty which is displayed in the plots.

The magnitude uncertainty which is displayed in the plots is

$$MU_{11}=U_{11}-S_{11}^A \quad \text{and} \quad MU_{21}=U_{21}-S_{21}^A$$

where all values are in dB.

### References

- 1) Bill Oldfield, "VNA  $S_{11}$  Uncertainty Measurement – A Comparison of Three Techniques", ARFTG Conf. Dig., June 1992.

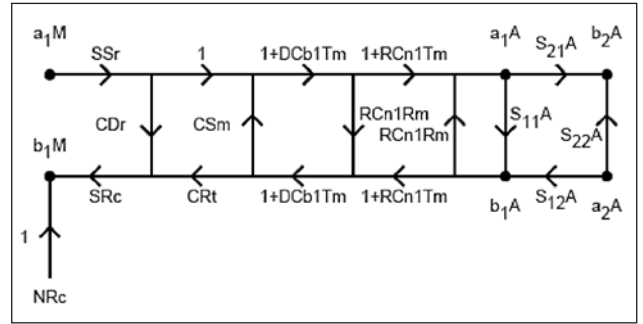

Figure A1. Source Side Uncertainty Model.

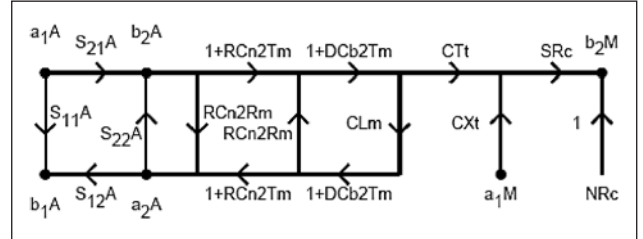

Figure A2. Load Side Uncertainty Model.

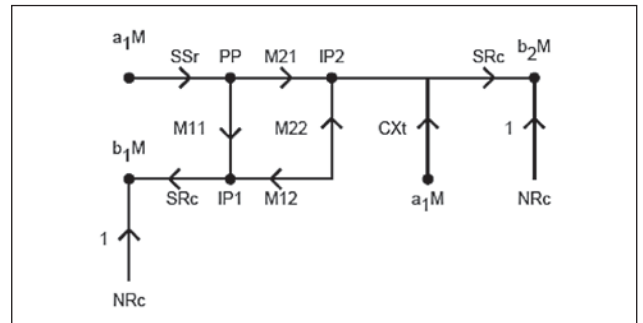

Figure A3. Condensed Uncertainty Model.

# Anritsu

## Anritsu Corporation

5-1-1 Onna, Atsugi-shi, Kanagawa, 243-8555 Japan  
Phone: +81-46-223-1111  
Fax: +81-46-296-1264

### • U.S.A.

#### Anritsu Company

1155 East Collins Boulevard, Suite 100,  
Richardson, Texas 75081 U.S.A.  
Toll Free: 1-800-ANRITSU (267-4878)  
Phone: +1-972-644-1777  
Fax: +1-972-671-1877

### • Canada

#### Anritsu Electronics Ltd.

700 Silver Seven Road, Suite 120, Kanata,  
Ontario K2V 1C3, Canada  
Phone: +1-613-591-2003  
Fax: +1-613-591-1006

### • Brazil

#### Anritsu Eletrônica Ltda.

Praca Amadeu Amaral, 27-1 Andar  
01327-010 - Paraiso, São Paulo, Brazil  
Phone: +55-11-3283-2511  
Fax: +55-11-3886940

### • Mexico

Anritsu Company, S.A. de C.V.  
Av. Ejército Nacional No. 579 Piso 9, Col. Granada  
11520 México, D.F., México  
Phone: +52-55-1101-2370  
Fax: +52-55-5254-3147

### • U.K.

#### Anritsu EMEA Ltd.

200 Capability Green, Luton, Bedfordshire LU1 3LU, U.K.  
Phone: +44-1582-433280  
Fax: +44-1582-731303

### • France

#### Anritsu S.A.

16/18 Avenue du Québec-SILIC 720  
91961 COURTABOEUF CEDEX, France  
Phone: +33-1-60-92-15-50  
Fax: +33-1-64-46-10-65

### • Germany

#### Anritsu GmbH

Nemetschek Haus, Konrad-Zuse-Platz 1  
81829 München, Germany  
Phone: +49 (0) 89 442308-0  
Fax: +49 (0) 89 442308-55

### • Italy

#### Anritsu S.p.A.

Via Elio Vittorini, 129, 00144 Roma, Italy  
Phone: +39-06-509-9711  
Fax: +39-06-502-2425

### • Sweden

#### Anritsu AB

Borgafjordsgatan 13, 164 40 Kista, Sweden  
Phone: +46-8-534-707-00  
Fax: +46-8-534-707-30

### • Finland

#### Anritsu AB

Teknobulevardi 3-5, FI-01530 Vantaa, Finland  
Phone: +358-20-741-8100  
Fax: +358-20-741-8111

### • Denmark

#### Anritsu A/S

Kirkebjerg Allé 90 DK-2605 Brøndby, Denmark  
Phone: +45-72112200  
Fax: +45-72112210

### • Spain

#### Anritsu EMEA Ltd.

#### Oficina de Representación en España

Edificio Veganova  
Avda de la Vega, nº 1 (edf 8, pl1, of 8)  
28108 ALCOBENDAS - Madrid, Spain  
Phone: +34-914905761  
Fax: +34-914905762

### • Russia

#### Anritsu EMEA Ltd.

#### Representation Office in Russia

Tverskaya str. 16/2, bld. 1, 7th floor.  
Russia, 125009, Moscow  
Phone: +7-495-363-1694  
Fax: +7-495-935-8962

### • United Arab Emirates

#### Anritsu EMEA Ltd.

#### Dubai Liaison Office

P O Box 500413 - Dubai Internet City  
Al Thuraya Building, Tower 1, Suite 701, 7th Floor  
Dubai, United Arab Emirates  
Phone: +971-4-3670352  
Fax: +971-4-3688460

### • Singapore

#### Anritsu Pte. Ltd.

60 Alexandra Terrace, #02-08, The Comtech (Lobby A)  
Singapore 118502  
Phone: +65-6282-2400  
Fax: +65-6282-2533

### • India

#### Anritsu Pte. Ltd.

#### India Branch Office

3rd Floor, Shri Lakshminarayan Niwas,  
#2726, 80 ft Road, HAL 3rd Stage, Bangalore - 560 075, India  
Phone: +91-80-4058-1300  
Fax: +91-80-4058-1301

### • P. R. China (Hong Kong)

#### Anritsu Company Ltd.

Units 4 & 5, 28th Floor, Greenfield Tower, Concordia Plaza,  
No. 1 Science Museum Road, Tsim Sha Tsui East,  
Kowloon, Hong Kong, P.R. China  
Phone: +852-2301-4980  
Fax: +852-2301-3545

### • P. R. China (Beijing)

#### Anritsu Company Ltd.

#### Beijing Representative Office

Room 2008, Beijing Fortune Building,  
No. 5, Dong-San-Huan Bei Road,  
Chao-Yang District, Beijing 100004, P.R. China  
Phone: +86-10-6590-9230  
Fax: +82-10-6590-9235

### • Korea

#### Anritsu Corporation, Ltd.

8F Hyunjuk Bldg. 832-41, Yeoksam-Dong,  
Kangnam-ku, Seoul, 135-080, Korea  
Phone: +82-2-553-6603  
Fax: +82-2-553-6604

### • Australia

#### Anritsu Pty Ltd.

Unit 21/270 Ferntree Gully Road, Notting Hill  
Victoria, 3168, Australia  
Phone: +61-3-9558-8177  
Fax: +61-3-9558-8255

### • Taiwan

#### Anritsu Company Inc.

7F, No. 316, Sec. 1, Neihu Rd., Taipei 114, Taiwan  
Phone: +886-2-8751-1816  
Fax: +886-2-8751-1817

