

MICROWAVE CONTROL DEVICES

elisra *electronic
systems ltd.*
Microwave Division

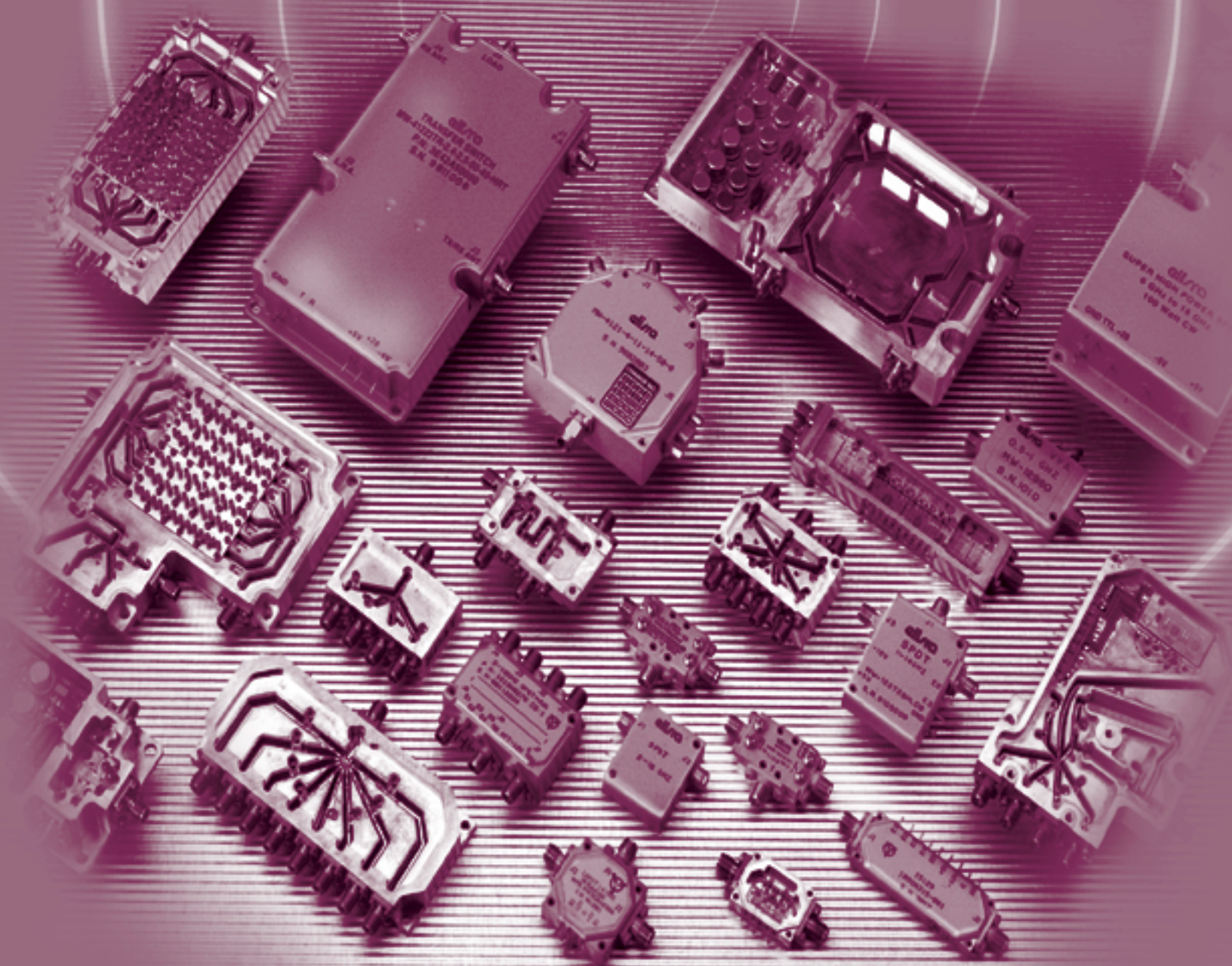

Warranty Elisra warrants products of its manufacture to be free from defects in material and workmanship under conditions of normal use. If within one year after delivery to the original owner and after prepaid return by the original owner, any product is found to be defective, Elisra shall, at its option, repair or replace said defective unit. This warranty does not apply to products which have been disassembled, modified or subjected to conditions exceeding the applicable specifications or ratings. In addition, this warranty does not apply to tubes, transistors, diodes, and fuses. Elisra reserves the right to make design changes without notice on any of its products without any obligation to make the same or similar changes to units previously purchased. In no event does Elisra assume liability for installation, labor or for consequential damages. This warranty is the extent of the obligation or liability assumed by Elisra with respect to its products, and no other warranty or guarantee is either expressed or implied.

Elisra, the Elisra logo are trademarks of Elisra Electronic Systems Ltd. Other company and brand, product and service names are trademarks or registered trademarks of their respective holders. Specifications are subject to change without notice.

Microwave Control Devices

T A B L E O F C O N T E N T S

PREFACE

Meet Elisra	4
-------------	---

CONTROL DEVICES

Microwave PIN Diode Switches

General Information	8
SPST Series MW 121T	10
SP2T Series MW 122T	13
SP3T Series MW 123T	16
SP4T Series MW 124T	19
SP5T Series MW 125T	22
SP6T Series MW 126T	25
SP8T Series MW 128T	28
Transfer Switches Series MW12TR	31

High Power PIN Diode Switches

General Information	33
SPST Through SP8T Series MW 41212XY	34
Cellular PCS and ISM	36

Modulators and Translators

Modulators with Driver	39
Frequency Translator	41

Mixers

General Information	43
Low and High Frequency Mixers	45

Attenuators

Digitally Controlled Attenuators	49
Step Attenuators	52

ORDERING ADDRESS

48 Mivtza Kadash Street
Bene-Beraq 51203, Israel
Tel: 972-3-617 5655 Fax: 972-3-617 5299
www.mw-elisra.com Email: trm1@elisra.com

Meet Elisra

Your Source for Quality RF and Microwave Components and Subsystems



Elisra Electronic Systems is a recognized leader in sophisticated electronic systems and components for defense and civilian markets.

Elisra Microwave Division has over 30 years of proven experience in supplying best-of-class components and subassemblies for a wide variety of

RF and Microwave applications covering the frequency range of 1 MHz to 50 GHz. Modern production facilities operating under a stringent framework of quality assurance standards have established Elisra as a worldclass and preferred supplier of products with unsurpassed reliability.



Our company's highly skilled teams of engineers and technicians, renowned for their technological expertise, have been the cornerstone of our leadership status in both military and commercial markets.

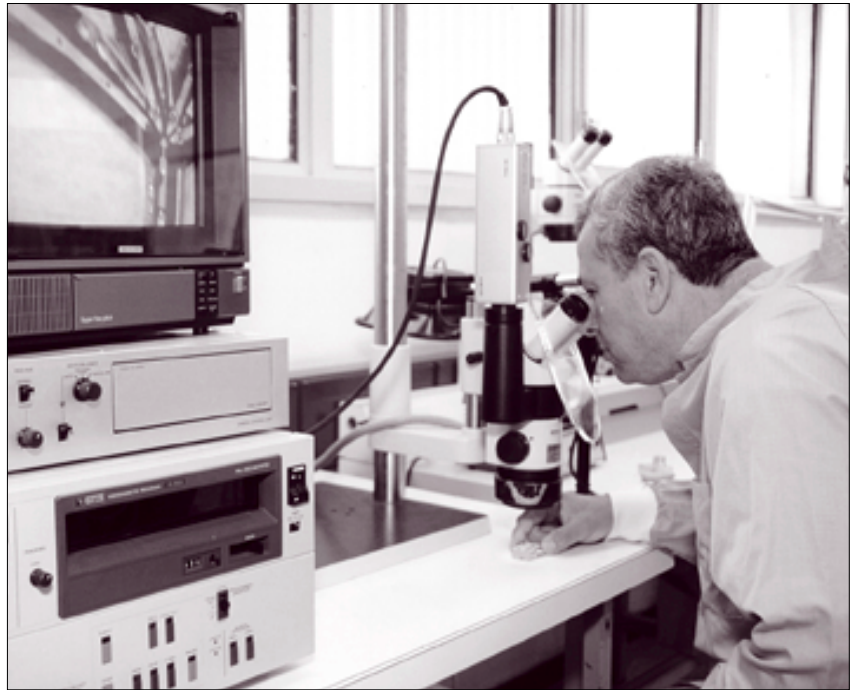

Elisra Defense and Commercial Applications All Across the Globe

Defense applications are known for their demanding and stringent requirements and Elisra systems have been proven with thousands of hours in the field. Based on our wealth-of military expertise, combat know-how and adaptability, we also provide creative and competitive solutions for commercial applications. With more than a \$46 million turnover, our advanced technologies have been brought to all corners of the world. Our growing client list includes such notable companies as Motorola, Lockheed Martin, BAE Systems, Daimler-Benz Aerospace, IBM, British Telecom, Deutsche Telekom, and many others.

Modern Facilities and Experienced Staff

Our modern plant occupies more than 22,000 square meters of floor space and is located in suburb of Tel-Aviv, within close proximity to Ben Gurion International Airport. Over the years, we have built up a team of experienced and committed staff employing a highly skilled group of more than 270 microwave engineers, technicians, production workers and marketing specialists. They support all projects from their inception through to completion with ongoing after-sales support. Our production site also comprises state-of-the-art equipment and facilities including "cleanrooms", laser processing machines, and automatic "pick-and-place" equipment. The majority of the company's engineers and technicians are reserve officers and soldiers in the Israeli Defense Forces, adding unmatched knowledge of the battlefield experience. It is this



very blend of technological expertise and in-depth understanding from real-life scenarios that is the foundation of our position of distinction in the Industry.

Comprehensive Quality Assurance and Reliability Program

Elisra is synonymous and reliability and quality by virtue of the fact that our products are deployed in some of the most innovative and sophisticated military and commercial systems. This is achieved by careful in-house planning and design, accurate workmanship standards, controlled procedures and rigorous inspections. All phases of our activities from design through to production are carefully monitored by the independently managed quality assurance department personnel. Elisra's facilities and products are ISO-9001 certified, reflecting internationally recognized standards. Elisra's quality assurance program is based on the following military specifications and standards: MIL-E-4158, MIL-E-5400, MIL-E-16400, MIL-M-38510, MIL-STD-202, MIL-STD-454.



In-house capabilities at all levels of project design, development, production, testing and system integration assure outstanding accuracy and quick time-to-market.

All systems and components are inspected to conform to precise requirements and specifications.

Comprehensive testing includes simulation of some of the most extreme conditions possible via the use of special vibration, temperature and humidity chambers.

On-Going Customer Support and Satisfaction

The proven reliability of our products is a reflection of the continuous communication we have with our customers.

To ensure that our customers' requirements are met, constant dialogue and feedback are attained at every stage of the development process. Once systems are installed, we provide on-going documentation, training and support to ensure that our clients become expert and successful users of the technology.

Wide Product Portfolio

In this catalog you will find a brief overview of microwave amplifiers lines offered by Elisra Microwave Division.

For more details about our other microwave products, please visit our web site:

www.mw-elisra.com

Control Devices

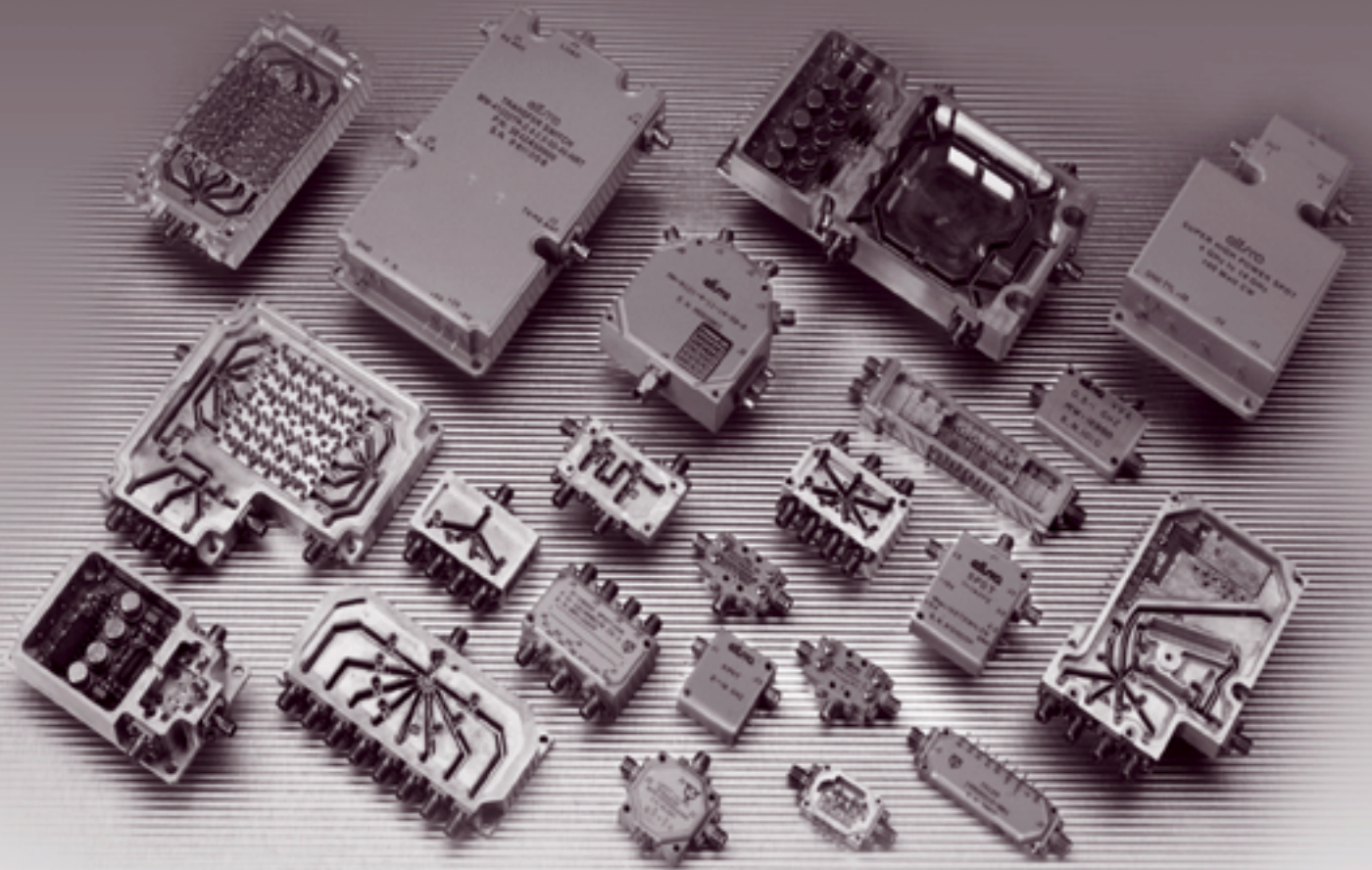

[Index](#)



Microwave Switches

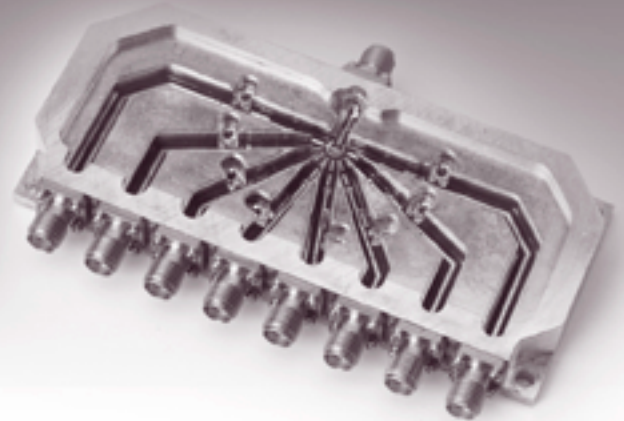

- ▶ **SPST To SP16T Switches**
 - High Frequency Switches**
 - Low-Frequency Switches**
- ▶ **Drop-in Switches**
- ▶ **Transfer Switches**
- ▶ **High Power Switches**

GENERAL INFORMATION

Insertion Loss

The difference in power, measured in dB, between input level and output level when the unit is at low loss condition and all other throws are off.

Isolation

The in power, measured in dB, between input level and output level when the unit is at high loss condition. Isolation of the off throws in multithrow switches is measured with another throw at low loss condition and is properly terminated.

VSWR

The ratio between the reflected signal and the incident signal.

Power Handling Capability

The maximum CW power to which the unit can be subjected without possible permanent damage. This rating is based on the assumption that a 50 ohm source and load are used and that the control voltages and temperature range are within the specified limits.

Switching Time

The time required for the device to attain 90% of the final RF signal referenced to the 50% level of the command logic (see Figure 1).

Recommended Driver Waveforms

The time required for PIN diodes to change state is a function of drive current, driving impedance and parameters of the diodes. To achieve specified switching speed (in units without a driver), current spikes are necessary (see Figure 2).

Switching Transients

One of the consequences of fast switching are the switching transients which appear at the RF ports.



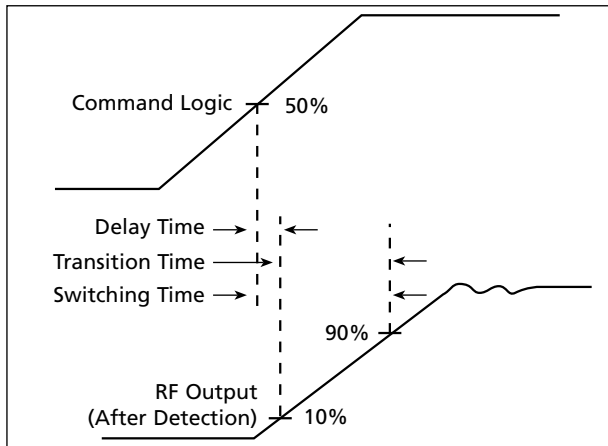

Figure 1. Switching Time Curves

The transients are due to the DC shifts which occur internally in the switch during switching. Transients can cause problems because their spectral content can cause false signals to occur during switching. The problem is particularly serious when the spectral content is inside the RF band of the switch. The frequency of the transient spectral content is a function of the speed of the switch. Faster switching produces transient energy at higher frequencies. The amplitude of the transients is higher for faster switching speeds and for switches designed for lower frequencies. To decrease this effect, Elisra uses built-in, small size, low loss, high pass filters. Another way to decrease this effect is by using slower switching speed switches.

Video Leakage Measurements

Transients are specified in several ways. One approach is to specify the maximum allowable amplitude of the transient found at each of the RF ports. Alternately, when the majority of the spectral content is outside the switch RF band, transient amplitude can be specified in-band only. This can be measured by filtering off the out-of-band transient energy. An additional method specifies the spectral content, in dBm, in the RF band of interest.

Input Drive Requirements*

Speed	"0" Logic	"1" Logic
Low speed	0.8V max. 1.6 mA	2.5V min. 0.04 mA
High speed	0.8V max. 5.0 mA	2.5V min. 4.0 mA

* Provided for high speed modules.

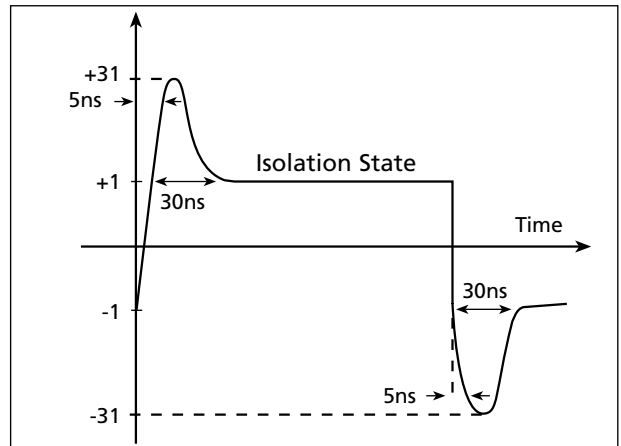

Figure 2. Recommended Driver Waveform

The measuring technique is described in the following set-up schematic (see Figure 3).

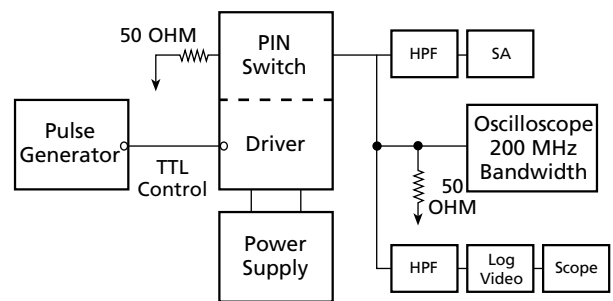

Figure 3. Video Leakage Measuring Technique

Test Conditions

Switching Rate: Maximum switching rate specified

Pulse Width: 50% of time period

RF Input: None

Power Supplies: ON

RF Ports: All RF ports are 50 ohms terminated

Definition: The video leakage measured by the set-up is defined by the maximum spike that occurs (mV peak to peak)

NOTE: 50 ohm terminations should be connected to all RF ports.

SPST PIN Diode Switches

HIGH FREQUENCY

Series MW 121T

- ▶ Solid State
- ▶ Frequency Band 0.5 to 18 GHz
- ▶ Low Insertion Loss
- ▶ High Isolation
- ▶ Integral TTL Driver
- ▶ Hermetically Sealed



GENERAL INFORMATION

This series of SPST switches is designed to give excellent performance for a wide range of military system applications in the 0.5 GHz to 18 GHz frequency range.

GENERAL SPECIFICATIONS

Power Handling Capability	100 mW
Operating Temperature Range	-55°C to +105°C
Storage Temperature Range	-65°C to +125°C
Reflective Switching Speed	15 ns typical
Non-Reflective Switching Speed	25 ns typical

OPTIONS

- ▶ Low Video Leakage
- ▶ Switches Without Drivers
- ▶ Another Frequency Band
- ▶ Lower Insertion Loss Can Be Provided

HOW TO ORDER

See the variety of switches on the next page, and follow the example below:

$$\frac{\text{MW 121 T28}}{1} - \frac{\text{H}}{2} - \frac{\text{H}}{3} - \frac{\text{0}}{4} - \frac{\text{A}}{5} - \frac{\text{C3}}{6}$$

$$= \text{MW 121T28HH0AC3}$$

LEGEND

1. Basic model number for an SPST switch
2. Isolation (Reflective or Non-Reflective)
 - H - High, 60 dB L - Low, 40 dB
3. Switching Speed

	Reflective	Non-Reflective
H - High	15 ns	25 ns
L - Low	100 ns	150 ns
4. TTL Control Logic
 - 0 - Logic "0" Low Loss
 Logic "1" Isolation
 - 1 - Logic "0" Isolation
 Logic "1" Low Loss
5. Power Supply
 - a. Voltage
 - A - +5V -12V
 - B - +5V -15V
 - C - +12V -12V
 - D - +15V -15V
 - b. Current
 - High Speed +40 mA (+V)
 - 25 mA (-V)
 - Low Speed +100 mA (+V)
 - 50 mA (-V)
6. Case type



SPECIFICATIONS

MW 121T High Isolation/High Speed/Low Speed Switches

High Frequency Reflective Switches

Model Number	Frequency (GHz)																	
	0.5 to 1			1 to 2			2 to 4			4 to 8			8 to 12			12 to 18		
	IL max (dB)	Isolation min (dB)	VSWR max	IL max (dB)	Isolation min (dB)	VSWR max	IL max (dB)	Isolation min (dB)	VSWR max	IL max (dB)	Isolation min (dB)	VSWR max	IL max (dB)	Isolation min (dB)	VSWR max	IL max (dB)	Isolation min (dB)	VSWR max
MW 121T51	0.8	60	1.8															
MW 121T12				1	60	1.8												
MW 121T24							1.3	60	1.8									
MW 121T48										1.5	60	2.0						
MW 121T82													1.8	60	2.0			
MW 121T18																2	60	2.0
MW 121T52	0.8	60	1.8	1	60	1.8												
MW 121T08							1.3	60	1.8	1.5	60	2.0						
MW 121T88													1.8	60	2.0	2	60	2.0
MW 121T28							1.3	60	1.8	1.5	60	2.0	1.8	60	2.0	2	60	2.0

High Frequency Non-Reflective Switches

Model Number	Frequency (GHz)																	
	0.5 to 1			1 to 2			2 to 4			4 to 8			8 to 12			12 to 18		
	IL max (dB)	Isolation min (dB)	VSWR max	IL max (dB)	Isolation min (dB)	VSWR max	IL max (dB)	Isolation min (dB)	VSWR max	IL max (dB)	Isolation min (dB)	VSWR max	IL max (dB)	Isolation min (dB)	VSWR max	IL max (dB)	Isolation min (dB)	VSWR max
MW 121T51	1	60	1.8															
MW 121T12				1.4	60	1.8												
MW 121T24							1.7	60	1.8									
MW 121T48										1.9	60	2.0						
MW 121T82													2.2	60	2.0			
MW 121T18																2.6	60	2.0
MW 121T52	1	60	1.8	1.4	60	1.8												
MW 121T08							1.7	60	1.8	1.9	60	2.0						
MW 121T88													2.2	60	2.0	2.6	60	2.0
MW 121T28							1.7	60	1.8	1.9	60	2.0	2.2	60	2.0	2.6	60	2.0

Note: Outline drawings of cases are depicted on pages following these tables.



Outline Drawings

All dimensions are in inches and (mm). Drawings are in first angle projection.

HIGH ISOLATION/HIGH SPEED SWITCHES

CASE C3

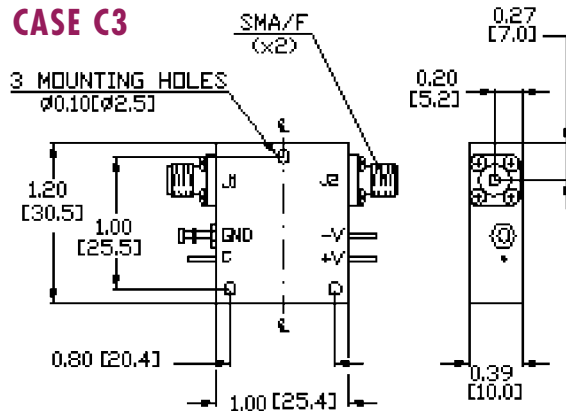

CASE C5

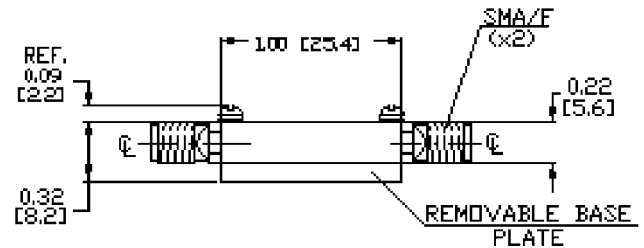

CASE C4

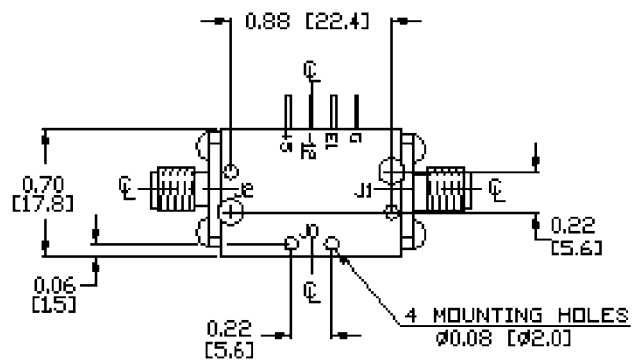
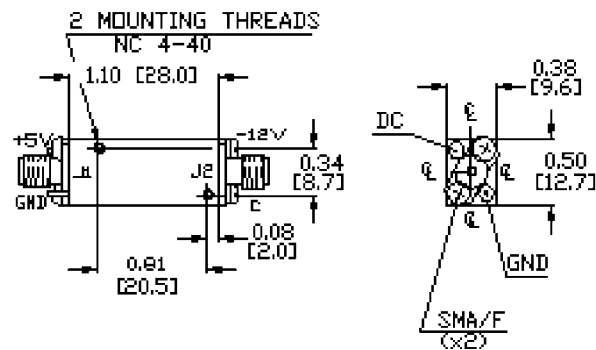

HIGH ISOLATION/LOW SPEED SWITCHES

CASE C5

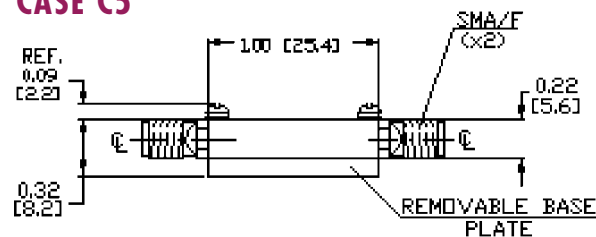

CASE C1

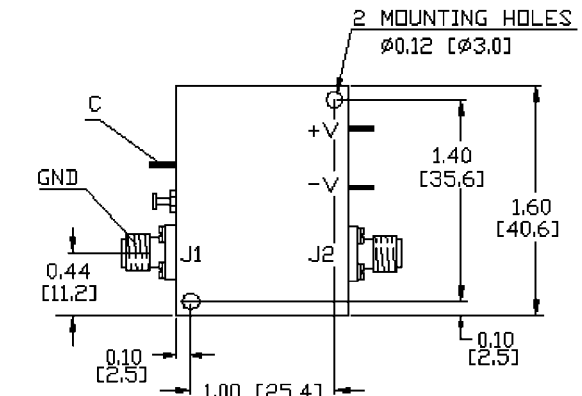
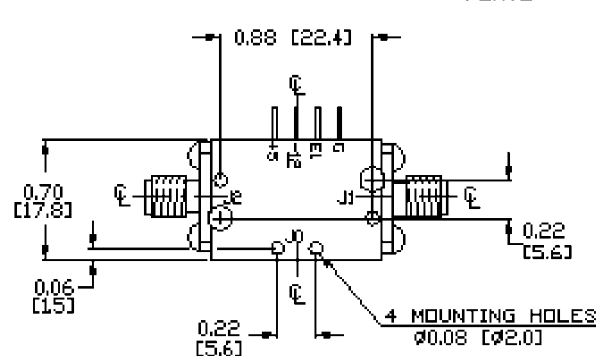
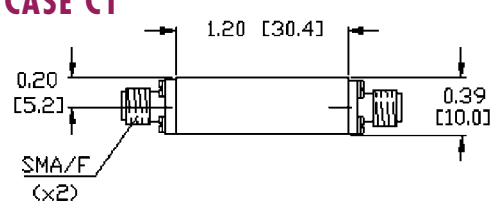

SP2T PIN Diode Switches

HIGH FREQUENCY

Series MW 122T

- ▶ Solid State
- ▶ Frequency Band 0.5 to 18 GHz
- ▶ Low Insertion Loss
- ▶ High Isolation
- ▶ Integral TTL Driver
- ▶ Hermetically Sealed

GENERAL INFORMATION

This series of SP2T switches is designed to give excellent performance for a wide range of military system applications in the 0.5 GHz to 18 GHz frequency range.

GENERAL SPECIFICATIONS

Power Handling Capability	100 mW
Operating Temperature Range	-55°C to +105°C
Storage Temperature Range	-65°C to +125°C
Reflective Switching Speed	25 ns typical
Non-Reflective Switching Speed	25 ns typical

OPTIONS

- ▶ Low Video Leakage
- ▶ Switches Without Drivers
- ▶ Another Frequency Band
- ▶ Lower Insertion Loss Can Be Provided

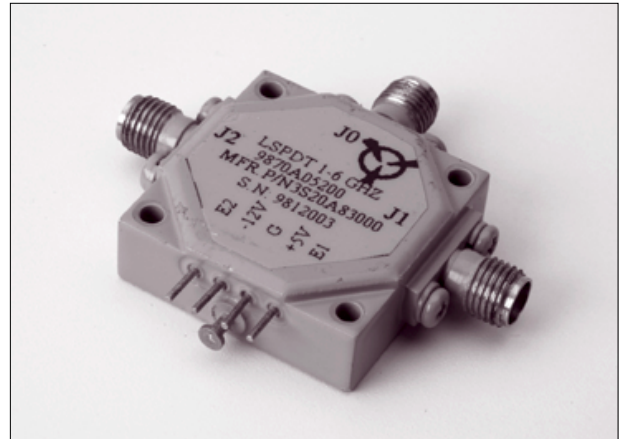

HOW TO ORDER

See the variety of switches on the next page, and follow the example below:

$$\frac{\text{MW 122 T28}}{1} - \frac{\text{H}}{2} - \frac{\text{H}}{3} - \frac{\text{0}}{4} - \frac{\text{A}}{5} - \frac{\text{G3}}{6}$$

= MW 122T28HH0AG3

LEGEND

1. Basic model number for an SP2T switch
2. Isolation (Reflective or Non-Reflective)

H - High, 60 dB	L - Low, 40 dB
-----------------	----------------
3. Switching Speed

	Reflective	Non-Reflective
H - High	25 ns	25 ns
L - Low	100 ns	150 ns
4. TTL Control Logic

0 - Logic "0" Low Loss	Logic "1" Isolation
1 - Logic "0" Isolation	Logic "1" Low Loss
5. Power Supply
 - a. Voltage

A - +5V	-12V
B - +5V	-15V
C - +12V	-12V
D - +15V	-15V
 - b. Current

High Speed	+80 mA (+V)	- 25 mA (-V)
Low Speed	+125 mA (+V)	- 50 mA (-V)
6. Case type



SPECIFICATIONS

MW 122T High Isolation/High Speed/Low Speed Switches

High Frequency Reflective Switches

Model Number	Frequency (GHz)																	
	0.5 to 1			1 to 2			2 to 4			4 to 8			8 to 12			12 to 18		
	IL max (dB)	Isolation min (dB)	VSWR max	IL max (dB)	Isolation min (dB)	VSWR max	IL max (dB)	Isolation min (dB)	VSWR max	IL max (dB)	Isolation min (dB)	VSWR max	IL max (dB)	Isolation min (dB)	VSWR max	IL max (dB)	Isolation min (dB)	VSWR max
MW 122T51	1	60	1.8															
MW 122T12				1.2	60	1.8												
MW 122T24							1.5	60	1.8									
MW 122T48										1.8	60	2.0						
MW 122T82													2	55	2.0			
MW 122T18																2.4	60	2.0
MW 122T52	1	60	1.8	1.2	60	1.8												
MW 122T08							1.5	60	1.8	1.8	60	2.0						
MW 122T88													2	55	2.0	2.4	60	2.0
MW 122T28							1.5	60	1.8	1.8	60	2.0	2	55	2.0	2.4	60	2.0

High Frequency Non-Reflective Switches

Model Number	Frequency (GHz)																	
	0.5 to 1			1 to 2			2 to 4			4 to 8			8 to 12			12 to 18		
	IL max (dB)	Isolation min (dB)	VSWR max	IL max (dB)	Isolation min (dB)	VSWR max	IL max (dB)	Isolation min (dB)	VSWR max	IL max (dB)	Isolation min (dB)	VSWR max	IL max (dB)	Isolation min (dB)	VSWR max	IL max (dB)	Isolation min (dB)	VSWR max
MW 122TN51	1.4	60	1.8															
MW 122TN12				1.6	60	1.8												
MW 122TN24							1.9	60	1.8									
MW 122TN48										2.2	60	2.0						
MW 122TN82													2.4	55	2.0			
MW 122TN18																2.8	55	2.0
MW 122TN52	1.4	60	1.8	1.6	60	1.8												
MW 122TN08							1.9	60	1.8	2.2	60	2.0						
MW 122TN88													2.4	55	2.0	2.8	55	2.0
MW 122TN28							1.9	60	1.8	2.2	60	2.0	2.4	55	2.0	2.8	55	2.0

Note: Outline drawings of cases are depicted on pages following these tables.



Outline Drawings

All dimensions are in inches and (mm). Drawings are in first angle projection.

HIGH ISOLATION/HIGH SPEED SWITCHES

CASE V3

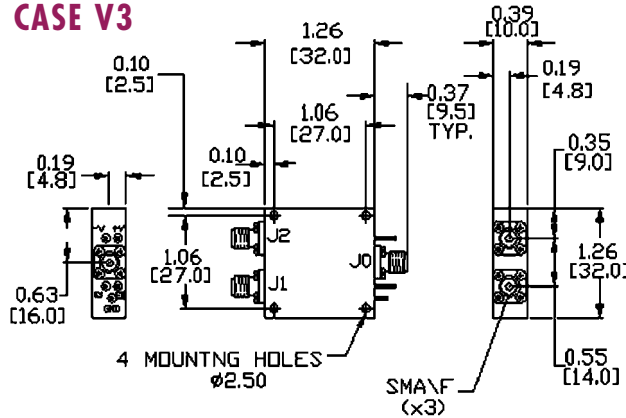

CASE G5

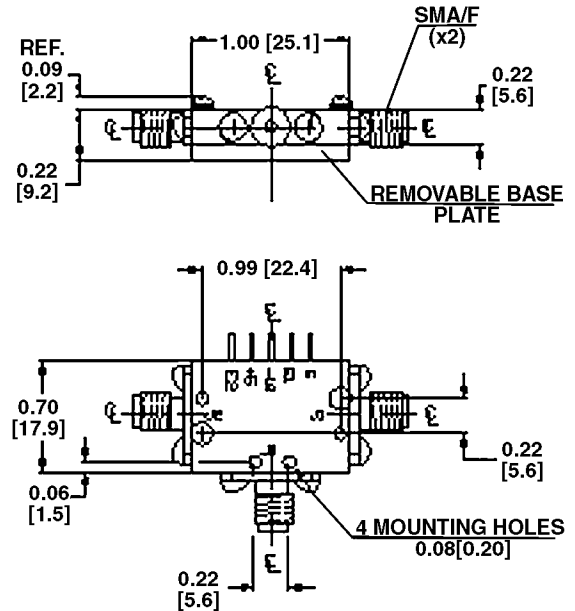

CASE O

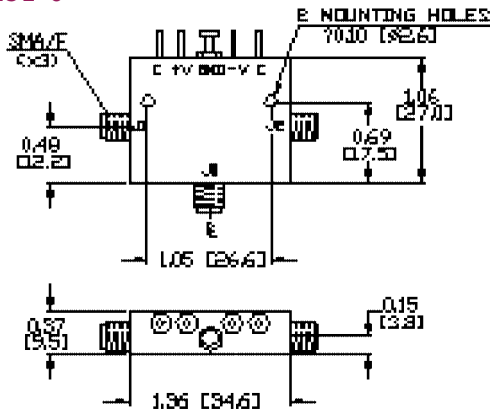

HIGH ISOLATION/LOW SPEED SWITCHES

CASE G3

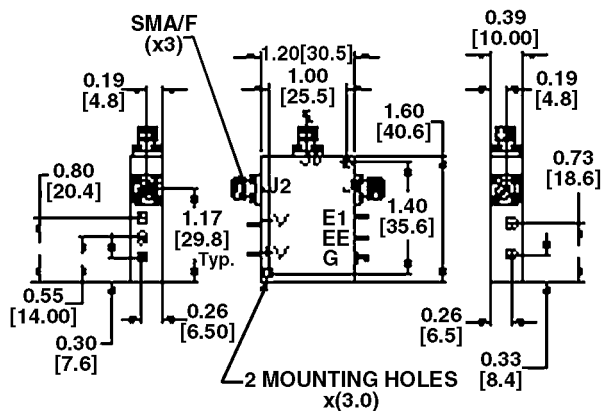

CASE G5

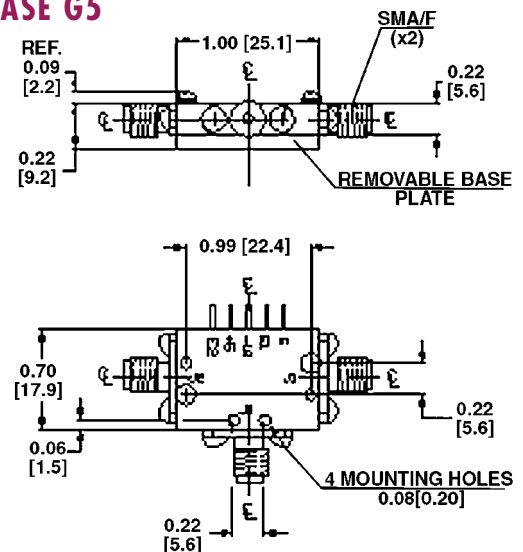

SP3T PIN Diode Switches

HIGH FREQUENCY

Series MW 123T

- ▶ Solid State
- ▶ Frequency Band 0.5 to 18 GHz
- ▶ Low Insertion Loss
- ▶ High Isolation
- ▶ Integral TTL Driver
- ▶ Hermetically Sealed

GENERAL INFORMATION

This series of SPST switches is designed to give excellent performance for a wide range of military system applications in the 0.5 GHz to 18 GHz frequency range.

GENERAL SPECIFICATIONS

Power Handling Capability	100 mW
Operating Temperature Range	-55°C to +105°C
Storage Temperature Range	-65°C to +125°C
Reflective Switching Speed	25 ns typical
Non-Reflective Switching Speed	25 ns typical

OPTIONS

- ▶ Low video Leakage
- ▶ Switches Without Drivers
- ▶ Another Frequency Band
- ▶ Lower Insertion Loss Can Be Provided

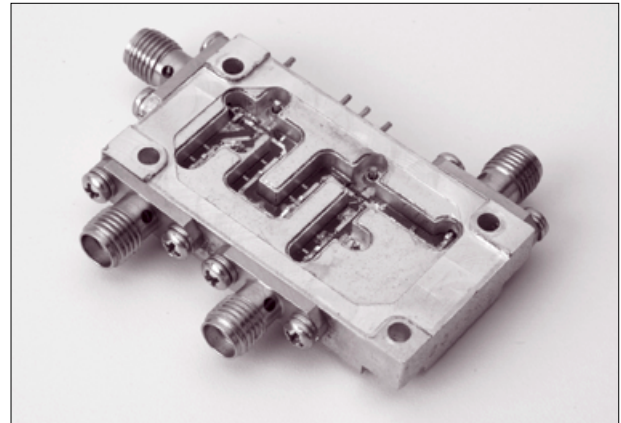

HOW TO ORDER

See the variety of switches on the next page, and follow the example below:

MW 123 T28 - H - H - 0 - A - R4
1 - 2 - 3 - 4 - 5 - 6

= MW 123T28HH0AR4

LEGEND

1. Basic model number for an SP3T switch
2. Isolation (Reflective or Non-Reflective)
H - High, 60 dB L - Low, 40 dB
3. Switching Speed
Reflective Non-Reflective
H - High 20 ns 25 ns
L - Low 100 ns 150 ns
4. TTL Control Logic
0 - Logic "0" Low Loss
 Logic "1" Isolation
1 - Logic "0" Isolation
 Logic "1" Low Loss
5. Power Supply
 - a. Voltage
A - +5V -12V
B - +5V -15V
C - +12V -12V
D - +15V -15V
 - b. Current
High Speed +100 mA (+V)
 - 40 mA (-V)
Low Speed +130 mA (+V)
 - 90 mA (-V)
6. Case type



SPECIFICATIONS

MW 123T High Isolation/High Speed/Low Speed Switches

High Frequency Reflective Switches

Model Number	Frequency (GHz)																	
	0.5 to 1			1 to 2			2 to 4			4 to 8			8 to 12			12 to 18		
	IL max (dB)	Isolation min (dB)	VSWR max	IL max (dB)	Isolation min (dB)	VSWR max	IL max (dB)	Isolation min (dB)	VSWR max	IL max (dB)	Isolation min (dB)	VSWR max	IL max (dB)	Isolation min (dB)	VSWR max	IL max (dB)	Isolation min (dB)	VSWR max
MW 123T51	1.2	60	1.8															
MW 123T12				1.5	60	1.8												
MW 123T24							1.6	60	1.8									
MW 123T48										2	60	2.0						
MW 123T82													2.4	60	2.0			
MW 123T18																2.8	60	2.0
MW 123T52	1.2	60	1.8	1.5	60	1.8												
MW 123T08							1.6	60	1.8	2	60	2.0						
MW 123T88													2.4	60	2.0	2.8	60	2.0
MW 123T28							1.6	60	1.8	2	60	2.0	2.4	60	2.0	2.8	60	2.0

High Frequency Non-Reflective Switches

Model Number	Frequency (GHz)																	
	0.5 to 1			1 to 2			2 to 4			4 to 8			8 to 12			12 to 18		
	IL max (dB)	Isolation min (dB)	VSWR max	IL max (dB)	Isolation min (dB)	VSWR max	IL max (dB)	Isolation min (dB)	VSWR max	IL max (dB)	Isolation min (dB)	VSWR max	IL max (dB)	Isolation min (dB)	VSWR max	IL max (dB)	Isolation min (dB)	VSWR max
MW 123TN51	1.6	60	2.0															
MW 123TN12				1.9	60	2.0												
MW 123TN24							2	60	2.0									
MW 123TN48										2.4	60	2.0						
MW 123TN82													2.8	60	2.0			
MW 123TN18																3.2	60	2.0
MW 123TN52	1.6	60	2.0	1.9	60	2.0												
MW 123TN08							2	60	2.0	2.4	60	2.0						
MW 123TN88													2.8	60	2.0	3.2	60	2.0
MW 123TN28							2	60	2.0	2.4	60	2.0	2.8	60	2.0	3.2	60	2.0

Note: Outline drawings of cases are depicted on pages following these tables.



Outline Drawings

All dimensions are in inches and (mm). Drawings are in first angle projection.

HIGH ISOLATION/HIGH SPEED SWITCHES

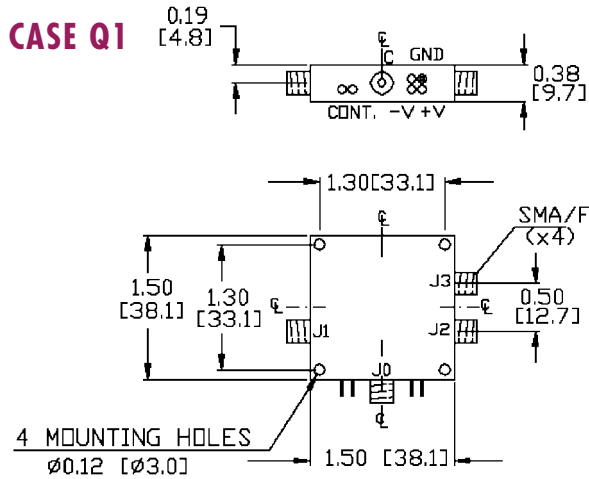

CASE R1

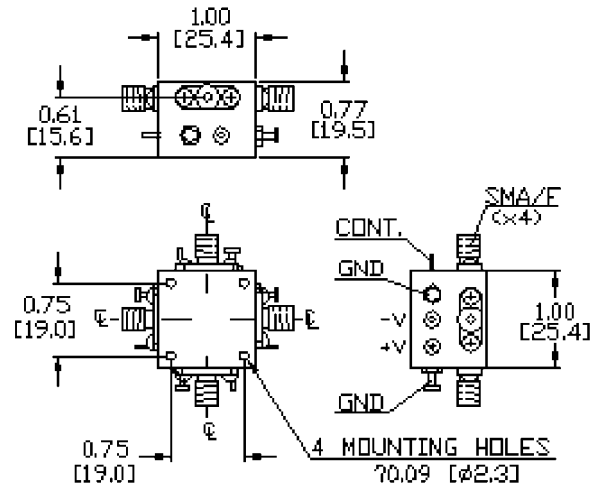

CASE R4

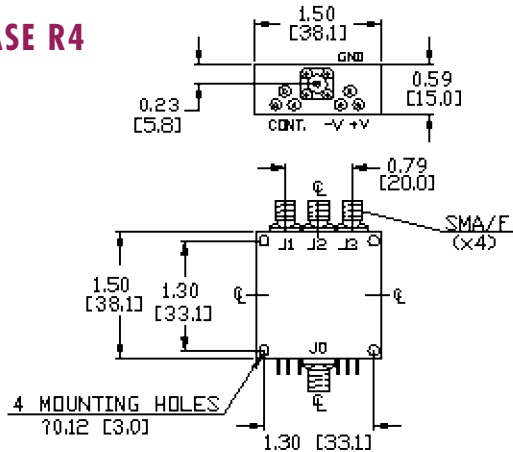

HIGH ISOLATION/LOW SPEED SWITCHES

CASE R3

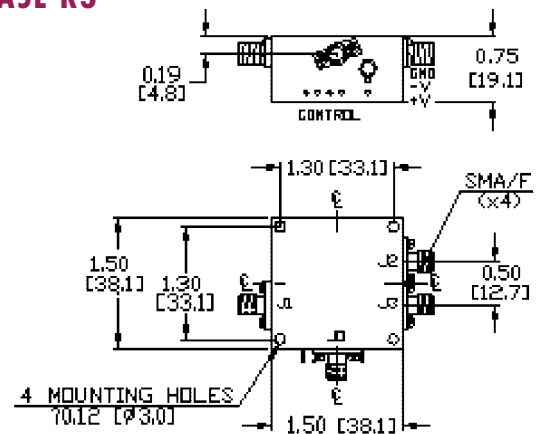

CASE R5

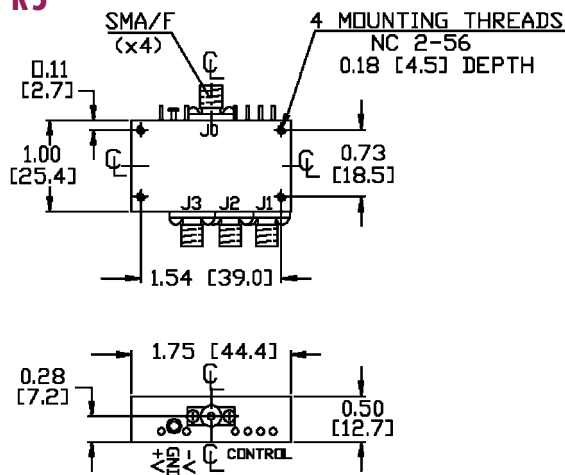

SP4T PIN Diode Switches

HIGH FREQUENCY

Series MW 124T

- ▶ Solid State
- ▶ Frequency Band 0.5 to 18 GHz
- ▶ Low Insertion Loss
- ▶ High Isolation
- ▶ Integral TTL Driver
- ▶ Hermetically Sealed

GENERAL INFORMATION

This series of SP4T switches is designed to give excellent performance for a wide range of military system applications in the 0.5 GHz to 18 GHz frequency range.

GENERAL SPECIFICATIONS

Power Handling Capability	100 mW
Operating Temperature Range	-55°C to +105°C
Storage Temperature Range	-65°C to +125°C
Reflective Switching Speed	25 ns typical
Non-Reflective Switching Speed	25 ns typical

OPTIONS

- ▶ Low Video Leakage
- ▶ Switches Without Drivers
- ▶ Another Frequency Band
- ▶ Lower Insertion Loss Can Be Provided

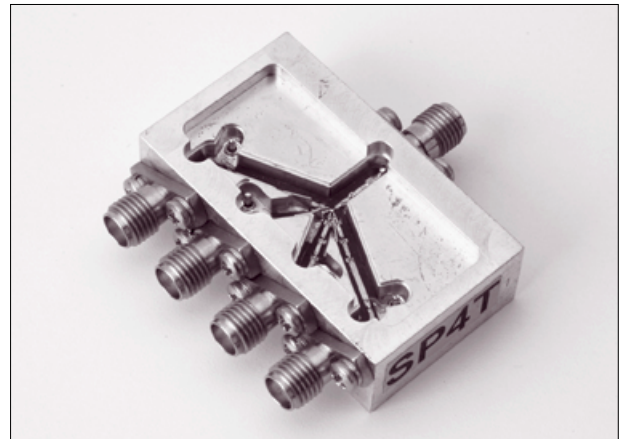

HOW TO ORDER

See the variety of switches on the next page, and follow the example below:

MW 124 T28 - H - H - 0 - A - Q2
1 2 3 4 5 6

= MW 124T28HH0AQ2

LEGEND

1. Basic model number for an SP4T switch
2. Isolation (Reflective or Non-Reflective)
H - High, 60 dB L - Low, 40 dB
3. Switching Speed
Reflective Non-Reflective
H - High 20 ns 25 ns
L - Low 100 ns 150 ns
4. TTL Control Logic
0 - Logic "0" Low Loss
Logic "1" Isolation
1 - Logic "0" Isolation
Logic "1" Low Loss
5. Power Supply
 - a. Voltage
A - +5V -12V
B - +5V -15V
C - +12V -12V
D - +15V -15V
 - b. Current
High Speed +140 mA (+V)
- 40 mA (-V)
Low Speed +160 mA (+V)
- 60 mA (-V)
6. Case type



SPECIFICATIONS

MW 124T High Isolation/High Speed/Low Speed Switches

High Frequency Reflective Switches

Model Number	Frequency (GHz)																	
	0.5 to 1			1 to 2			2 to 4			4 to 8			8 to 12			12 to 18		
	IL max (dB)	Isolation min (dB)	VSWR max	IL max (dB)	Isolation min (dB)	VSWR max	IL max (dB)	Isolation min (dB)	VSWR max	IL max (dB)	Isolation min (dB)	VSWR max	IL max (dB)	Isolation min (dB)	VSWR max	IL max (dB)	Isolation min (dB)	VSWR max
MW 124T51	1.2	60	1.8															
MW 124T12				1.3	60	2.0												
MW 124T24							1.5	60	2.0									
MW 124T48									1.8	60	2.0							
MW 124T82												2.4	60	2.0				
MW 124T18															3.0	60	2.0	
MW 124T52	1.2	60	2.0	1.3	60	2.0												
MW 124T08							1.5	60	2.0	1.8	60	2.0						
MW 124T88													2.4	60	2.0	2.0	60	2.0
MW 124T28							1.5	60	2.0	1.8	60	2.0	2.4	60	2.0	3.0	60	2.0

High Frequency Non-Reflective Switches

Model Number	Frequency (GHz)																	
	0.5 to 1			1 to 2			2 to 4			4 to 8			8 to 12			12 to 18		
	IL max (dB)	Isolation min (dB)	VSWR max	IL max (dB)	Isolation min (dB)	VSWR max	IL max (dB)	Isolation min (dB)	VSWR max	IL max (dB)	Isolation min (dB)	VSWR max	IL max (dB)	Isolation min (dB)	VSWR max	IL max (dB)	Isolation min (dB)	VSWR max
MW 124TN51	1.6	60	2.0															
MW 124TN12				1.8	60	2.0												
MW 124TN24							2.0	60	2.0									
MW 124TN48										2.2	60	2.0						
MW 124TN82													2.6	60	2.0			
MW 124TN18																3.2	60	2.0
MW 124TN52	1.6	60	2.0	1.8	60	2.0												
MW 124TN08							2.0	60	2.0	2.2	60	2.0						
MW 124TN88													2.6	60	2.0	3.2	60	2.0
MW 124TN28							2.0	60	2.0	2.2	60	2.6	60	2.0	3.2	2.0	60	2.0

Note: Outline drawings of cases are depicted on pages following these tables. Termination at the Input Port.



Outline Drawings

All dimensions are in inches and (mm). Drawings are in first angle projection.

HIGH ISOLATION/HIGH SPEED SWITCHES

CASE Q6

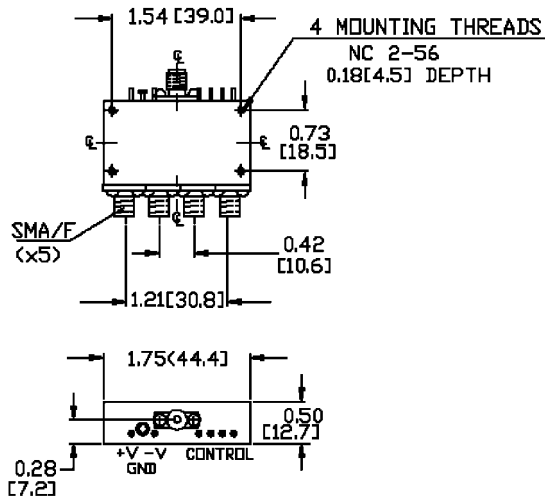

CASE Q7

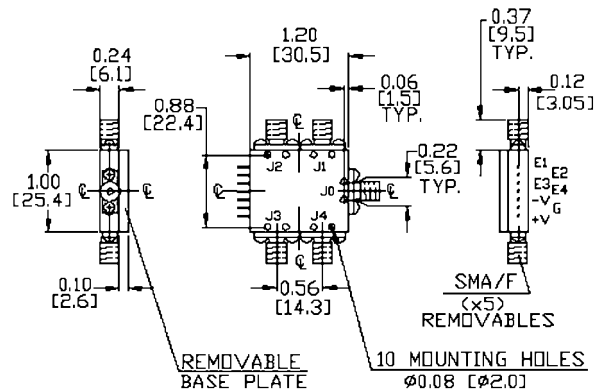

HIGH ISOLATION/LOW SPEED SWITCHES

CASE Q31

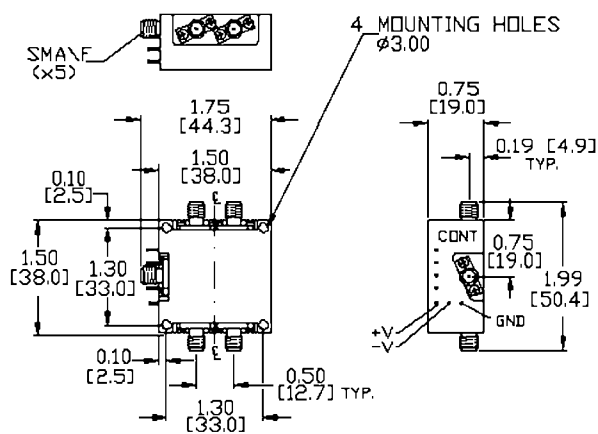

CASE Q5

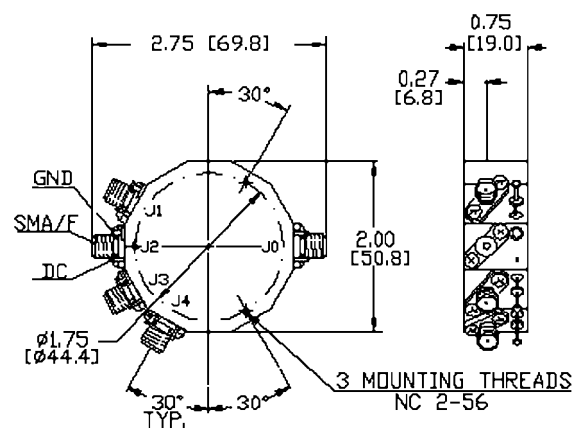

SP5T PIN Diode Switches

HIGH FREQUENCY

Series MW 125T

- ▶ Solid State
- ▶ Frequency Band 0.5 to 18 GHz
- ▶ Low Insertion Loss
- ▶ High Isolation
- ▶ Integral TTL Driver
- ▶ Hermetically Sealed

GENERAL INFORMATION

This series of SP5T switches is designed to give excellent performance for a wide range of military system applications in the 0.5 GHz to 18 GHz frequency range.

GENERAL SPECIFICATIONS

Power Handling Capability	100 mW
Operating Temperature Range	-55°C to +105°C
Storage Temperature Range	-65°C to +125°C
Reflective Switching Speed	30ns typical
Non-Reflective Switching Speed	30 ns typical

OPTIONS

- ▶ Low Video Leakage
- ▶ Switches Without Drivers
- ▶ Another Frequency Band
- ▶ Lower Insertion Loss Can Be Provided

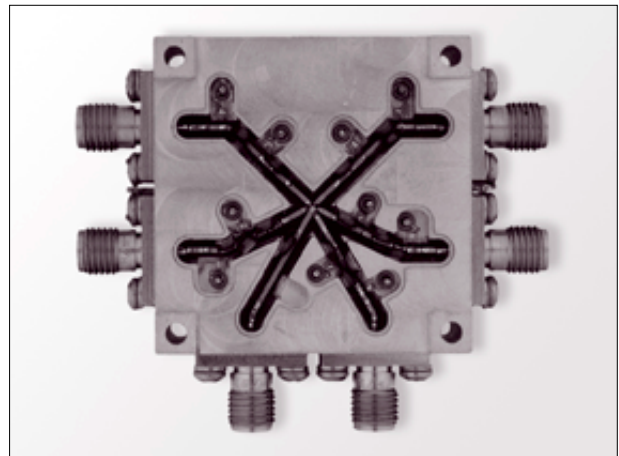

HOW TO ORDER

See the variety of switches on the next page, and follow the example below:

MW 125 T28 - H - H - 0 - A - T
1 - 2 - 3 - 4 - 5 - 6

LEGEND

1. Basic model number for an SP5T switch
2. Isolation (Reflective or Non-Reflective)
H - High, 60 dB L - Low, 40 dB
3. Switching Speed
Reflective Non-Reflective
H - High 15 ns 25 ns
L - Low 100 ns 150 ns
4. TTL Control Logic
0 - Logic "0" Low Loss
Logic "1" Isolation
1 - Logic "0" Isolation
Logic "1" Low Loss
5. Power Supply
 - a. Voltage
A - +5V -12V
B - +5V -15V
C - +12V -12V
D - +15V -15V
 - b. Current
High Speed +170 mA (+V)
- 40 mA (-V)
Low Speed +170 mA (+V)
- 140 mA (-V)
6. Case type



SPECIFICATIONS

MW 125T High Isolation/High Speed/Low Speed Switches

High Frequency Reflective Switches

Model Number	Frequency (GHz)																	
	0.5 to 1			1 to 2			2 to 4			4 to 8			8 to 12			12 to 18		
	IL max (dB)	Isolation min (dB)	VSWR max	IL max (dB)	Isolation min (dB)	VSWR max	IL max (dB)	Isolation min (dB)	VSWR max	IL max (dB)	Isolation min (dB)	VSWR max	IL max (dB)	Isolation min (dB)	VSWR max	IL max (dB)	Isolation min (dB)	VSWR max
MW 125T51	1.4	60	2.0															
MW 125T12				1.5	60	2.0												
MW 125T24							1.8	60	2.0									
MW 125T48										2.2	60	2.0						
MW 125T82													2.8	60	2.0			
MW 125T18																3.5	60	2.0
MW 125T52	1.4	60	2.0	1.5	60	2.0												
MW 125T08							1.8	60	2.0	2.2	60	2.0						
MW 125T88													2.8	60	2.0	3.5	60	2.0
MW 125T28							1.8	60	2.0	2.2	60	2.0	2.8	60	2.0	3.5	60	2.0

High Frequency Non-Reflective Switches

Model Number	Frequency (GHz)																	
	0.5 to 1			1 to 2			2 to 4			4 to 8			8 to 12			12 to 18		
	IL max (dB)	Isolation min (dB)	VSWR max	IL max (dB)	Isolation min (dB)	VSWR max	IL max (dB)	Isolation min (dB)	VSWR max	IL max (dB)	Isolation min (dB)	VSWR max	IL max (dB)	Isolation min (dB)	VSWR max	IL max (dB)	Isolation min (dB)	VSWR max
MW 125TN51	1.7	60	2.0															
MW 125TN12				1.8	60	2.0												
MW 125TN24							2.2	60	2.0									
MW 125TN48										2.6	60	2.0						
MW 125TN82													3.0	60	2.0			
MW 125TN18																3.5	60	2.0
MW 125TN52	1.7	60	2.0	1.8	60	2.0												
MW 125TN08							2.2	60	2.0	2.6	60	2.0						
MW 125TN88													3.0	60	2.0	3.5	60	2.0
MW 125TN28							2.2	60	2.0	2.6	60	2.0	3.0	60	2.0	3.5	60	2.0

Note: Outline drawings of cases are depicted on pages following these tables.



Outline Drawings

All dimensions are in inches and (mm). Drawings are in first angle projection.

HIGH ISOLATION/HIGH SPEED SWITCHES

CASE T

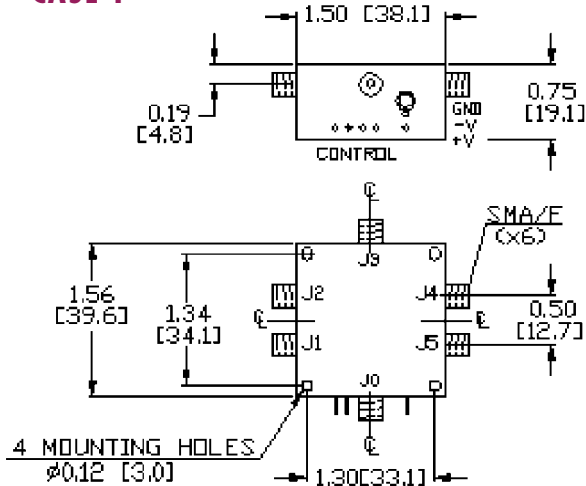

CASE T1

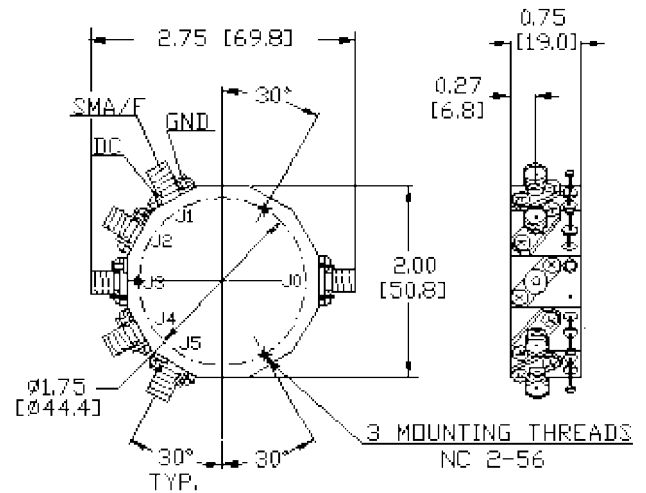

HIGH ISOLATION/LOW SPEED SWITCHES

CASE T1

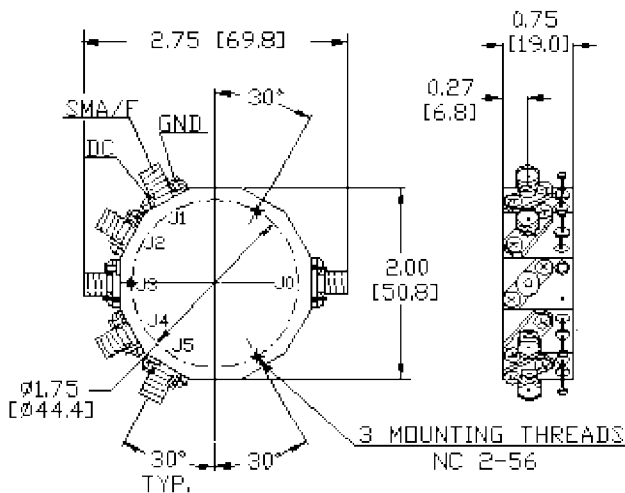

SP6T PIN Diode Switches

HIGH FREQUENCY

Series MW 126T

- ▶ Solid State
- ▶ Frequency Band 0.5 to 18 GHz
- ▶ Low Insertion Loss
- ▶ High Isolation
- ▶ Integral TTL Driver
- ▶ Hermetically Sealed

GENERAL INFORMATION

This series of SP6T switches is designed to give excellent performance for a wide range of military system applications in the 0.5 GHz to 18 GHz frequency range.

GENERAL SPECIFICATIONS

Power Handling Capability	100 mW
Operating Temperature Range	-55°C to +105°C
Storage Temperature Range	-65°C to +125°C
Reflective Switching Speed	30ns typical
Non-Reflective Switching Speed	30 ns typical

OPTIONS

- ▶ Low Video Leakage
- ▶ Switches Without Drivers
- ▶ Another Frequency Band
- ▶ Lower Insertion Loss Can Be Provided

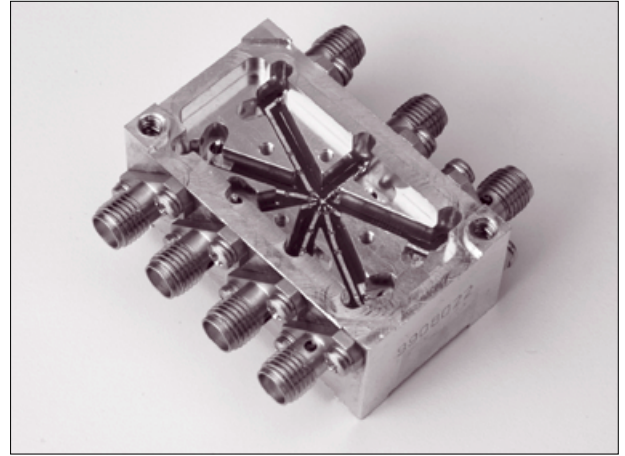

HOW TO ORDER

See the variety of switches on the next page, and follow the example below:

MW 126T28 - $\frac{H}{1}$ - $\frac{H}{2}$ - $\frac{0}{3}$ - $\frac{A}{4}$ - $\frac{X}{5}$ - $\frac{X}{6}$

LEGEND

1. Basic model number for an SP8T switch
2. Isolation (Reflective or Non-Reflective)
H - High, 60 dB L - Low, 40 dB
3. Switching Speed
Reflective Non-Reflective
H - High 20 ns 30 ns
L - Low 100 ns 150 ns
4. TTL Control Logic
0 - Logic "0" Low Loss
 Logic "1" Isolation
1 - Logic "0" Isolation
 Logic "1" Low Loss
5. Power Supply
 - a. Voltage
A - +5V-12V
B - +5V-15V
C - +12V -12V
D - +15V -15V
 - b. Current
High Speed +200 mA (+V)
 - 50 mA (-V)
Low Speed +160 mA (+V)
 - 80 mA (-V)
6. Case type



SPECIFICATIONS

MW 126T High Isolation/High Speed/Low Speed Switches

High Frequency Reflective Switches

Model Number	Frequency (GHz)																	
	0.5 to 1			1 to 2			2 to 4			4 to 8			8 to 12			12 to 18		
	IL max (dB)	Isolation min (dB)	VSWR max	IL max (dB)	Isolation min (dB)	VSWR max	IL max (dB)	Isolation min (dB)	VSWR max	IL max (dB)	Isolation min (dB)	VSWR max	IL max (dB)	Isolation min (dB)	VSWR max	IL max (dB)	Isolation min (dB)	VSWR max
MW 126T51	1.3	60	2.0															
MW 126T12				1.5	60	2.0												
MW 126T24							1.7	60	2.0									
MW 126T48										2.4	60	2.0						
MW 126T82													2.8	60	2.0			
MW 126T18																3.5	60	2.0
MW 126T52	1.3	60	2.0	1.5	60	2.0												
MW 126T08							1.7	60	2.0	2.4	60	2.0						
MW 126T88													2.8	60	2.0	3.5	60	2.0
MW 126T28							1.7	60	2.0	2.4	60	2.0	2.8	60	2.0	3.5	60	2.0

High Frequency Non-Reflective Switches

Model Number	Frequency (GHz)																	
	0.5 to 1			1 to 2			2 to 4			4 to 8			8 to 12			12 to 18		
	IL max (dB)	Isolation min (dB)	VSWR max	IL max (dB)	Isolation min (dB)	VSWR max	IL max (dB)	Isolation min (dB)	VSWR max	IL max (dB)	Isolation min (dB)	VSWR max	IL max (dB)	Isolation min (dB)	VSWR max	IL max (dB)	Isolation min (dB)	VSWR max
MW 126TN51	1.6	60	2.0															
MW 126TN12				1.8	60	2.0												
MW 126TN24							2.2	60	2.0									
MW 126TN48										2.8	60	2.0						
MW 126TN82													3.2	60	2.0			
MW 126TN18																3.7	60	2.0
MW 126TN52	1.6	60	2.0	1.8	60	2.0												
MW 126TN08							2.2	60	2.0	2.8	60	2.0						
MW 126TN88													3.2	60	2.0	3.7	60	2.0
MW 126TN28							2.2	60	2.0	2.8	60	2.0	3.2	60	2.0	3.7	60	2.0

Note: Outline drawings of cases are depicted on pages following these tables.



Outline Drawings

All dimensions are in inches and (mm). Drawings are in first angle projection.

HIGH ISOLATION/HIGH SPEED SWITCHES

CASE X1

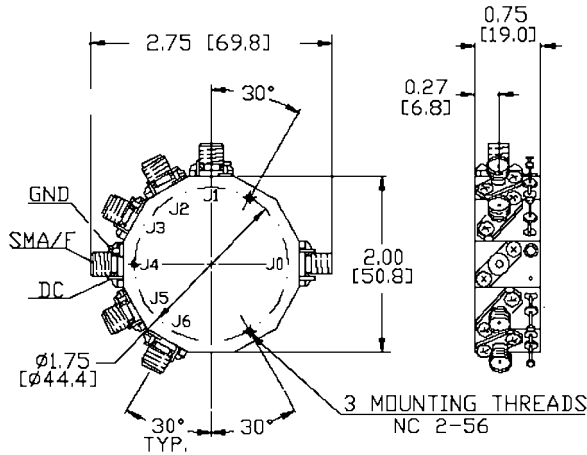

CASE X2

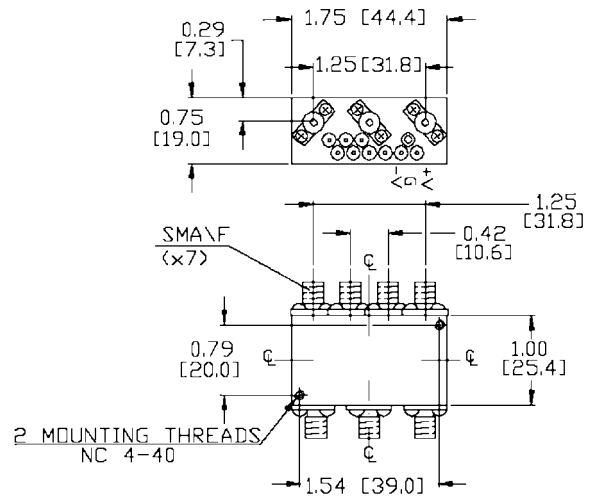

HIGH ISOLATION/LOW SPEED SWITCHES

CASE X

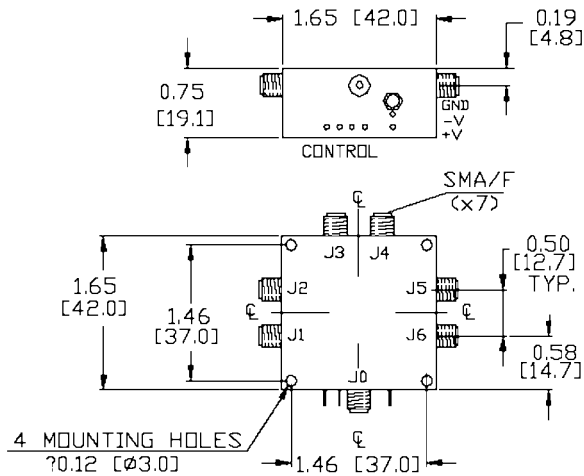

CASE X1

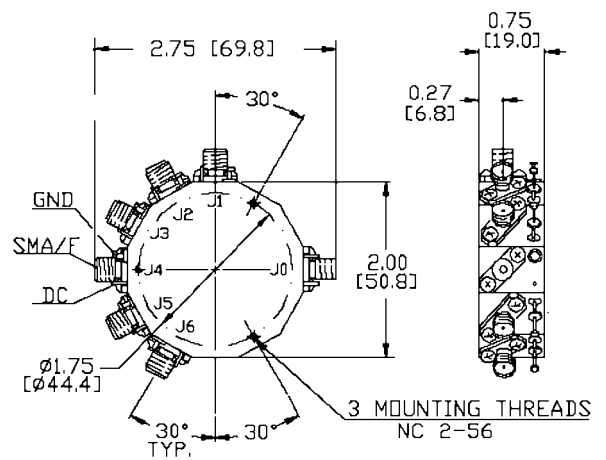

SP8T PIN Diode Switches

HIGH FREQUENCY

Series MW 128T

- ▶ Solid State
- ▶ Frequency Band 0.5 to 18 GHz
- ▶ Low Insertion Loss
- ▶ High Isolation
- ▶ Integral TTL Driver
- ▶ Hermetically Sealed

GENERAL INFORMATION

This series of SP8T switches is designed to give excellent performance for a wide range of military system applications in the 0.5 GHz to 18 GHz frequency range.

GENERAL SPECIFICATIONS

Power Handling Capability	100 mW
Operating Temperature Range	-55°C to +105°C
Storage Temperature Range	-65°C to +125°C
Reflective Switching Speed	30ns typical
Non-Reflective Switching Speed	30 ns typical

OPTIONS

- ▶ Low Video Leakage
- ▶ Switches Without Drivers
- ▶ Another Frequency Band
- ▶ Lower Insertion Loss Can Be Provided

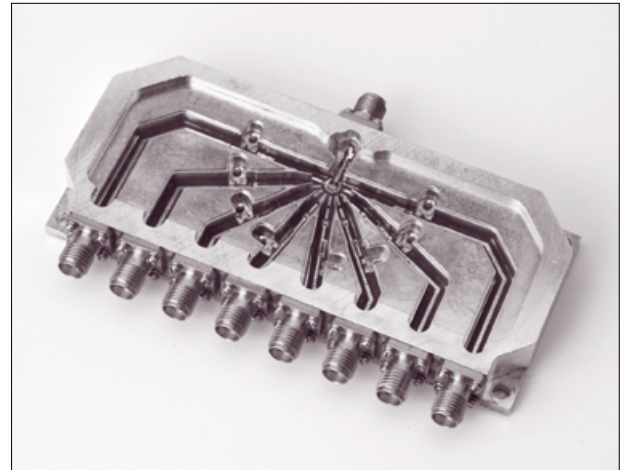

HOW TO ORDER

See the variety of switches on the next page, and follow the example below:

MW 128 T28 - H - H - 0 - A - U1
 1 - 2 - 3 - 4 - 5 - 6

LEGEND

1. Basic model number for an SP8T switch
2. Isolation (Reflective or Non-Reflective)
 H - High, 60 dB L - Low, 40 dB
3. Switching Speed

	Reflective	Non-Reflective
H - High	25 ns	30 ns
L - Low	100 ns	150 ns
4. TTL Control Logic
 0 - Logic "0" Low Loss
 Logic "1" Isolation
 1 - Logic "0" Isolation
 Logic "1" Low Loss
5. Power Supply
 - a. Voltage

A - +5V	-12V
B - +5V	-15V
C - +12V	-12V
D - +15V	-15V
 - b. Current

High Speed	+280 mA (+V)	- 60 mA (-V)
Low Speed	+320 mA (+V)	- 220 mA (-V)
6. Case type



SPECIFICATIONS

MW 128T High Isolation/High Speed/Low Speed Switches

High Frequency Reflective Switches

Model Number	Frequency (GHz)																	
	0.5 to 1			1 to 2			2 to 4			4 to 8			8 to 12			12 to 18		
	IL max (dB)	Isolation min (dB)	VSWR max	IL max (dB)	Isolation min (dB)	VSWR max	IL max (dB)	Isolation min (dB)	VSWR max	IL max (dB)	Isolation min (dB)	VSWR max	IL max (dB)	Isolation min (dB)	VSWR max	IL max (dB)	Isolation min (dB)	VSWR max
MW 128T51	1.5	60	2.0															
MW 128T12				1.8	60	2.0												
MW 128T24							2.0	60	2.0									
MW 128T48										2.4	60	2.0						
MW 128T82													3.0	60	2.0			
MW 128T18																3.7	60	2.0
MW 128T52	1.5	60	2.0	1.8	60	2.0												
MW 128T08							2.0	60	2.0	2.4	60	2.0						
MW 128T88													3.0	60	2.0	3.7	60	2.0
MW 128T28							2.0	60	2.0	2.4	60	2.0	3.0	60	2.0	3.7	60	2.0

High Frequency Non-Reflective Switches

Model Number	Frequency (GHz)																	
	0.5 to 1			1 to 2			2 to 4			4 to 8			8 to 12			12 to 18		
	IL max (dB)	Isolation min (dB)	VSWR max	IL max (dB)	Isolation min (dB)	VSWR max	IL max (dB)	Isolation min (dB)	VSWR max	IL max (dB)	Isolation min (dB)	VSWR max	IL max (dB)	Isolation min (dB)	VSWR max	IL max (dB)	Isolation min (dB)	VSWR max
MW 128TN51	1.8	60	2.0															
MW 128TN12				2.2	60	2.0												
MW 128TN24							2.4	60	2.0									
MW 128TN48										2.8	60	2.0						
MW 128TN82													3.4	60	2.0			
MW 128TN18																4.0	60	2.0
MW 128TN52	1.8	60	2.0	2.2	60	2.0												
MW 128TN08							2.4	60	2.0	2.8	60	2.0						
MW 128TN88													3.4	60	2.0	4.0	60	2.0
MW 128TN28							2.4	60	2.0	2.8	60	2.0	3.4	60	2.0	4.0	60	2.0

Note: Outline drawings of cases are depicted on pages following these tables.



Outline Drawings

HIGH & LOW SPEED SWITCHES

CASE U1

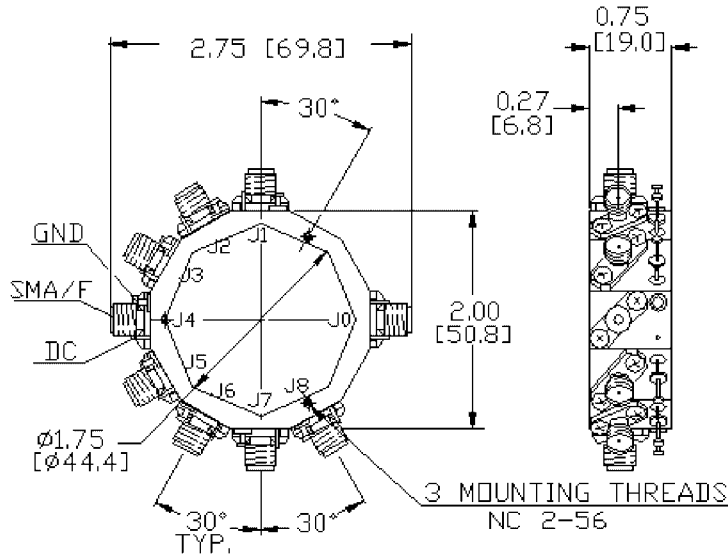

CASE U3

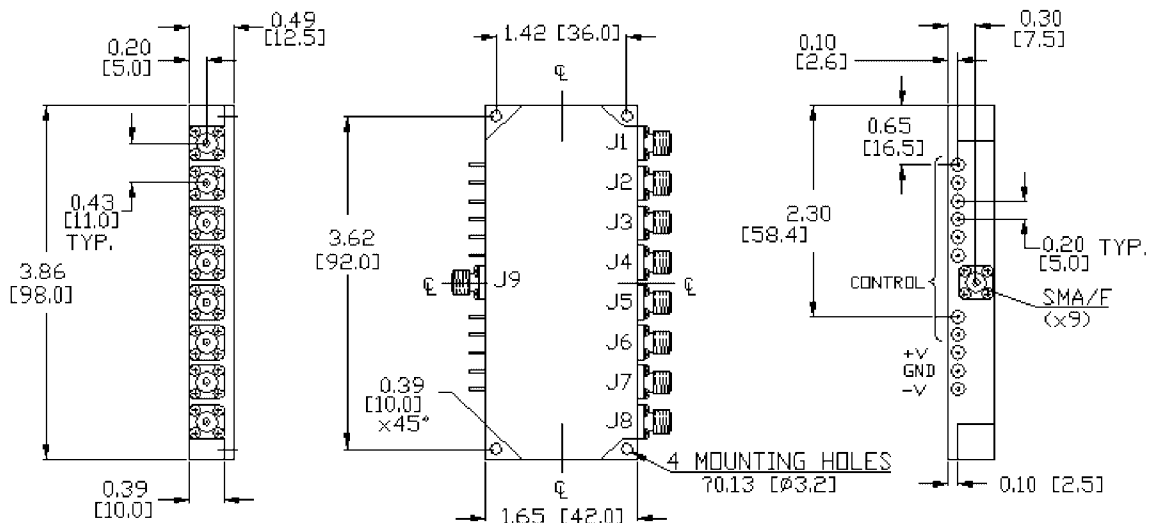

Transfer Switches

SERIES MW 12TR

GENERAL INFORMATION

Elisra's transfer switches offer optimized insertion loss, excellent VSWR and Isolation. Other optional models are available upon request.

The 12TR switches are supplied complete with integral driver and TTL control

GENERAL SPECIFICATIONS

Power Handling Capability	200 mW
Temperature Range	-55°C to +125°C
Storage Temperature Range	-65°C to +125°C
RF Connectors	SMA (female)
DC and Logic Connector	Solder pin

OPTIONS

- ▶ Other Frequency Bands are Available
- ▶ Higher Isolation is Available

HOW TO ORDER

To order an MW 12TR switch please follow the example

EXAMPLE:

$$\frac{\text{MW 12TR 01}}{1} - \frac{\text{D1}}{2} - \frac{\text{PS1}}{3}$$

LEGEND

- Select switch (basic model number)
- TTL Control Input (for units with drivers)
- Power Supply (for units with driver)
 - PS1: +5V and -5V
 - PS2: +5V and -12V
 - PS3: +12V and -12V
 - PS4: +15V and -15V
 - PS5: +5V for drop-in only

D	Logic	IL	Isolation
D1	0	J1-J2; J3-J4	J1-J4; J2-J3
	1	J1-J4; J1-J3	J1-J2; J3-J4
D2	0	J1-J4; J2-J3	J1-J2; J3-J4
	1	J1-J2; J3-J4	J1-J4; J4-J3

SPECIFICATIONS

MW 12RT Transfer Switches

Model Number	Frequency Range (GHz)	Insertion Loss max (dB)	VSWR max	Isolation (dB)	DC Requirements (mA)		Switching Time max (ns)	Case
					+V	-V		
MW 12TR 02	0.01 – 0.5	0.8	1.3	40	70	-	10μ	TR-2
MW 12TR 01	0.2 – 0.5	0.7	1.3	40	70	40	1μ	TR-1
MW 12TR 03	0.5 – 2	1.6	1.7	50	70	40	35	TR-1
MW 12TR 05	2 – 8	1.8	1.8	50	70	40	35	TR-1
MW 12TR 18	2 – 18	2.9	2.0	50	70	40	35	TR-1

Outline Drawings

All dimensions are in inches and (mm). Drawings are in first angle projection.

TRANSFER SWITCHES

CASE TR1

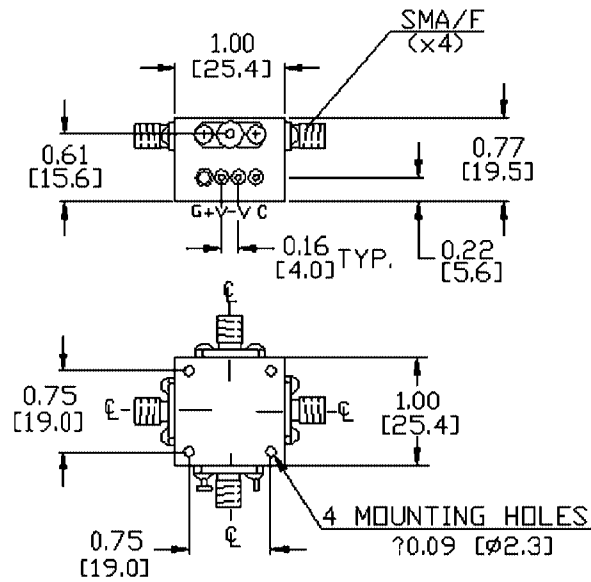

CASE TR2 (Drop-in)

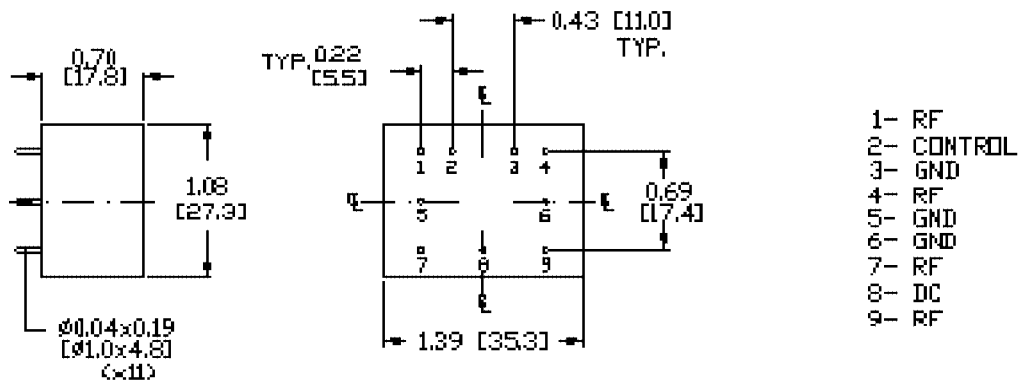

High Power PIN Diode Switches

SPST Through SP8T

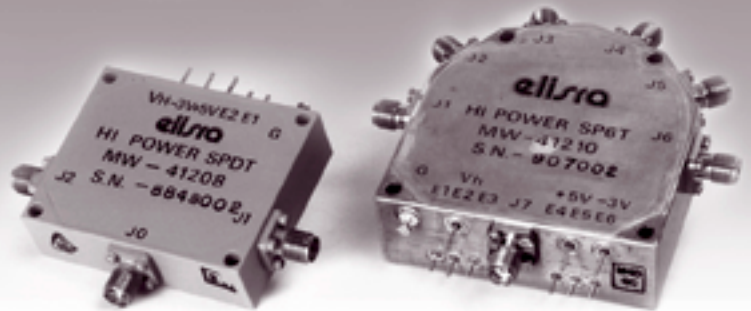

- ▶ Over 100 Watt CW and 1000 Watt Peak Power Handling Capacity
- ▶ .5 – 18 GHz Frequency Range Coverage
- ▶ Patented Transition Technology
- ▶ Low Loss, High Isolation
- ▶ Wideband, Narrowband
- ▶ SPST Through SP8T Configurations
- ▶ Compact and Lightweight
- ▶ High Reliable MIC Technology
- ▶ Integral TTL Driver
- ▶ Special Heat Dissipation Methodology
- ▶ TNC or SMA Standard Port Connections

GENERAL INFORMATION

The MW 412XY High Power PIN Diode Switches series offers a variety of performance options covering frequency bands from 0.5 to 18 GHz. Featuring cold switching power handling of 100 Watts CW in addition to extended peak power handling of over 1000 Watts, this series meets a spectrum of stringent requirements.

SPST through SP8T configurations are available, as the bandwidth can be extended over one octave for a reflective SPDT and over 30% relative for a reflective SP6T.

This series utilizes a precise and unique design, featuring a special heat sinking technology to obtain high reliability devices with high performances.

The whole series is hermetically sealed and SMA or TNC ported.

Base plate operating temperature is -55°C to +85°C.

Switching speed can be lowered to a minimum value of 500ns typical, depending on the nominal power handling.

The switches are available with an internally integrated TTL driver, or RS422 driver.

The whole series is available, utilizing MIL-STD-883 methods in the Quality Control system.

Custom designed switches are available upon request in addition to other standard units.

SPST Through SP8T

HIGH POWER

Series MW 4121XY

- ▶ Over 100 Watt CW and 1000 Watt Peak Power Handling
- ▶ Low Loss
- ▶ High Isolation
- ▶ Wideband, Narrowband
- ▶ SPST Through SP8T Configurations
- ▶ Small Size and Weight
- ▶ High Reliable MIC Technology

GENERAL INFORMATION

DC Selection and Driver Requirements

Two options of high power drivers are available depending mainly on the nominal power handling, the number of output ports and the required switching speed.

OPTIONS

Option I (High Power Drivers)

For switches with power handling up to 60W, the following driver is used:

+5V at 100 mA per arm

-15V at 20 mA

Option II (Super High Power Drivers)

For switches with power handling up to 100W, the following driver is used:

+5V at 20 mA

-5V at 100 mA per arm

+28V at 20 mA

Note; All currents are typical



HOW TO ORDER

Please specify the model number following the example below:

Example:

MW 4121 - $\frac{1}{1}$ - $\frac{4}{2}$ - $\frac{8}{3}$ - $\frac{20}{4}$ - $\frac{45}{5}$ - $\frac{T}{6}$ - $\frac{C}{7}$

This example presents the model number for an SPST switch operating between 4 to 8 GHz with 20W CW power handling, 45dB minimum isolation, cold switching capability and TTL controlled.

LEGEND:

- 1 - Number of outputs
(1 for an SPST; 8 for an SP8T)
- 2 - Lowest frequency in GHz
- 3 - Highest frequency in GHz
- 4 - CW power handling in Watts
- 5 - Minimum isolation in dB
(standard 20 dB and 40 dB, custom is possible)
- 6 - Control (T = TTL, E = ECL, 0 = RS442)
- 7 - Switching type
(C = cold switching, H = hot switching)



SPECIFICATIONS

High Power Switches Up to 50W CW

Model Number	Power Handling (Watt CW)	Frequency Range (GHz)	Insertion Loss (dB) typ./max.	Isolation (dB)typ./min.	Switching Speed (n-sec) typ.
MW-41212-1-2	50	1-2	0.6/1.0	35/30	600
MW-41212-2-4	50	2-4	0.8/1.2	30/25	600
MW-41212-4-8	50	4-8	0.9/1.3	26/20	600
MW-41212-6-18	50	6-18	1.0/1.4	24/18	600

High Power Switches 50 to 100W CW

Model Number	Power Handling (Watt CW)	Frequency Range (GHz)	Insertion Loss (dB) typ./max.	Isolation (dB)typ./min.	Switching Speed (n-sec) typ.
MW-41212P-1-2	100	1-2	0.7/1.1	35/30	600
MW-41212P-2-4	100	2-4	0.9/1.3	30/25	600
MW-41212P-4-8	100	4-8	1.0/1.4	26/20	600
MW-41212P-6-18	100	6-18	1.1/1.5	24/18	600

GENERAL SPECIFICATIONS

VSWR:

- ▶ 2:1 max.

Switching Type:

- ▶ Cold (No RF during the switching command).
- ▶ Hot switching up to 50 Watts is an option

CASES

Series MW 412 XY utilizes plated aluminum cases with a near perfect surface and heat sinks to obtain low thermal resistances ensuring high reliability and a long service life.

Standard cases produced at Elisra are depicted in the mechanical outline drawing. Special cases are available upon request. (See page 3-38)

Cellular PCS and ISM Applications

HIGH POWER

PIN Diode Switches

- ▶ 200W Average and 2000W Peak Power
- ▶ SPST Through SP8T Configuration
- ▶ Low Loss, High Isolation
- ▶ Compact and Lightweight
- ▶ Highly Reliable MIC Technology
- ▶ Integral TTL Driver
- ▶ Special Heat Dissipation Methodology
- ▶ N-type, TNC or SMA Standard Port Connections

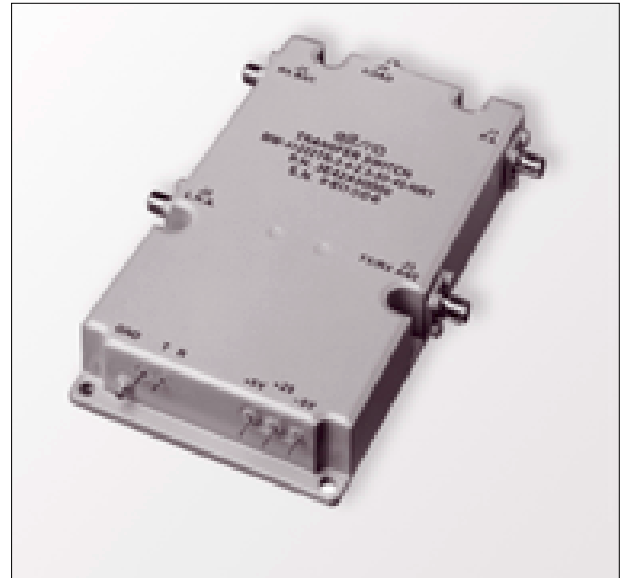

GENERAL INFORMATION

Elisra Cellular PCS and ISM High Power PIN Diode Switches offers 200 Watt average power handling capability covering frequency bands of cellular and PCS and ISM systems.

GENERAL SPECIFICATIONS

Configuration	Reflective
Switching Type	Cold Switching
Switching Speed	10 msec. Typ.
Voltage Supplies	+5V; -15V

OPTIONS

- ▶ 2.4 – 2.5 GHz Frequency Band
- ▶ Non-Reflective Configuration
- ▶ Transfer Switch Configuration
- ▶ Faster Switch Speeds



SPECIFICATIONS

High Power Switches

Model Number	Configuration	Frequency Range	Power Handling Av/Peak (Watt)	Insertion (Loss) (MHz)	Isolation typ./min. (dB)
MWP- 41211-CEL	SPST	824-960	200/2000	0.4/0.6	35/30
MWP- 41212-CEL	SPDT	824-960	200/2000	0.5/0.7	35/30
MWP- 41213-CEL	SP3T	824-960	200/2000	0.5/0.7	35/30
MWP- 41214-CEL	SP4T	824-960	200/2000	0.6/0.8	35/30
MWP- 41215-CEL	SP5T	824-960	200/2000	0.6/0.8	35/30
MWP- 41216-CEL	SP6T	824-960	200/2000	0.7/0.9	35/30
MWP- 41217-CEL	SP7T	824-960	200/2000	0.7/0.9	35/30
MWP- 41218-CEL	SP8T	824-960	200/2000	0.8/1.0	35/30
MWP- 41211-PCS	SPST	1850-2150	200/2000	0.6/0/8	30/25
MWP- 41212-PCS	SPDT	1850-2150	200/2000	0.7/0.9	30/25
MWP- 41213-PCS	SP3T	1850-2150	200/2000	0.7/0.9	30/25
MWP- 41214-PCS	SP4T	1850-2150	200/2000	0.8/1.0	30/25
MWP- 41215-PCS	SP5T	1850-2150	200/2000	0.8/1.0	30/25
MWP- 41216-PCS	SP6T	1850-2150	200/2000	0.9/1.1	30/25
MWP -41217-PCS	SP7T	1850-2150	200/2000	0.9/1.1	30/25
MWP -41218-PCS	SP8T	1850-2150	200/2000	1.0/1.2	30/25

Outline Drawings

All dimensions are in inches and (mm). Drawings are in first angle projection.

CASE A (SPST)

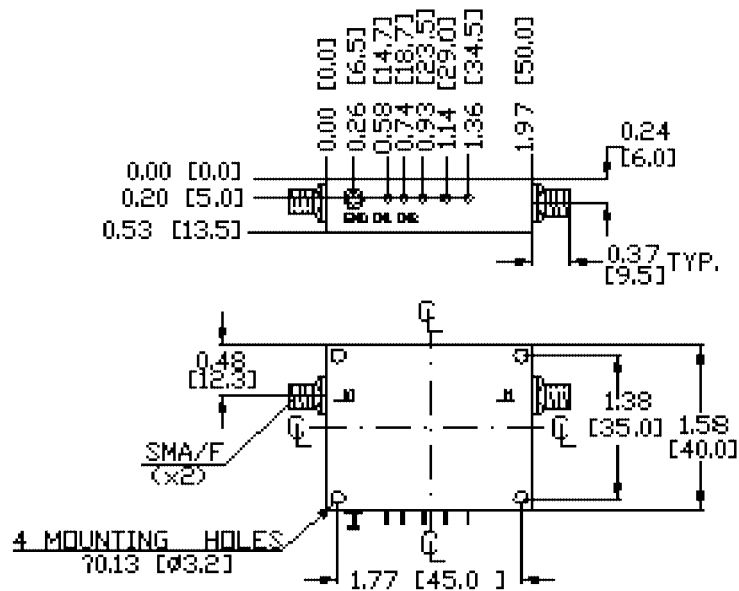

CASE B (SPDT)

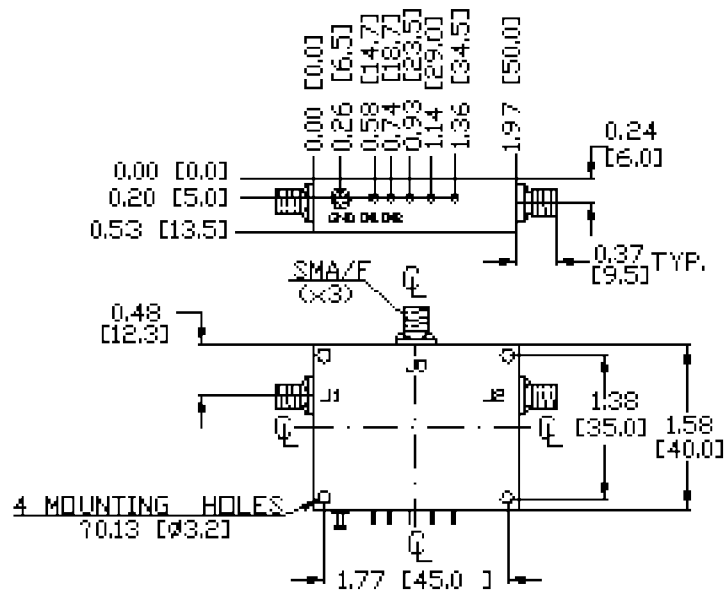

CASE B1 (SPDT)

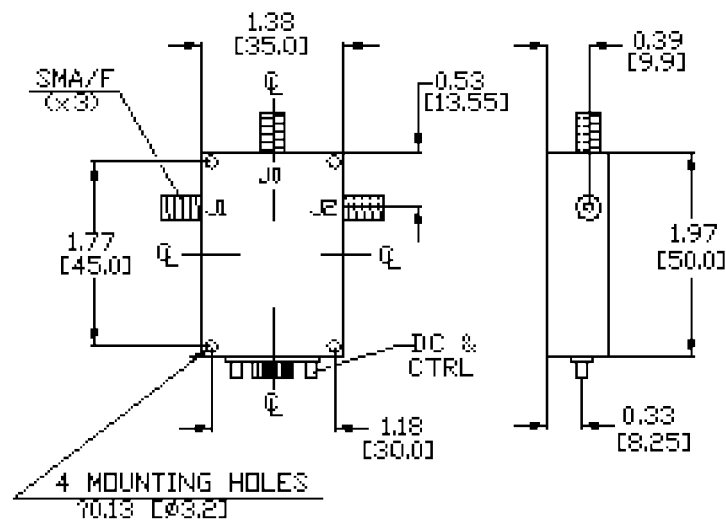

CASE C (SP3T-SP6T)

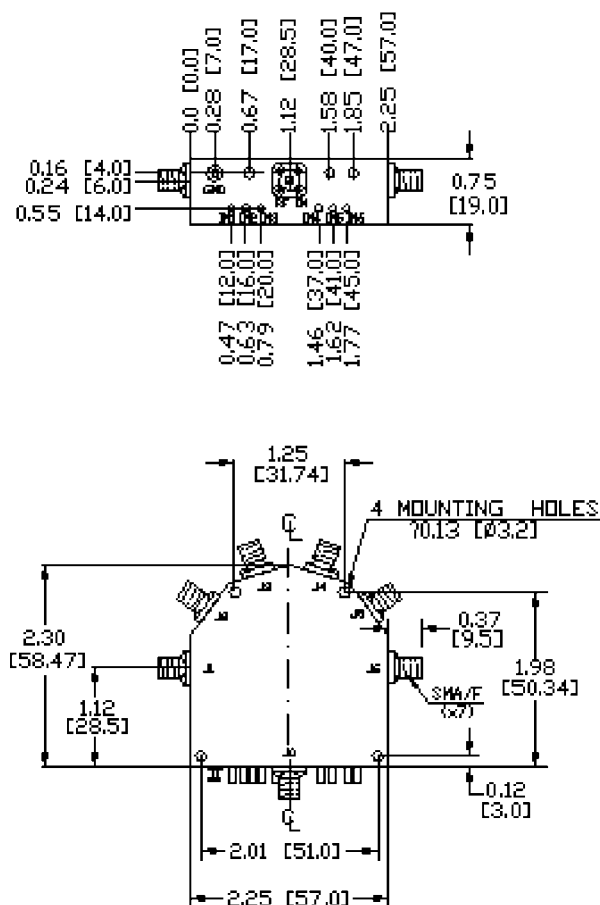

Index

elisra electronic systems ltd.

Microwave Division

Modulators and Translators

- ▶ BI-Phase Modulators
- ▶ Frequency Translators

Series MW BP BI-Phase

MODULATOR WITH DRIVER

- ▶ High Performance
- ▶ MIC Quadrature Hybrid Design
- ▶ TTL Compatibility
- ▶ Low Insertion Loss
- ▶ Small Packaging

GENERAL INFORMATON

This miniature 0° - 180° phase shifter combines broad frequency coverage and fast switching characteristics in a compact lightweight package configuration. The unit consists of silicon pin diode chips and broadband quadrature hybrid coupler circuits.

Reversing the TTL control polarity will switch the RF output phase by 180°.

GENERAL SPECIFICATIONS

Power Handling Capability	0.1W (CW)
Operating Temperature Range	55°C to +95°C
Power Supply Requirements	±12V, 40 mA
RF Connectors	SMA female



SPECIFICATIONS

MW BP Modulator with Driver

Model Number	Frequency Range (GHz)	IL max (dB)	VSWR max	Phase Delta (deg)	Switching Time (ns)	Amplitude Balance Between 2 States (dB)	Case
MW BP 74171	7.4 – 17.1	3.5	2.0	180±4°	100	1	AB

OPTIONS

- ▶ Other Frequency Ranges

HOW TO ORDER

To order the above mentioned frequency translator please state the model number. For other frequency ranges please contact manufacturer.

Outline Drawings

All dimensions are in inches and (mm). Drawings are in first angle projection.

CASE AB

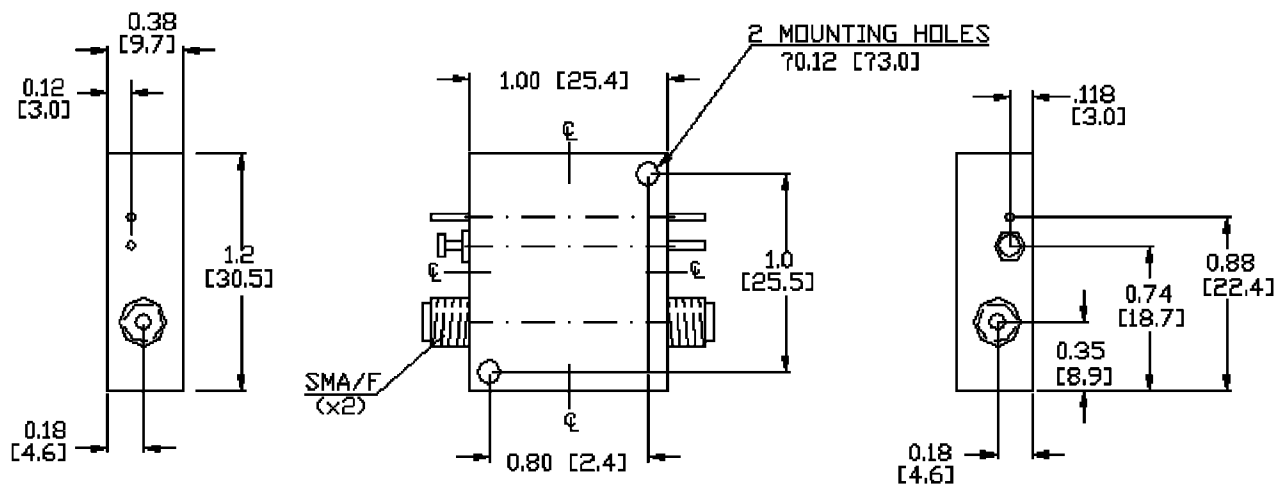

Series MW FT Frequency Translator

MW FT FREQUENCY TRANSLATOR

- ▶ High Performance
- ▶ MIC Quadrature Hybrid Design
- ▶ 6 Bit TTL Digital Drive
- ▶ Low Insertion Loss

GENERAL INFORMATION

Frequency translator comprises fast switching digital phase shifters. The input binary word advances or retards the phase in discreet increments.

The device is switched periodically through 360* is increments that are equal to the least significant bit. The frequency translator converts the frequency of an RF carrier to a lower or higher frequency.

GENERAL SPECIFICATIONS

Power Handling Capability	0.1W (CW)
Operating Temperature	-55°C to+105°C
Range Temperature Coefficient	0.025 dB/°C
Switching Time	30 ns max
Power Supply Requirements	5V at 200 mA at 50 mA
Frequency Translation	0 to 100 kHz
RF Connectors	SMA female

OPTIONS

- ▶ Other Frequency Ranges

HOW TO ORDER

To order the above mentioned frequency translator please state the model number. For other frequency ranges please contact manufacturer.

SPECIFICATIONS

MW FT Frequency Translator

Model Number	Frequency Range (GHz)	Translation Loss max (dB)	Carrier & Sideband Suppression (dBc)		Flatness max (±dB)	VSWR	Number of Bits	Case
			At Center Frequency	At Ends of Band				
MW FT20406	2.25 – 3.75	6	30	22	1.5	2.5	6	AT



Outline Drawings

All dimensions are in inches and (mm). Drawings are in first angle projection.

CASE AT

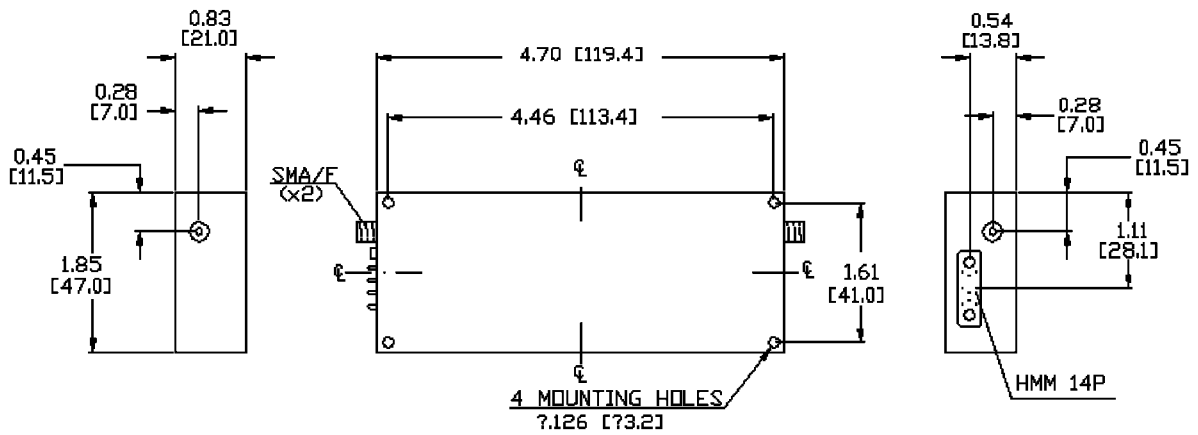

Mixers



- ▶ **Low Frequency Mixers**
- ▶ **High Frequency Mixers**

GENERAL INFORMATION

Elisra produces a complete line of high performance in numerous frequency ranges from a low of 0.5 – 2000 MHz to a high of 2 – 18 GHz. They are available in either connectorized or drop-in packages. These mixers offer high reliability as a major feature. They are 100% tested and built to most Army, Navy and Air Force military specifications (MIL-E-5400, Class II and MIL-E-16400).

DEFINITION

Single Sideband Conversion Loss (LC)

Normally referred to as a conversion loss, the single sideband conversion loss of a mixer is the ratio expressed in dB between the RF single input power to a mixer and the output power contained in the desired IF sideband.

Single Sideband Noise Figure (SSBNF)

The single sideband noise figure of a mixer is usually associated with its characteristics system loss (con-

version loss) and may usually be treated much the same as an attenuation pad of value L_c in the signal path.

1 dB Compression Point (1 dB Comp PT)

The 1 dB compression point of a mixer refers to an RF input overload level sufficiently large to cause a 1 dB increase in conversion loss compared to the small signal (linear) conversion loss case.

RF Port to IF Port Signal Isolation (L-I Iso)

The L-I port isolation is the ratio in dB between the L frequency power level incident at the L port of the mixer and the L frequency power emanating from the IF (I) port. (L-I feed through).

RF Port to IF Port Signal Isolation (R-I Iso)

The R-I port isolation is the power ratio in dB between the R frequency power level incident at the R port of the mixer and the R frequency power emanating from the IF (I) port. (R-I feed through).

L Port to R Port Signal Isolation (L-R Iso)

The L to R port isolation is the ratio in dB between the L frequency power level incident at the L port of the mixer and the L frequency power emanating from the R port. (L-R feed through).



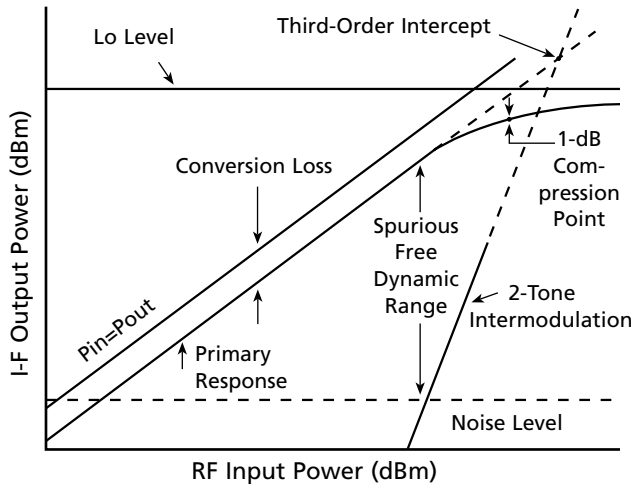

Figure 1. Intercept Diagram

Return Loss – Voltage Standing Wave Ratio (VSWR)

The return loss of a mixer port in dB is a measure of the difference between the incident (applied) power in dBm and the power reflected back toward the power source.

Input Intercept Point (IP)

The point on the input power coordinate at which the fundamental response and the third order spurious response curve intercept. It is often used to predict the 2-tone, 3rd-order suppression of a mixer. The higher the intercept point, the better the 3rd-order suppression. Relative to the input, the intercept point is typically 9 to 11 dB higher than the compression point.

Drive Level (DL)

Drive level is the power level of the local oscillator signal applied to the LO port of a mixer. Operating a mixer with the maximum recommended LO drive level will result in the best 2-tone performance, lowest conversion loss and flattest conversion loss versus frequency characteristics. A reduced LO drive level may help reduce mixer-generated intermodulation products and minimize 1/F noise in the output signal. A higher than recommended LO power level will result in an increased noise figure and higher LO feedthrough at both the RF and IF ports of the mixer (refer to Table 3).

Intermodulation Suppression

Typical harmonic intermodulation for mixer generated harmonics of the input signals are shown in Tables 1 and 2. Suppression numbers are for an FRF signal level at -10 dBm and FLO signal level of +7 dBm.

HOW TO ORDER

When placing your order, please follow the example below.

Example:

$$\frac{MW\ 14186}{1} - \frac{M}{2} - \frac{8}{3}$$

LEGEND

- 1 – Basic Model Number
- 2 – Drive Level Suffix
- 3 – Case Number

INTERMODULATION SUPPRESSION

TABLE 1. High Frequency Mixers*

FRF Harmonics \ FLO Harmonics	1	2	3	4	5
1	0	25	18	40	35
2	40	40	50	55	55
3	65	>70	65	>70	65
4	>70	>70	>70	>70	>70

TABLE 2. Low Frequency Mixers*

FRF Harmonics \ FLO Harmonics	1	2	3	4	5
1	-	25	10	30	30
2	40	45	50	55	55
3	63	70	69	>70	64
4	>70	>70	>70	>70	>70
5	>70	>70	>70	>70	>70

* Relative to desired IF output.



TABLE 3. Mixer Drive Level Characteristics

Local Drive Level	Drive Level Suffix	Local Drive Level Range (dBm)	Typical 1 dB Compression Point (dBm)	Typical Input Intercept Point per min LO Drive (dBm)
Low Drive	L	+10 to +13	+4	+14
Medium Drive	M	+13 to +15	+8	+17
High Drive	H	+17 to +19	+11	+20
Super High Drive	S	+20 to +23	+16	+25

SPECIFICATIONS

Standard Mixers

Model Number	Drive Level Suffix	Operating Frequency		Conversion Loss		Isolation				VSWR (typ)			Case
		FR&FL (GHz)	FI (MHz)	Typ (dB)	Max (dB)	L to I		L to R		R Port	L Port	I Port	
						Typ (dB)	Max (dB)	Typ (dB)	Max (dB)				
MMW 14158	L M	0.05÷2	DC÷500	8	10.5	20	17	25	20	2.5:1	2.5:1	2.5:1	7, 8
MW 14064	L M H,S	2÷6	5÷2000	7 7 7	10 10 11	25	15	25	15	2.5:1	2.5:1	2.5:1	7, 8
MW 141611	L M H,S	2÷16	5÷2000	6 7 8	10 10 11	25	15	25	15	2.5:1	2.5:1	2.5:1	7, 8
MW 14181	L M H,S	4÷18	5÷2000	6.5 7.5 8	10 10 11	25	15	25	15	2.5:1	2.5:1	2.5:1	7, 8
MW141846	L M H,S	4÷18	2000	7.5 8.5 9	10 10 11	30	15	30	15	2.5:1	2.5:1	2.5:1	7, 8
MW 14185	L M H,S	5÷18	5÷6000	7 8 8	11 11 11	30	15	30	15	2.5:1	2.5:1	2.5:1	7, 8
MW1418204	L M H,S	2÷18	5÷4000	7 8 9	11 11 11	30	15	30	15	2.5:1	2.5:1	2.5:1	7, 8
MW 1418216	L M H,S	2÷18	2000 TO 6000	6 7 7	10 10 11	30	15	30	15	2.5:1	2.5:1	2.5:1	7, 8
MW 1418218	L M H,S	2÷18	2000 TO 8000	7 7 8	11 11 11	30	15	30	15	2.5:1	2.5:1	2.5:1	7, 8
MW 14208	L M	2÷ 20	2000 TO 8000	8 9	11 11	30	15	30	15	2.5:1	2.5:1	2.5:1	7, 8

Outline Drawings

All dimensions are in inches and (mm). Drawings are in first angle projection.

CASE 7

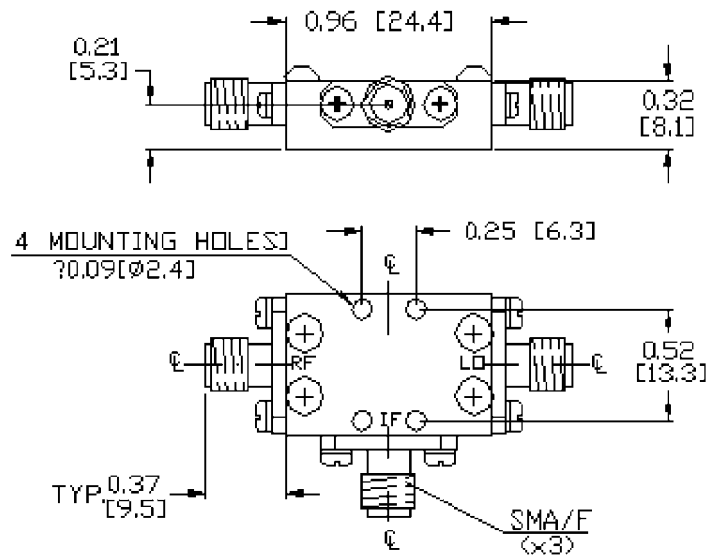

CASE 8

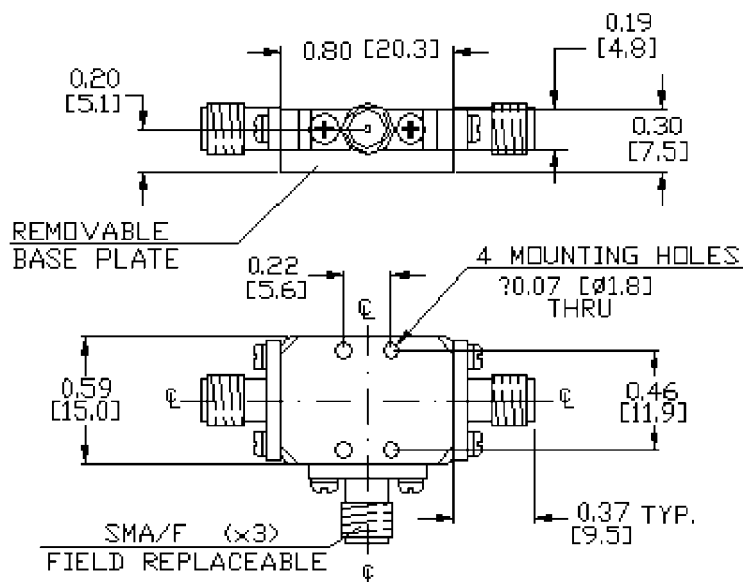

Digitally Controlled Attenuators



- ▶ Digitally Controlled Attenuators - DCA
- ▶ Step Attenuators

Series MW DC

DIGITALLY CONTROLLED ATTENUATORS

- ▶ High Performance
- ▶ MIC Quadrature Hybrid Design
- ▶ 60 dB Dynamic Range
- ▶ Temperature Compensated
- ▶ Non-Reflective
- ▶ VVA Upon Request

NOTES:

1. Mean attenuation is defined as the average of the maximum and minimum values of attenuation over the specified frequency range at a given control word.
2. Accuracy of attenuation is defined as the change from the required mean attenuation.

GENERAL INFORMATION

Power Handling Capacity	0.1 Watt (CW)
Mean Attenuation Range 1	60 dB
Temperature Coefficient	0.025 dB/°C
Accuracy of Attenuation 2	±1 dB
Switching Speed	1 μs
RF Connectors	SMA female

OPTIONS

- ▶ Other Models of Digitally Controlled Attenuators are Available Upon Request.

HOW TO ORDER

To order the above mentioned attenuator please state the model number. For other frequency ranges please contact manufacturer.

[Index](#)

elisra electronic systems ltd.

Microwave Division



SPECIFICATIONS

MW DC Digitally Controlled Attenuators

Model Number	Frequency Range (GHz)	Step Size (dB)	Number of Bits	Insertion Loss max (dB)	VSWR max	Flatness (\pm dB)		DC Power Supply		Operating Temperature Range ($^{\circ}$ C)	Case
						Up to 30 dB	Up to 60 dB	(V)	(mA)		
MW DC20606	2 – 6	1	6	2.5	2.1	2.5	3.00	+5 +15 -15	170 150 50	-55 to +105	AD
MW DC60186	6 – 18	1	6	6.0	2.2	2.5	3.00	+5 +12 -12	200 100 20	-55 to +105	BD
MW DC20406	2 – 4	1	6	2.0	2.0	1.25	1.75	+15 -15	150 50	0 to +70	CD
MW DC40806	4 – 8	1	6	3.0	2.0	1.25	2.00	+15 -15	150 50	0 to +70	CD
MW DC50107	5 – 10	0.5	7	2.6	2.0	1.25	1.75	+12 -12	120 35	0 to +70	DD



Outline Drawings

All dimensions are in inches and (mm). Drawings are in first angle projection.

CASE AD

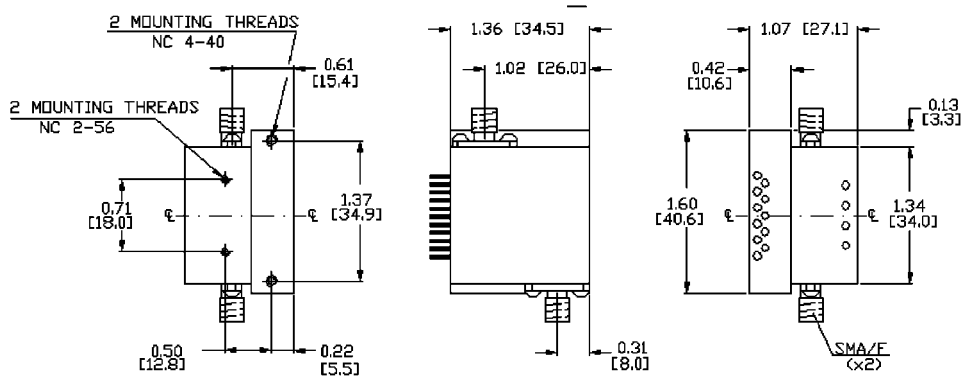

CASE BD

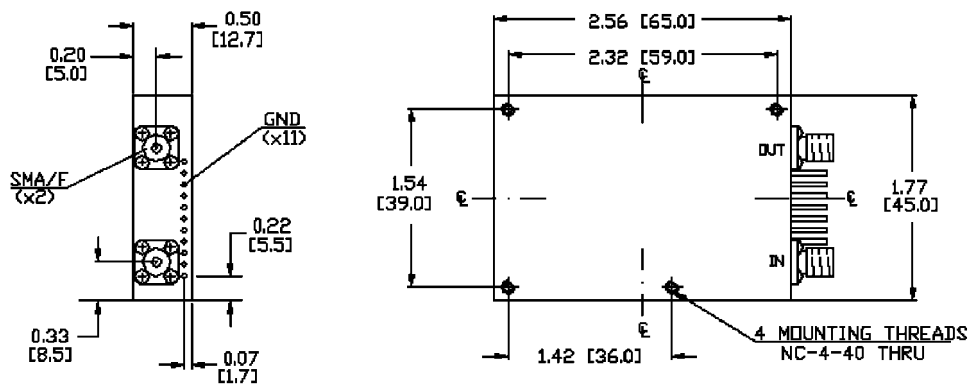

CASE CD

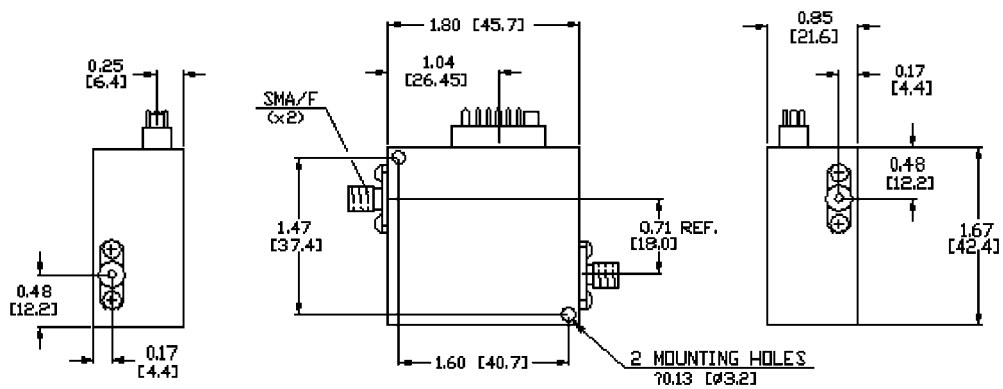

CASE DD

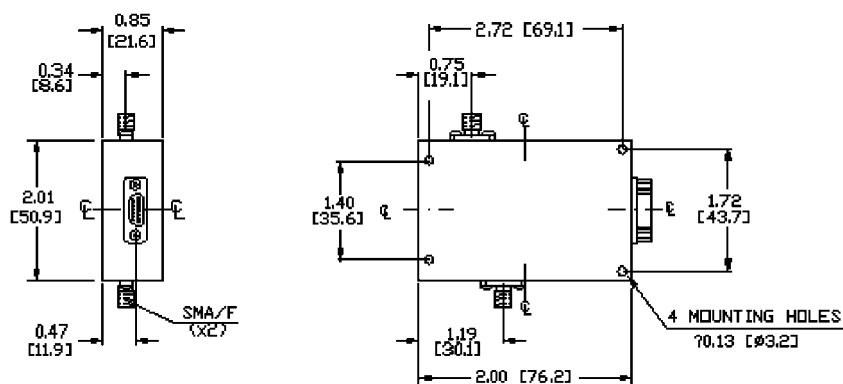

[Index](#)

elisra electronic systems ltd.

Microwave Division

Step Attenuators

SERIES MW SA

- ▶ High Performance
- ▶ High Speed
- ▶ Temperature Compensated
- ▶ Flat Frequency

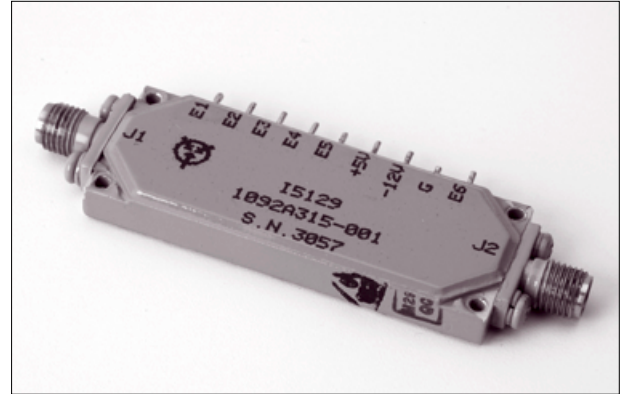

GENERAL INFORMATION

This series of step attenuators utilizes beam lead pin diodes as the switching element and T pad resistors as the attenuation element. These T pads are switched in any combination of discrete values by pairs of high speed diode switches.

Any value of attenuation between 0 to 63 dB in 1 dB steps can be provided by changing the input word.

GENERAL SPECIFICATIONS

Attenuation Range	up to 63 dB
Switching Speed	50 ns
Accuracy of Attenuation	±1 dB
Operating Temperature Range	-55°C to +95°C

HOW TO ORDER

To order the above mentioned attenuator please state the model number. For other frequency ranges please contact manufacturer.

SPECIFICATIONS

MW SA Step Attenuators

Model Number	Frequency Range (GHz)	Step Size (dB)	Number of Bits	Insertion Loss max (dB)	VSWR max	Flatness (±dB)		DC Power Supply		Attenuation Range (dB)	Power Handling Capability (W)	Case
						Up to 30 dB	Up to 60 dB	(V)	(mA)			
MW SA20606	2 – 6	1	6	5.0	2.0	0.7	1.5	+5 -12	150 140	63.0	0.1	AST
MW SA20602	2 – 6	30	2	2.5	1.8	0.5	1	+5 -12	100 50	60.0	0.1	BST
MW SA80101	8 – 10	30	1	2.0	1.8	0.5	-	+5 -12	50 50	30.0	0.1*	CST

* Operating temperature range is -55°C to +70°C.



Outline Drawings

All dimensions are in inches and (mm). Drawings are in first angle projection.

CASE AST

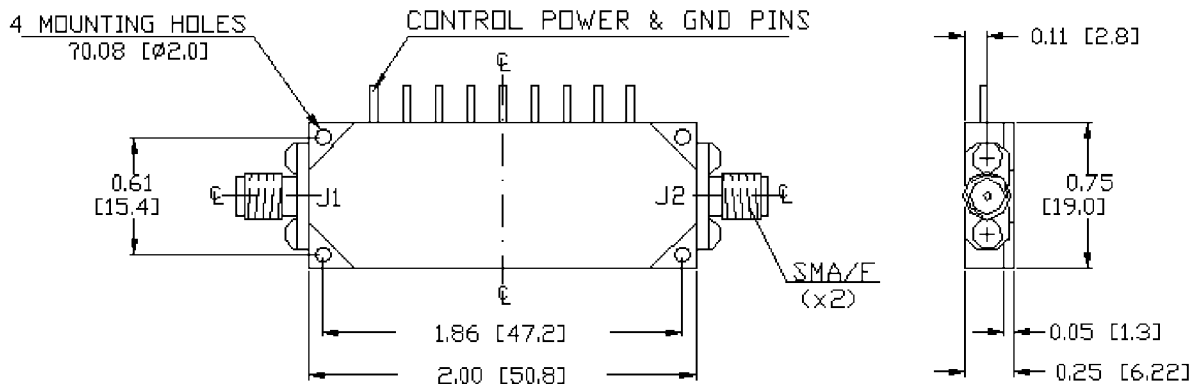

CASE BST

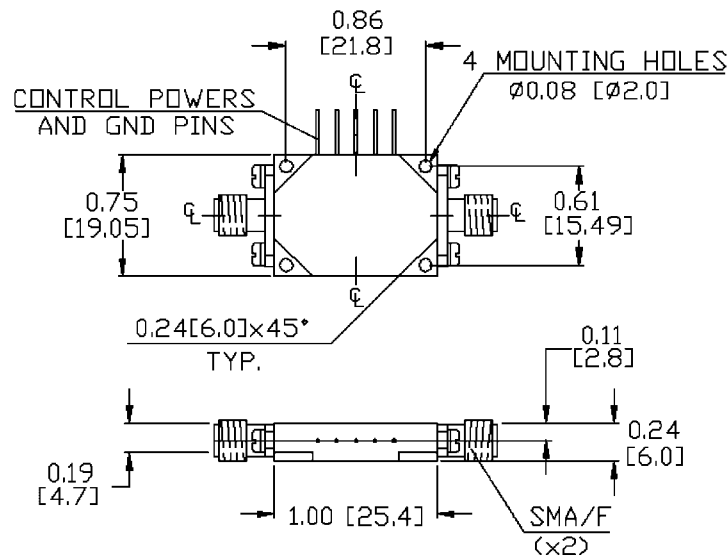

CASE CST

