

Aeronautical radio navigation measurement solutions

Application Note

Products:

R&S [®] SMA100A	R&S [®] EVS300
R&S [®] FSU	R&S [®] NRP-Z81
R&S [®] FSQ	R&S [®] CMS57
R&S [®] FSMR	R&S [®] RTO

This application note highlights various aeronautical radio navigation signals such as VHF omnidirectional radio range (VOR), instrument landing system (ILS) for glide slope (GS) and localizer (LLZ), as well as marker beacon (MB).

R&S[®] test and measurement solutions for avionics navigation equipment are introduced based on application scenarios, including calibration, research and development, field tests, and transceiver testing.

Table of Contents

1	Overview	3
1.1	Avionics.....	3
1.2	Spectrum allocation	4
1.3	Navigational and landing instrumentation	5
2	Aeronautical radio navigation	7
2.1	VHF omnidirectional radio range (VOR)	7
2.2	Instrument landing system (ILS).....	9
2.2.1	Instrument landing system - glide slope (ILS-GS)	10
2.2.2	Instrument landing system- localizer (ILS-LOC/LLZ)	11
2.2.3	Marker beacon (MB)	13
2.3	Applications Overview	14
3	Application Scenarios	16
3.1	Receiver tests using the R&S® SMA100A signal generator	16
3.2	Calibration of VOR/ILS signal generators and service monitors using the R&S® FSMR measuring receiver	21
3.2.1	Measuring VOR signals using the R&S® FS-K15 option	21
3.2.2	Measuring ILS signals using the R&S® FS-K15 option	22
3.3	Ground and flight inspection using the R&S® EVS300	23
3.4	Transceiver service testing using the R&S® CMS57	31
3.5	DME pulse analysis using the R&S® RTO oscilloscope.....	33
4	Conclusion.....	35
5	References	35
6	Abbreviations	36
7	Ordering Information	37

1 Overview

1.1 Avionics

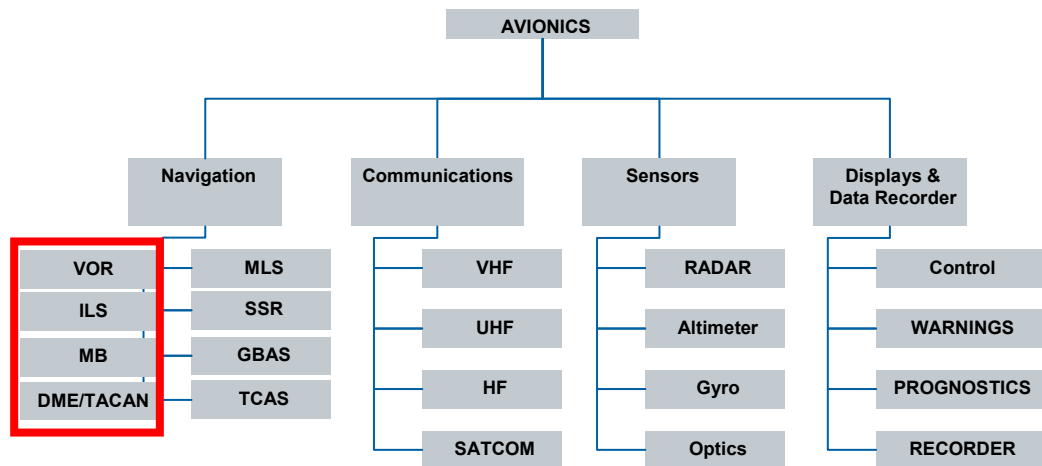

Figure 1: Simple breakdown of avionics structure, with emphasis on **selected** navigation systems

Avionics (a term that combines *aviation* and *electronics*) applications have highly demanding and rigorous requirements due to their operational environment. The failure of an aircraft avionics component may place lives at immediate risk. As such, it is vital that all aspects of avionics equipment be monitored and measured closely for installation and servicing defects.

As shown in Figure 1, avionics is broadly classified as covering the categories of navigation, communications, sensors, and displays and data recorder. With the exception of fly-by-wire electronic control flight systems, the classification above remains valid for most modern aircraft, both civil and military.

The emphasis of this application note will be to highlight the various Rohde & Schwarz test solutions for aeronautical radio navigation signals. Such signals include very high frequency omnidirectional radio range (VOR), instrument landing systems - glide slope (ILS-GS), instrument landing systems - localizer (ILS-LOC), and marker beacon (MB). Distance measurement equipment for civil applications (DME) and tactical air navigation (TACAN) for military applications are introduced in [Application Note 1GP74](#) and as such will not be explored in depth here.

Generation and analysis measurement solutions are discussed; in particular, which solution best aligns to the requirements of different aeronautical customers, be it calibration laboratories, airport authorities, production, or even research and development.

1.2 Spectrum allocation

Table 1: RF spectrum allocation (typical) for aeronautical radio navigation signals

	100 kHz	1 MHz	10 MHz	100 MHz	1 GHz	5 GHz	10 GHz	Frequency Range (Hz)
HF Comm.			■					3-30 MHz
VHF Comm.				■				118-156 MHz
UHF Comm.					■			225-400 MHz
MB				■				75 MHz
ILS-GS					■			329-335 MHz
ILS-LLZ				■				108-112 MHz
VOR				■				108-118 MHz
DME						■		1025-1150 MHz, 962-1213 MHz
GPS (L1/L2)							■	1575.42 MHz(L1), 1227.6 MHz(L2)

High frequency (HF) communications, spanning from 3 MHz to 30 MHz, utilizes single sideband, suppressed carrier modulation with a bandwidth of about 2.5 kHz, typically at several hundred watts of transmitted power. However, HF propagation varies with frequency, weather, time of day, and ionospheric conditions. Very high frequency (VHF) communications span two different bands: 30 MHz to 88 MHz exclusively for military users, and 118 MHz to 156 MHz for both civil and military users, with standard double sideband AM modulation at 40 dBm to 45 dBm of transmitted power. Ultra high frequency (UHF) communications encompasses both VHF and UHF operating from 225 MHz to 400 MHz. FM-modulated schemes employ 40 dBm to 50 dBm of transmitted power, and AM-modulated schemes employ 40 dBm to 44 dBm of transmitted power. This band is often used by military users for various pulsed, frequency hopping and electronic counter-counter measures (ECCM), such as anti-jamming.

Long range *enroute* radio navigation such as the global positioning system (GPS) operates at slightly higher ranges of the spectrum band. Line-of-sight (LOS) approach radio navigation such as very high frequency omnidirectional radio range (VOR), instrument landing systems - glide slope (ILS-GS), instrument landing systems - localizer (ILS-LOC), and marker beacon (MB) operate at HF and VHF bands. Distance measurement equipment (DME) is allocated for operation within UHF bands.

1.3 Navigational and landing instrumentation

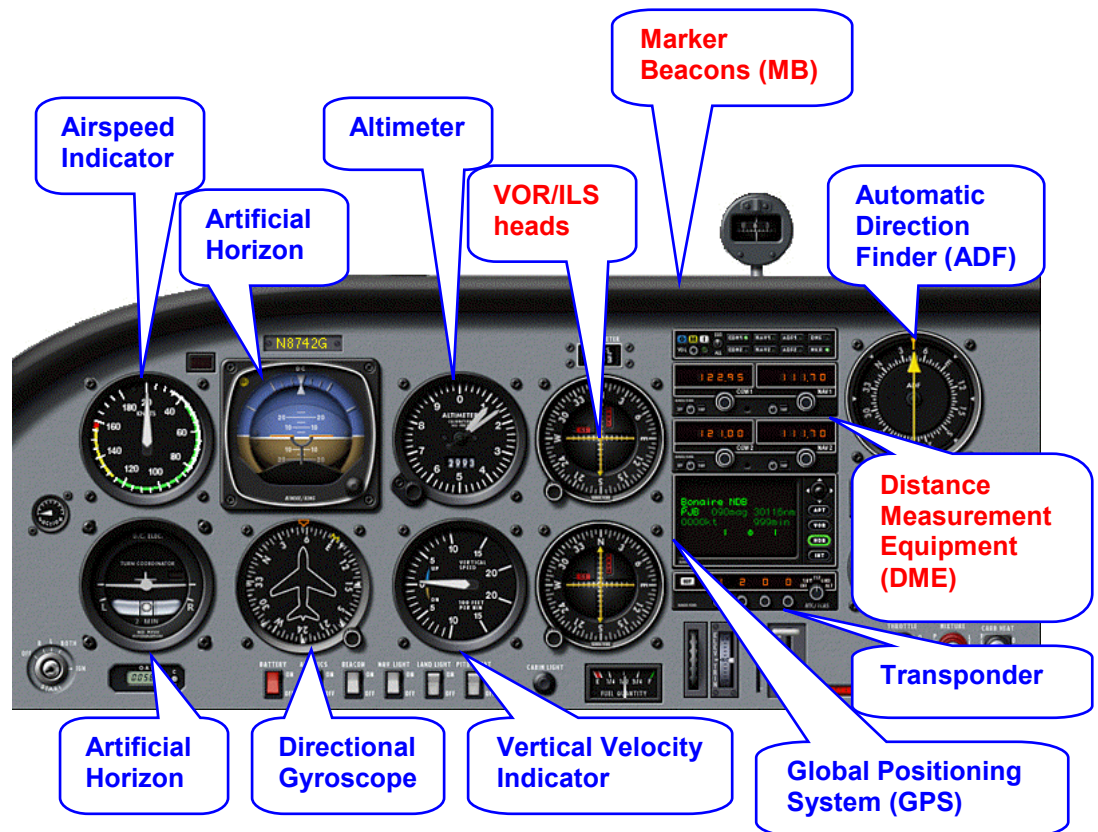

Figure 2: Cockpit view of various navigation, landing, and DME instrumentation

From the perspective of the pilot in the cockpit of an aircraft, VOR/ILS and MB are analog-based displays and GPS forms the digital-based displays. The licensed aircraft engineer (LAE) is responsible for ensuring the accuracy and reliability of the instrumentation before the pilot takes over. Figure 2 focuses on the aeronautical radio navigation aspect, not the auxiliary control and power instrumentation.

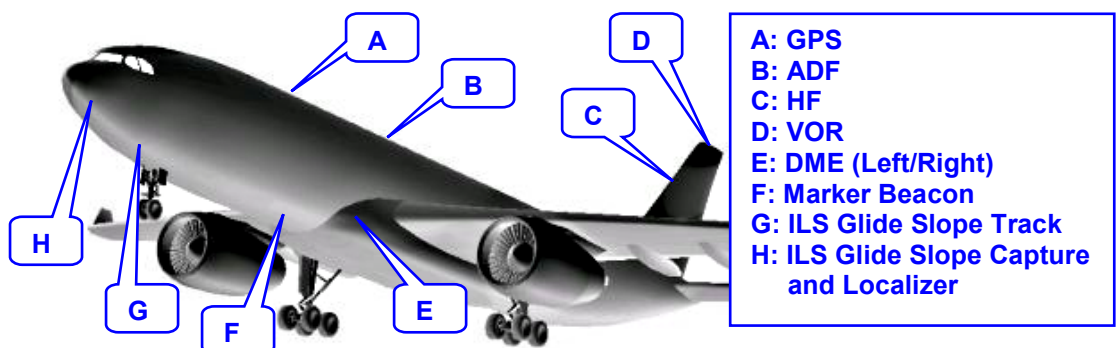

Figure 3: Location of on-board aircraft aeronautical radio navigation aids

The aeronautical radio navigation equipment antenna transceivers are typically located on the nose, fuselage, and vertical stabilizer, depending on the most likely signal direction of arrival (DOA). For example, GPS transceivers are located at the uppermost portion for better satellite reception and the ILS glide slope and localizer are located below for better reception during landing approaches.

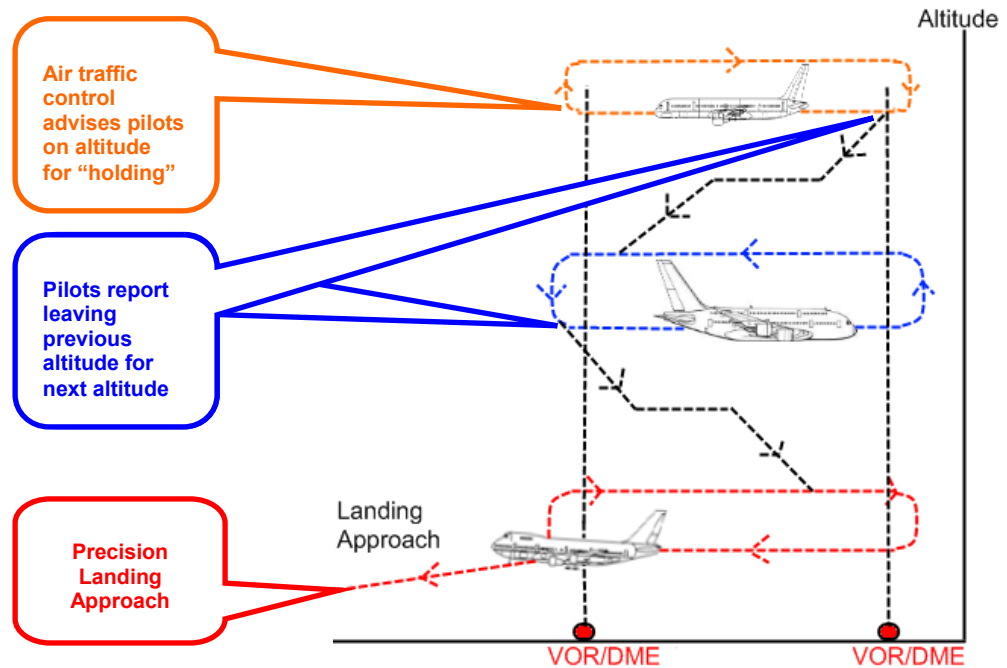

Figure 4: Transitioning from "holding stack" to landing approach navigation

Enroute navigation includes the use of GPS, RADAR, and VHF with air traffic control (ATC), distance measurement equipment (DME), and automatic direction finder (ADF). For example, when using the GPS and ADF, pilots will know the aircraft position and will request landing clearance from ATC. For heavy air traffic, ATC sequences the aircraft arrivals, with pilots executing a "holding stack" – usually based on a "racetrack" pattern (refer to Figure 4). VOR/DME stations serve as waypoints before the final descent and landing approach, guided by the distance from the runway as provided by marker beacons (MB) and the instrument landing system (ILS).

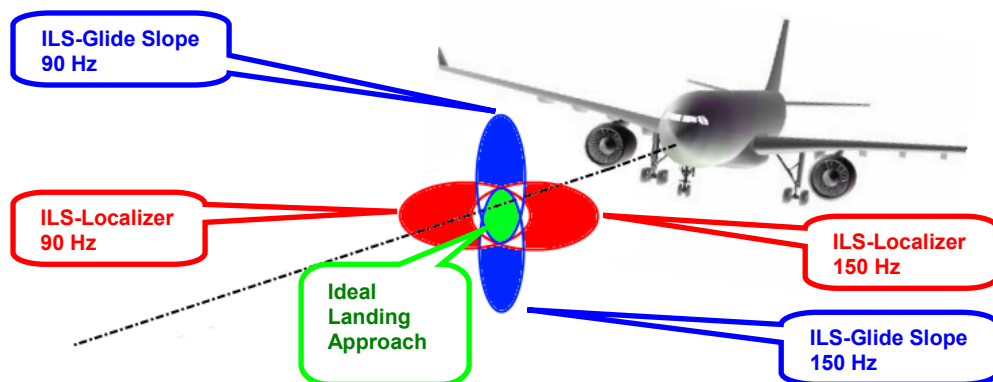

Figure 5: Approach navigation using instrument landing system (ILS)

As a method of approach navigation, the instrument landing system (ILS) includes three functions: Glide slope (GS), localizer (LOC or LLZ), and marker beacons (MB). The glide slope ensures that the vertical descent path is aligned to the ideal descent path in tandem with the distance from the runway based on the marker beacons. The localizer ensures that the lateral left-right approach is aligned with the center of the runway. MB in landing approach is gradually being replaced by DME, but is essential nonetheless for existing airport infrastructure.

2 Aeronautical radio navigation

2.1 VHF omnidirectional radio range (VOR)

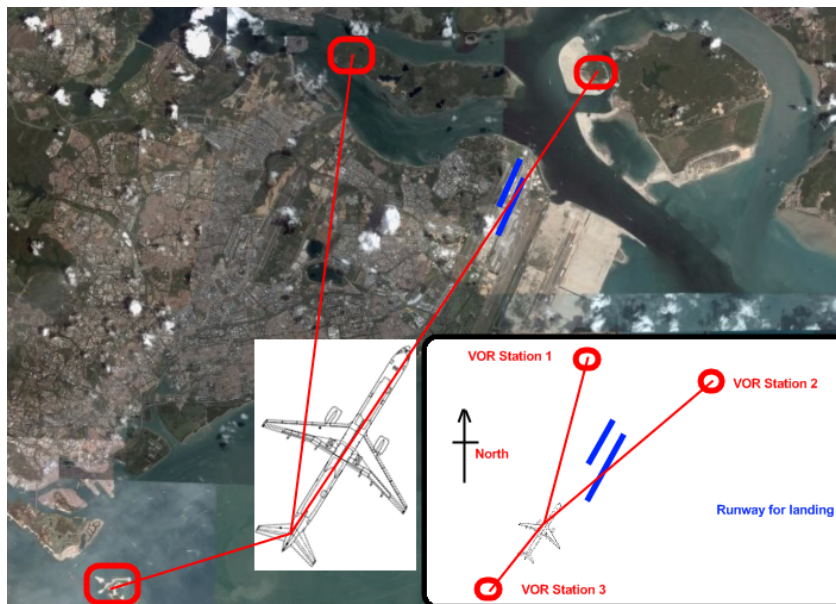

Figure 6: Final descent approach localization using VOR stations

VHF omnidirectional radio range (VOR) operates at VHF frequencies of 108 MHz to 118 MHz to provide aircraft with a bearing to the ground station location. By demodulating the signal of a VOR transmitter station, the VOR receiver of an aircraft is able to provide bearing information relative to the transmitter station [1]. The aircraft position can be obtained by triangulating two or more stations. VOR stations give a relative bearing with respect to ground stations.

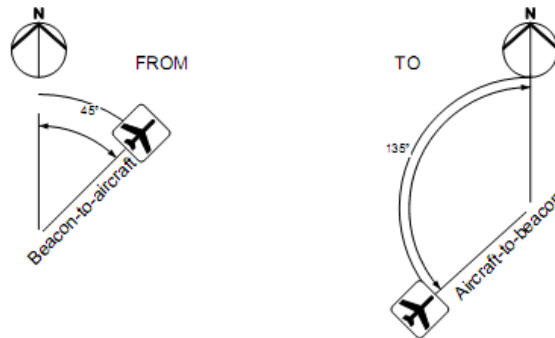

Figure 7: FROM and TO bearing angle conventions

A VOR instrument in the cockpit can be set to either a FROM or a TO configuration. In the FROM convention, the beacon is made the reference point and the bearing angle is between magnetic north and the beacon-to-aircraft line. For the TO convention, the aircraft is made the reference point and the bearing angle is between magnetic north and the aircraft-to-beacon line. $\varphi_{TO} = 180^\circ - \varphi_{FROM}$ (see Figure 7).

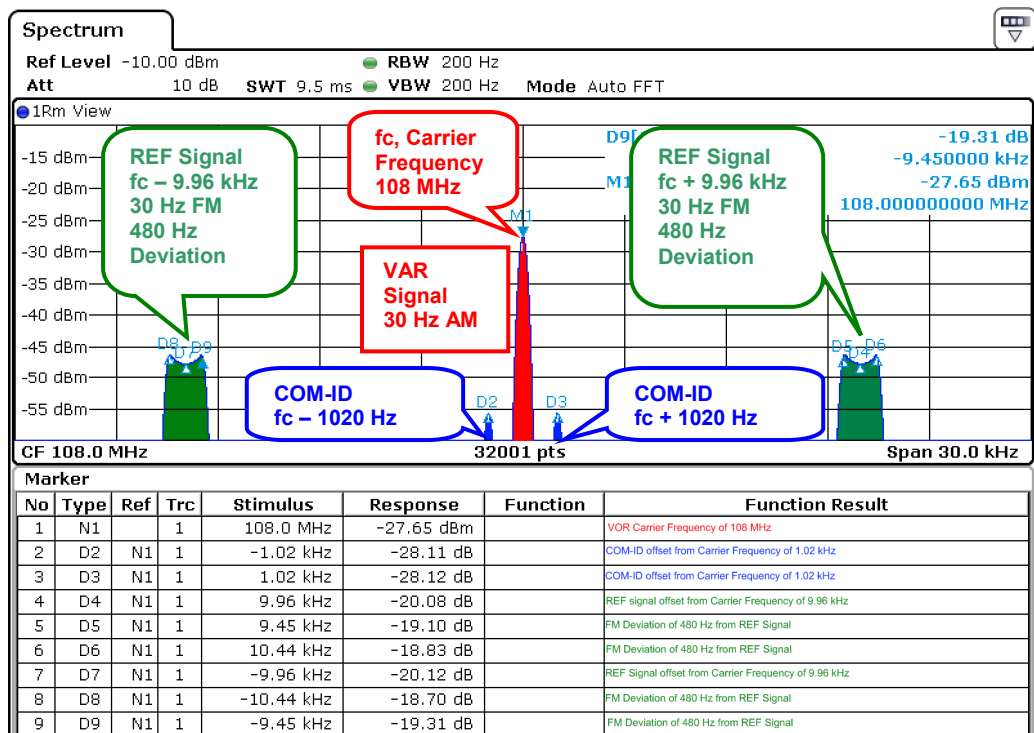

Figure 8: VOR spectrum (MAX HOLD trace function and LOG SCALE) shown on R&S®FSV signal analyzer

VHF omnidirectional radio range (VOR) operates continuously at carrier frequencies of 108 MHz to 118 MHz, with the code identification, or COM/ID, using up to four letters in Morse code, transmitted on a modulation tone of 1.020 kHz. Figure 8 shows an example VOR spectrum with a 108 MHz center frequency. The spectrum is displayed in logarithmic scale using the R&S®FSV.

The 30 Hz reference (REF) signal is frequency modulated with a peak deviation of 480 Hz on a 9.96 kHz carrier. This frequency modulated subcarrier then undergoes amplitude modulation on the VOR carrier frequency. The variable (VAR) phase signal is amplitude modulated directly on the VOR carrier frequency using an antenna array that establishes a rotating “cardioid” shaped antenna pattern rotating at a 30 Hz rate, or 1800 rpm. The REF signal is transmitted from a fixed omnidirectional antenna, and thus contains no time-varying spatial modulation signals. The relative phase comparison between both 30 Hz signals is proportional to the bearing of the transmitter due to this rotation.

The two signals are set to be in phase at magnetic north, 90 degrees out of phase at magnetic east, 180 degrees out of phase at magnetic south, and 270 degrees out of phase at magnetic west. VOR receivers function by receiving both VAR and REF signals, comparing their phase, and displaying the bearing to the station to the pilot for the FROM convention.

2.2 Instrument landing system (ILS)

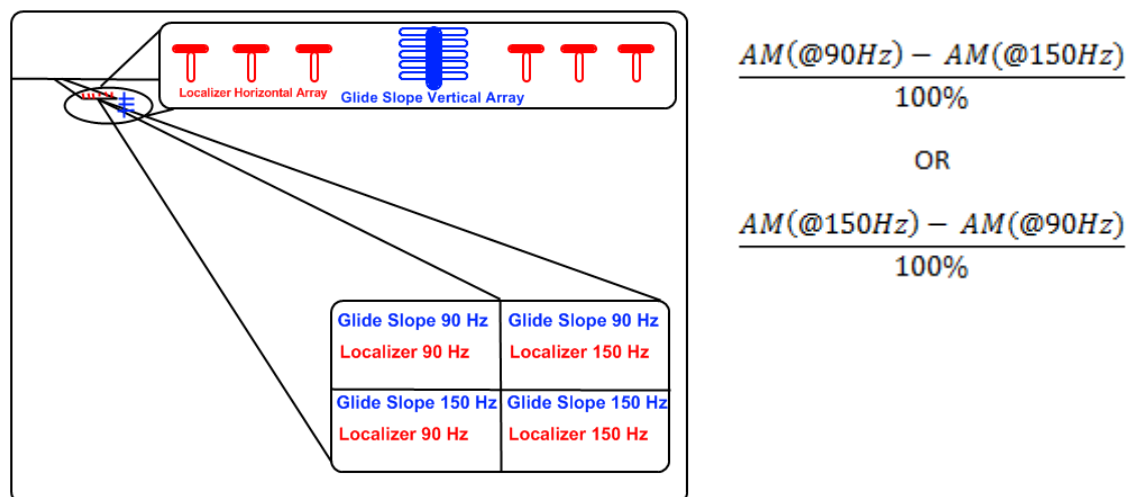

Figure 9: ILS 90 Hz and 150 Hz convention

The instrument landing system (ILS) provides aircraft pilots with landing approach data relative to the ideal landing course. This is especially critical when visibility is poor due to bad weather, night landings, and crosswind approaches.

ILS-GS enables the pilot to steer up or down correctly during landing. This vertical correction is performed via two AM carriers with an AM depth of 40 % operating at a frequency range between 329 MHz and 335 MHz. For the aircraft approach, the upper tone is modulated at a frequency of 90 Hz by default, and the lower tone at a frequency of 150 Hz [2]. Vertical axis phased antenna arrays are utilized for beamforming.

ILS-LOC/LLZ enables the pilot to steer left or right correctly during landing. This lateral correction is performed via two AM carriers with an AM depth of 20 %, operating at a

frequency range between 108 MHz and 112 MHz. For the aircraft approach, the left tone is modulated at a frequency of 90 Hz by default, and the right tone at a frequency of 150 Hz [2]. Horizontal axis phased antenna arrays are utilized for beamforming.

“Difference in depth of modulation” (DDM) is the relative difference between the two AM carriers of 90 Hz and 150 Hz. By demodulating the received glide slope signal and calculating the difference in depth of modulation (DDM) between the two tones, the ILS-GS provides the pilot with vertical course profile data. Likewise, by demodulating the received localizer signal and calculating the difference in depth of modulation (DDM) between the two tones, the ILS-LOC/LLZ provides the pilot with lateral course data. Marker beacons indicate the distance from the start of runway at different audible tones.

Simultaneous **ILS-GS**, **ILS-LOC/LLZ**, and marker beacons provide aircraft with a descent approach path that is reliable and approved by ICAO.

2.2.1 Instrument landing system - glide slope (ILS-GS)



Figure 10: ILS-GS antenna

The glide slope transmitter is located near the end of the runway (nearest to the start of the aircraft approach). Typically, vertically aligned antennas transmit two intersecting main beams on top of one another at carrier frequencies between 329 MHz and 335 MHz. The top beam is usually modulated at 90 Hz and the beam below at 150 Hz. With careful field installation and maintenance, the received signal will be modulated equally along the centerline of the glide slope.

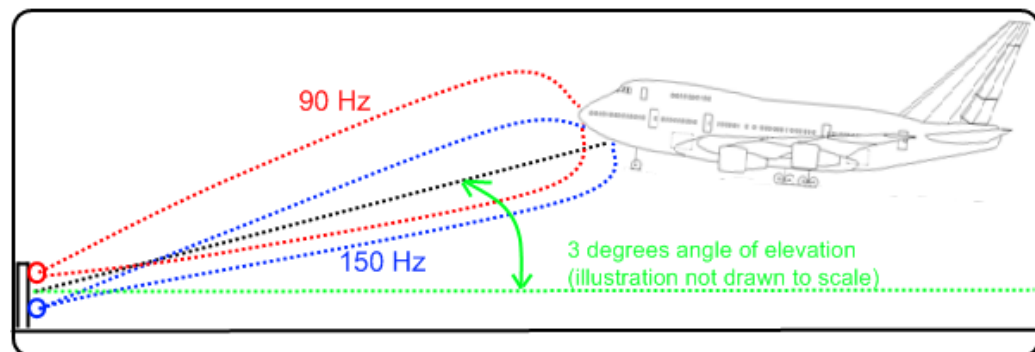

Figure 11: Difference in depth of modulation (DDM) for ILS-GS (side view)

The total beam width is approximately 1.4 degrees and the angle of the desired approach glide slope is 3 degrees. By demodulating the received glide slope signal and calculating the difference in depth of modulation (DDM) between the two tones, the ILS-GS provides the pilot with vertical course data [3].

Difference in depth of modulation (DDM) is the relative difference between the two AM carriers of 90 Hz and 150 Hz. If the DDM is a positive value, the upper 90 Hz beam is predominant, whereas if the DDM is a negative value, the lower 150 Hz beam is predominant. A pilot would need to exercise motor judgment to maintain enough power and approach angle for ideal vertical descent (DDM=0). The landing approach angle must also be corrected so that the aircraft landing will be “cushioned” by air upon touchdown and be within tolerances of the landing gear’s mechanical integrity.

2.2.2 Instrument landing system- localizer (ILS-LOC/LLZ)



Figure 12: ILS-LOC antenna

The localizer transmitter is located near the end of the runway (nearest to the start of the aircraft approach). Typically, horizontally aligned antennas transmit two intersecting main beams beside one another at carrier frequencies between 108 MHz and 112 MHz. As seen from the approaching aircraft coming in for a landing, the left beam is usually modulated at 90 Hz and the right beam at 150 Hz [3]. With careful field installation and maintenance, the received signal will be modulated equally along the centerline of the runway.

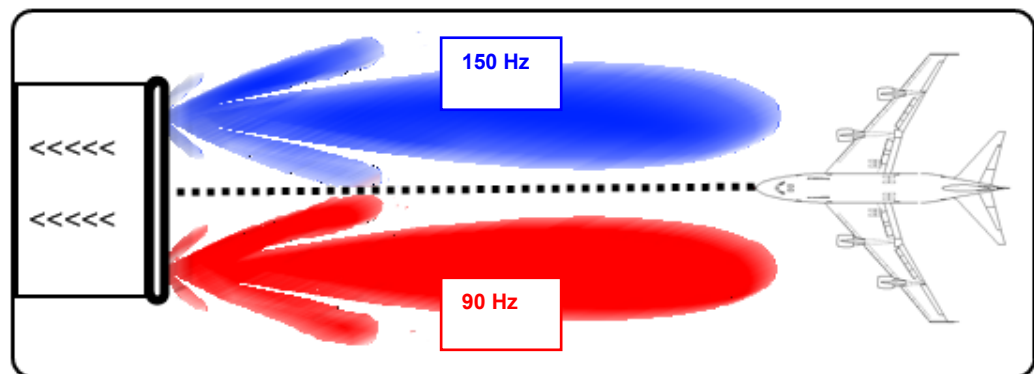

Figure 13: Difference in depth of modulation (DDM) for ILS-LOC/LLZ (plan view)

The total beam width is approximately 5 degrees, and the localizer receiver uses this modulation to determine the correct descent approach path. By demodulating the received localizer signal and calculating the difference in depth of modulation (DDM) between the two tones, the ILS-LOC/LLZ provides the pilot with lateral course data.

Difference in depth of modulation (DDM) is the relative difference between the two AM carriers of 90 Hz and 150 Hz. If the DDM is a positive value, the left 90 Hz beam is predominant, whereas if the DDM is a negative value, the right 150 Hz beam is predominant. A pilot would need good psychomotor skills to maintain the aircraft at an ideal lateral correction of $DDM=0$, especially when visibility is poor or in crosswinds. In some instances, adverse weather conditions brought about by crosswinds would require the pilot to bank the aircraft's nose towards the incoming wind, while keeping the undercarriage aligned towards the runway. This process is called "crab landing". Fortunately, accurate and reliable ILS-LOC/LLZ and ILS-GS systems are able to guide pilots even under poor visibility conditions or in adverse weather.

2.2.3 Marker beacon (MB)

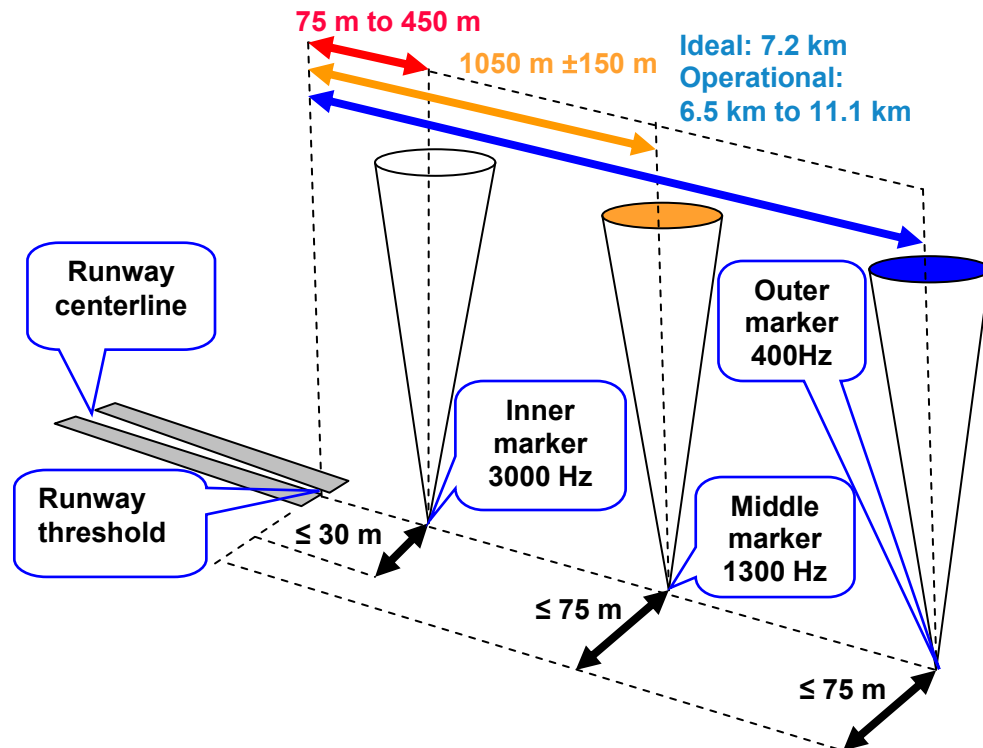

Figure 14: Marker beacon placement with respect to runway

Marker beacon (MB) receivers decode audio and provide signaling output to identify one of three marker beacons installed near the runway. The markers are placed as shown in Figure 14 above, in accordance with International Civil Aviation Organization (ICAO) Annex 10 Volume I Radio Navigation Aids.



Figure 15: Audio-video perception of marker beacons

Marker beacons transmit a narrow beam width at 75 MHz carrier frequency in a vertical direction, and each has a different distinct modulation code to allow the receiver to identify which one it is flying over. The pilot can determine which marker beacon was flown over either by visual identifying the color of the marker beacon or by listening to the audio tone. The outer marker beacon is modulated at 400 Hz, the middle marker beacon at 1300 Hz, and the inner marker beacon at 3000 Hz. The audio/visual pairing of marker beacons is as follows:

- Outer marker flashes BLUE in the cockpit at 400 Hz (“relaxed” tone).
- Middle marker flashes AMBER in the cockpit at 1300 Hz (“hurried” tone).
- Inner marker flashes WHITE in the cockpit at 3000 Hz (“urgent” tone).

2.3 Applications Overview

Table 2: R&S® portfolio of aeronautical radio navigation measurement solutions

Rohde & Schwarz instruments	Type	Options	Typical applications
R&S®SMA100A	Analog Signal Generator	SMA-K25 (VOR/ILS) SMA-K26 (DME)	Receiver tests in R&D, production and maintenance; Calibration of test equipment
R&S®NRP-Z81 in combination with R&S®SMA100A	Wideband Power Sensor	SMA-K26 (DME)	DME transponder tests
R&S®RTO/RTM	Oscilloscope	Base Unit	Verification of DME transponders in test laboratories
R&S®FSQ/FSU R&S®FSMR	Spectrum Analyzer Measuring Receiver	FS-K15, FS-K7 (MB) FS-K15, FS-K7 (MB)	R&D and production Calibration of VOR/ILS signals in avionics test labs
R&S®EVS300	ILS/VOR Modulation Analyzer	Base unit EVS-K2 (GPS receiver serial connection) EVS-K3 (CRS/CLR) EVS-K8 (DME with R&S®NRP-Z81 and R&S®NRP-Z4 USB adaptor)	Field runway measurements and usage in test laboratories
R&S®CMS57	Radiocommunication Service Monitor	Base unit	Transceiver test in service, maintenance and test departments

Rohde & Schwarz offers a complete portfolio of solutions (see Table 2) for the various aeronautical radio navigation signals discussed above.

Connecting the R&S®NRP-Z81 wideband power sensor to the analog signal generator provides the most convenient solution for DME transponder testing. The R&S®SMA100A analog signal generator equipped with the R&S®SMA-K26 DME option provides an independent T&M solution for referencing built-in test equipment (BITE) in DME stations. The R&S®SMA-K25 VOR/ILS option offers excellent signal quality with exceptional spectral purity, modulation accuracy, and repeatability. Setup is made simple with the flow diagram and structured menus in the graphical user interface (GUI). The R&S®NRP-Z81 wideband power sensor allows for accurate and portable DME pulse analysis with a R&S®NRP-Z4 USB adaptor. R&S®RTO/RTM oscilloscopes provide high signal fidelity for pulse-to-pulse analysis and even offer an FFT spectrum.

The R&S®FSMR with the R&S®FS-K15 avionics option allows for highly precise calibration of VOR/ILS signal generators and service monitors. The FSU and FSQ with the FS-K15 avionics option are dedicated to the development and manufacturing of the VOR/ILS infrastructure. When paired with the FS-K7 analog demodulation measurement option and the FSQ-K70 vector signal analysis option, they also allow analysis for voice and data communication applications.

Outdoor measurements include site maintenance and field runway measurements that require weather-resistant instruments that can run on a battery. These demands are met by the accurate, portable, and versatile R&S®EVS300 modulation analyzer.

The R&S®CMS57 provides service, maintenance, and test departments a versatile one-box solution for VOR/ILS and MB transceiver testing.

As shown before, Rohde & Schwarz provides solutions for both transmitter and receiver testing. For transmitter tests, care must be taken to attenuate the signal before RF input. For example, a typical spectrum analyzer has a typical RF input rating of +27 dBm, or an avionics modulation analyzer has a typical RF input rating of +13 dBm. For receiver tests, a signal generator with typically +20 dBm output power is sufficient for most requirements. Therefore, providing ample buffer for maximum input into the RF port is essential to protect the equipment from damage. A typical spectrum analyzer has the benefit of a wide dynamic range, with both weak signals (due to path loss) at just above the noise floor as well as high-powered signals (before transmission) being displayed. Typically, a powerful 30 dB attenuator with good heat dissipation in the HF, VHF, and UHF bands is preferred.

3 Application Scenarios

3.1 Receiver tests using the R&S[®] SMA100A signal generator

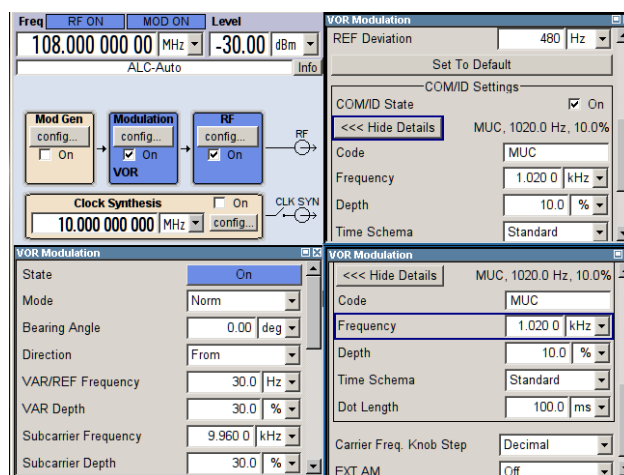
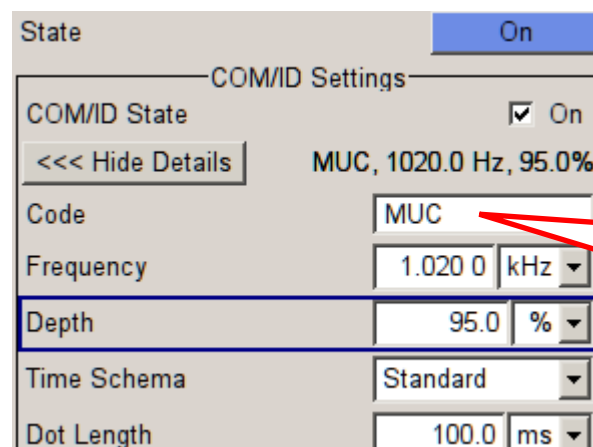

Figure 16: R&S[®] SMA-K25: VOR option is activated in the MODULATION section.

For aeronautical radio navigation receivers, the R&S[®] SMA-K25 VOR/ILS option offers high-precision, modulated VOR/ILS, ADF, MB signals, flexible parameter settings, including modulation depth and phases, and COM/ID identification [4].



**COMMUNICATION/
IDENTIFICATION (COM/ID)
airport call-sign of Munich
is "MUC" for example.**

Figure 17: User-defined COM/ID of "MUC" is automatically converted to Morse code using the R&S[®] SMA-K25.

The R&S[®] SMA-K25 VOR/ILS option allows the user to enter the alphanumeric symbols for the communication/identification (COM/ID) airport call-sign, which is automatically converted to Morse code as shown in Figure 17. No prior knowledge of Morse code is required.

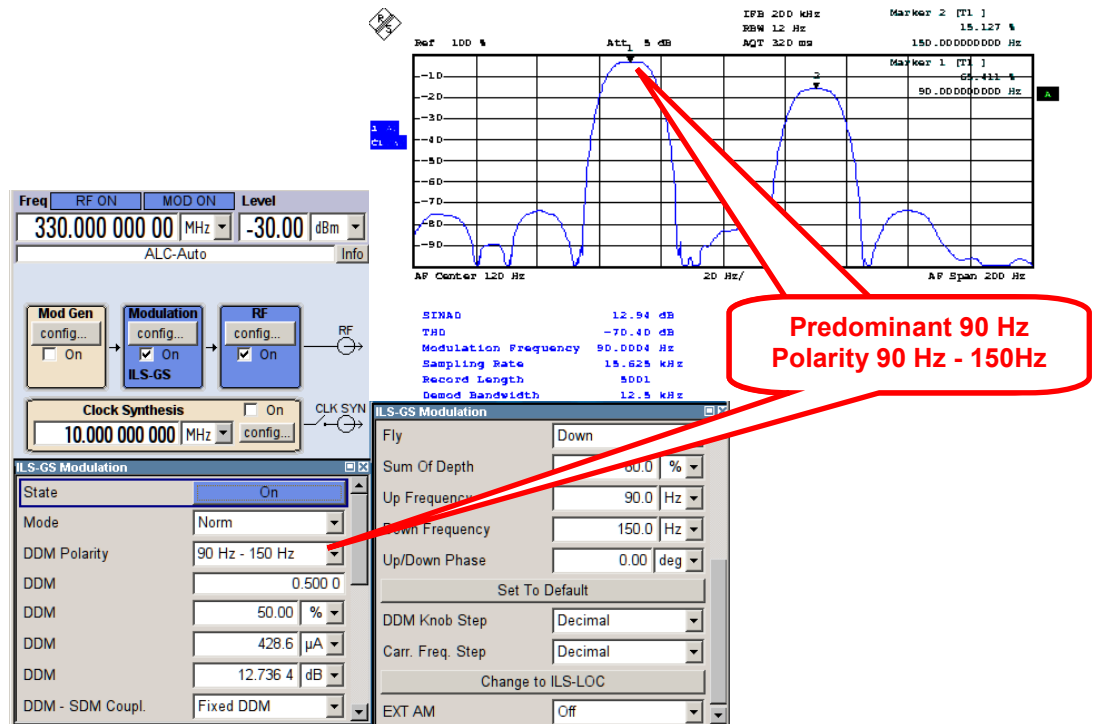

Figure 18: R&S[®]SMA-K25: The ILS-GS modulation parameter settings are shown. The ILS-GS AM 90 Hz - 150 Hz spectrum is illustrated using the R&S[®]FS-K7 analog demodulation.

The flexible parameter settings in the R&S[®]SMA-K25 VOR/ILS option make it possible to test parameters such as the difference in depth of modulation (DDM). As shown in Figure 18, a set DDM of 0.5 for the ILS-GS signal corresponds to a **predominant 90 Hz (left beam)**. The R&S[®]FS-K7 analog demodulation option is used in Figure 18 to illustrate the AF spectrum of this AM signal. The predominant 90 Hz AM signal is shown.

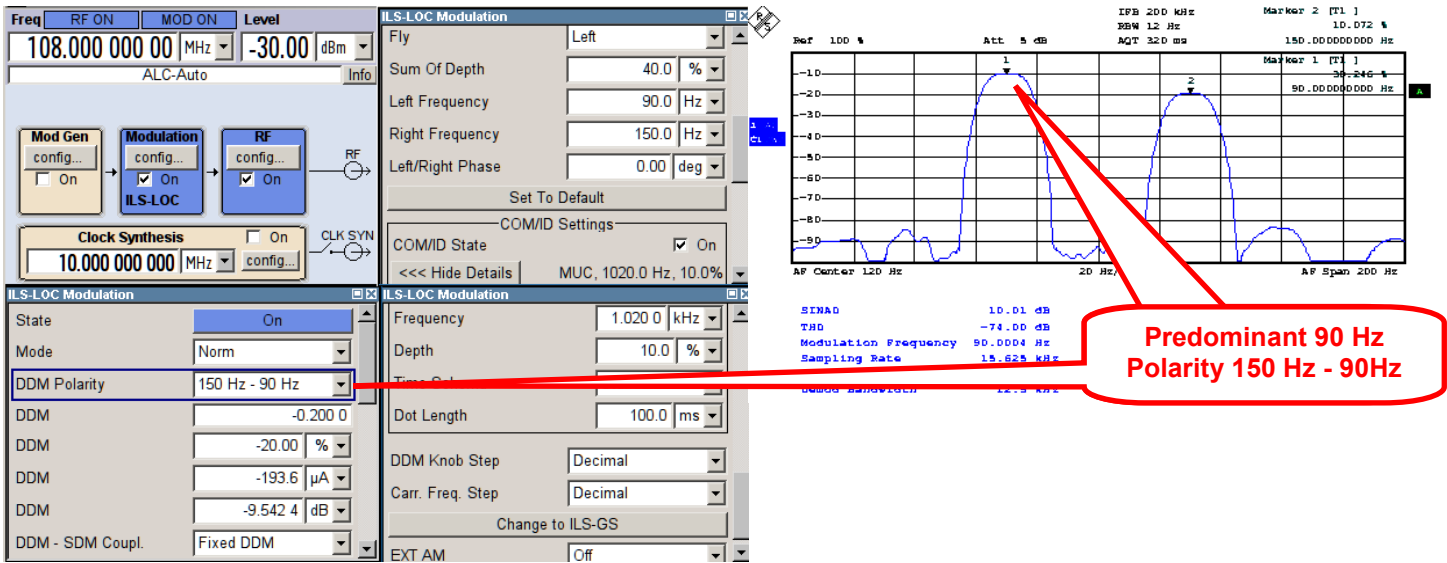

Figure 19: R&S[®]SMA-K25: The ILS-LOC modulation parameter settings are shown. The ILS-LOC AM 90 Hz - 150 Hz spectrum is illustrated using the R&S[®]FS-K7 analog demodulation (notice the flexibility in the DDM polarity).

A DDM of -0.2 for the ILS-GS signal corresponds to a predominant 90 Hz (left beam) corresponding to the R&S[®]SMA-K25 DDM polarity of 150 Hz - 90 Hz, as shown in Figure 19. The R&S[®]FS-K7 analog demodulation option is used in Figure 19 to illustrate the AF spectrum of this AM signal. The R&S[®]SMA-K25 assigns the carrier frequency dial settings in accordance with International Civil Aviation Authority (ICAO) recommendations. A crossover function makes it easy to toggle between ILS-LOC and ILS-GS without having to return to the main block module schematic.

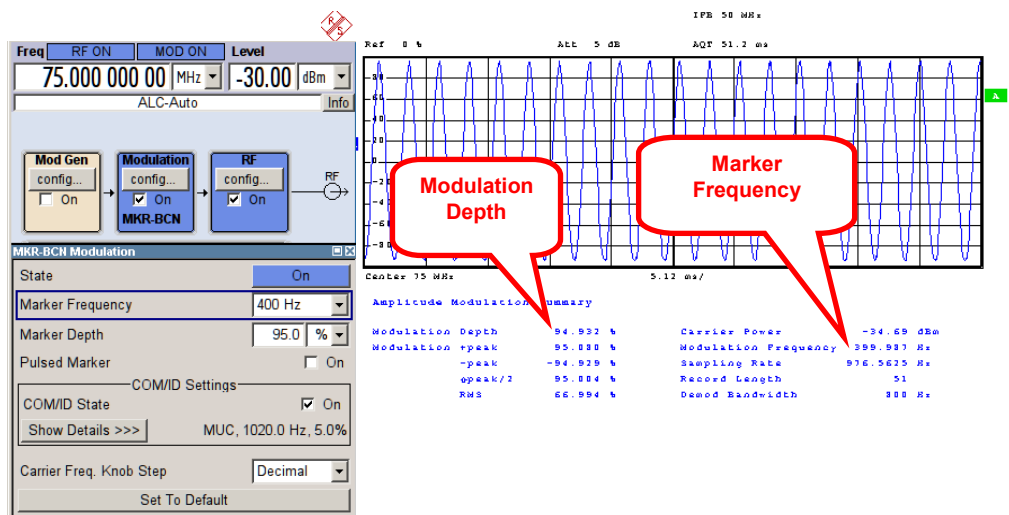

Figure 20: R&S[®]SMA-K25: MB AM modulation settings are shown. A modulation depth of 95 % at 75 MHz carrier frequency is set. The modulation depth at carrier frequency is illustrated using the R&S[®]FS-K7 analog demodulation.

Marker beacons (MB) utilize a 75 MHz carrier frequency with an AM modulation depth of 95 %. The Marker Frequency field is used to configure the outer marker (400 Hz), middle marker (1300 Hz), and inner marker (3000 Hz). Figure 20 shows an outer marker beacon set to 95 % AM depth as demodulated by the R&S®FS-K7 analog demodulation option.

The automatic direction finder (ADF) settings provided by the R&S®SMA-K25 VOR/ILS option are shown in Figure 21. The selected COM/ID of the signal is illustrated in the time-domain using R&S® spectrum/signal analyzers at ZERO SPAN. In Figure 21, each dash corresponds to 300 ms and each dot to 100 ms.

The ZERO SPAN allows for time-domain display corresponding to the MORSE-code COM/ID of "MUC".

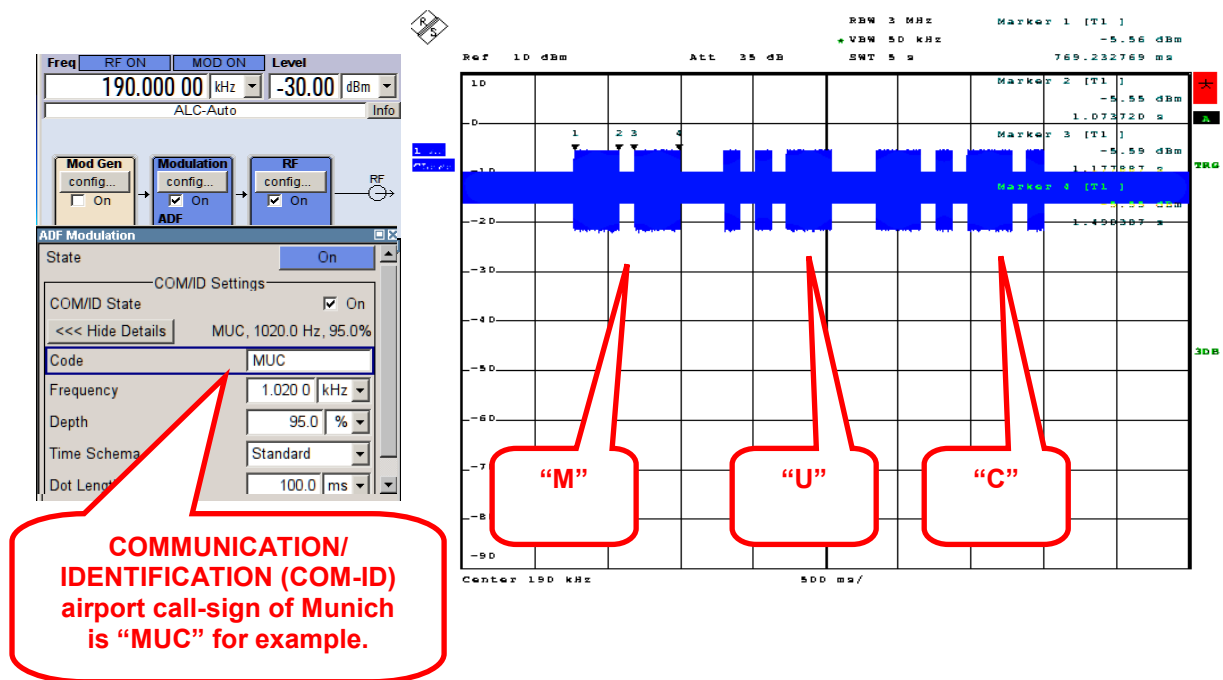

Figure 21: R&S®SMA-K25: ADF modulation settings are shown. The selected COM/ID of "M-U-C" is illustrated by a time-domain analysis of the signal.

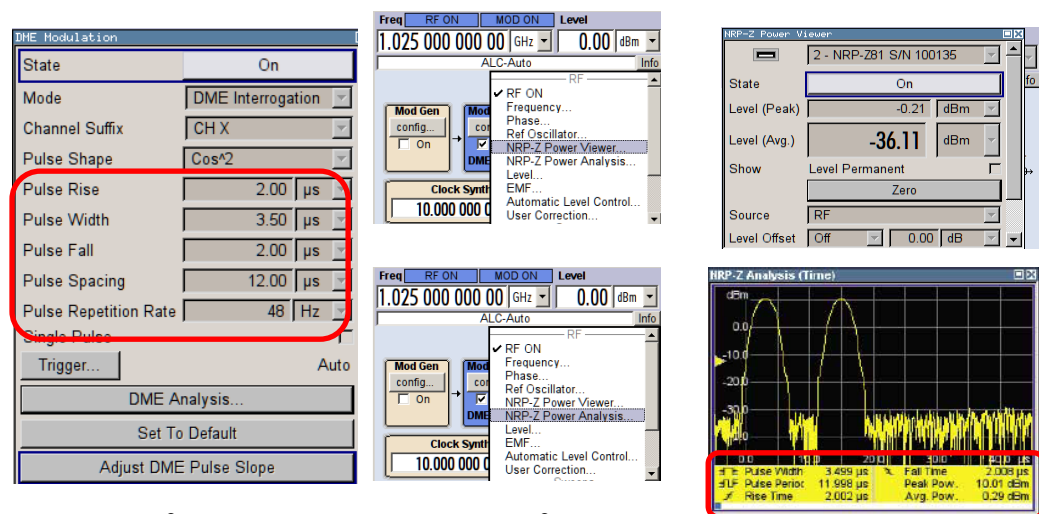

Figure 22: R&S®SMA-K26: DME generation and R&S®NRP-Z81 power sensor analysis using the R&S®SMA-K28

The R&S® SMA-K26 DME option makes it possible to select DME interrogate signals and to set deviations in order to allow for more robust testing. See [Application Note 1GP74](#) for details. The R&S® SMA-K26 DME option can be used to simulate a DME ground station or transponder; adding a R&S® NRP-Z81 wideband power sensor [5] and R&S® SMA-K28 power analysis software option makes it possible to analyze pulse parameters such as rise and fall times, pulse width, and pulse spacing automatically. When paired with these options, the R&S® SMA100A can generate and analyze time-domain characteristics of the DME pulses.

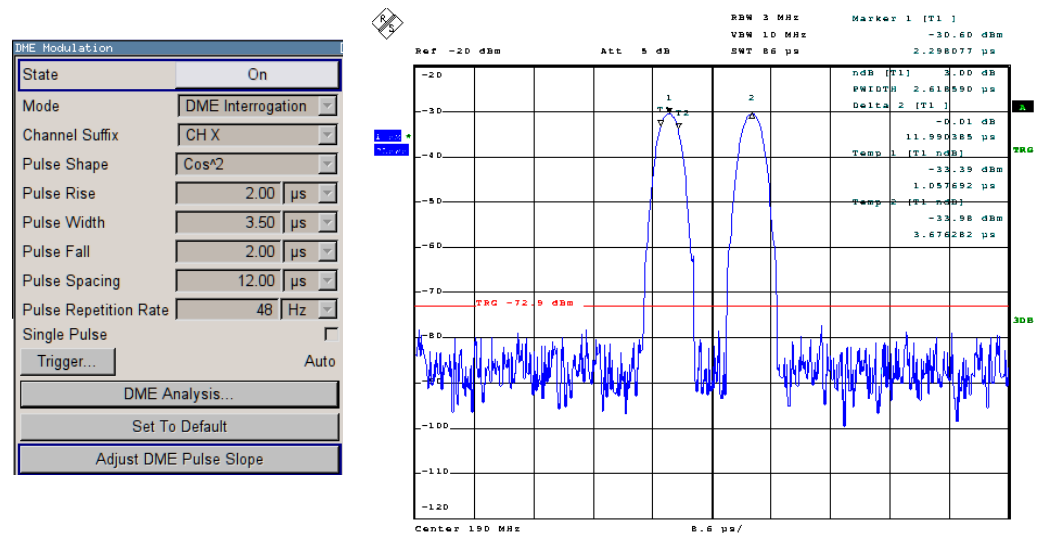

Figure 23: R&S® SMA-K26: DME generation and time-domain pulse width analysis using the R&S® FSQ

When operated without the R&S® SMA-K28 power analysis software option, R&S® spectrum/signal analyzers at ZERO SPAN are able to provide a time-domain analysis of the pulses.

However, for custom pulse shapes like DME pulses, using the R&S® NRP-Z81 wideband power sensor with the R&S® NRP-Z4 USB adaptor allows both time-domain analysis using the PC-based NRP Power Viewer Plus software and auto-detection of pulse parameters [5].

3.2 Calibration of VOR/ILS signal generators and service monitors using the R&S®FSMR measuring receiver



Figure 24: The R&S®FS-K15 avionics option for VOR/ILS transmitter testing installed in the R&S®FSMR measuring receiver.

The R&S®FS-K15 avionics option extends the capabilities of the R&S®FSMR measuring receiver to verify VOR and ILS signals from signal generators, such as the R&S®SMA or Collins, and from service monitors, such as the R&S®CMS57. Calibration of key parameters, including bearing for VOR signals and difference in depth of modulation (DDM), is highly precise and easily measured by the R&S®FS-K15 avionics option. Uncertainty for DDM measurement is 0.0002 DDM +1 % of reading; VOR bearing can be measured with an uncertainty of 0.03 and a resolution of 0.01. Together with the functions provided by the base unit, the R&S®FSMR calibrates signal generator parameters, such as frequency, absolute and relative level, modulation depth, frequency deviation, modulation frequency, and distortion. A good reference is provided at http://www2.rohde-schwarz.com/file_10726/FS-K15_dat_sw_en.pdf.

3.2.1 Measuring VOR signals using the R&S®FS-K15 option

In VOR measuring mode, the R&S®FS-K15 outputs a result summary that shows all relevant parameters at a glance. These include carrier frequency, signal level and modulation depth of 30 Hz VAR and REF modulation signals, deviation of the 9.96 kHz REF signal, COM/ID identification, and VOR bearing angle [6]. A **Course Deviation Indicator (CDI)** bar graph indicates the bearing angle. Both **FROM** and **TO** conventions are displayed so that they can be matched with the transmitter settings (see Fig. 25).

Alternatively, the modulation spectrum can be analyzed. For measurements on VOR transmitters, it is important to attenuate the transmitter power using suitable external attenuators to below +30 dBm. The VOR mode provides easy operation with the auto-tune and the auto-level function, which set the frequency and signal level automatically.

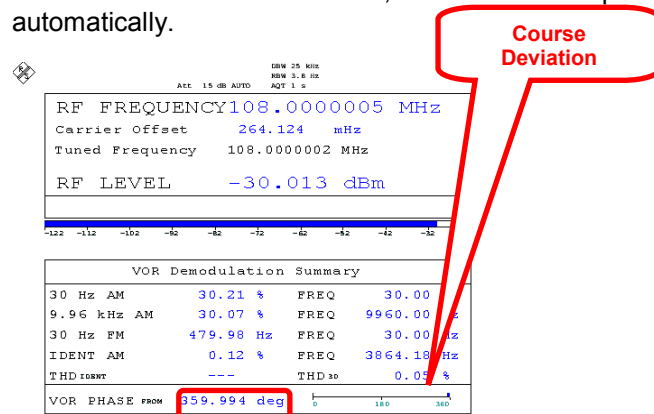

Figure 25: The R&S®FS-K15 avionics option in VOR measuring mode displays all relevant parameters of a VOR signal at a glance. Here the signal shows a bearing of 360° (FROM).

3.2.2 Measuring ILS signals using the R&S®FS-K15 option

Similar to VOR mode, the ILS measurement function provides a quick overview of all relevant parameters for the ILS signal in a result summary table. In addition to the RF parameters such as carrier frequency and level, these include the parameters for DDM, SDM, modulation depth and frequency of the 90 Hz and 150 Hz components, as well as the overall distortion (THD) related to the 90 Hz and 150 Hz components. A course deviation indicator (CDI) provides an analog view, which makes it easier to see trends when doing alignments.

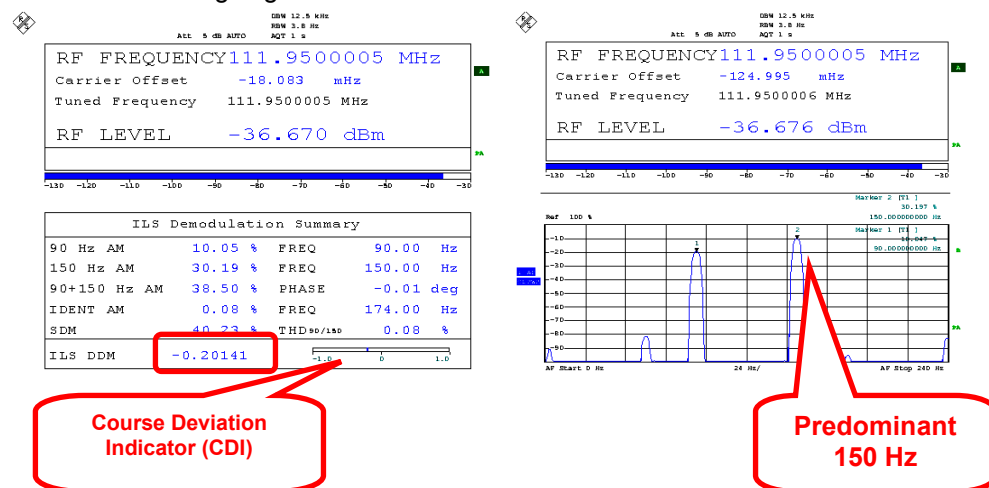

Figure 26: R&S®FS-K15: ILS AF spectrum with predominant 150 Hz modulation and -0.2 DDM.

The R&S®FS-K15 avionics option allows for both numeric result display and AF spectrum for intuitive graphic analysis. For example, a predominant 150 Hz resulting from a **DDM of -0.2** (as seen from the bar graph) is shown in the AF spectrum (see Figure 26). Simultaneous total harmonic distortion (THD) and selective distortion for K2/K3 distortions are also displayed. The course deviation indicator (CDI) is used to display DDM statistically for ILS parameters.

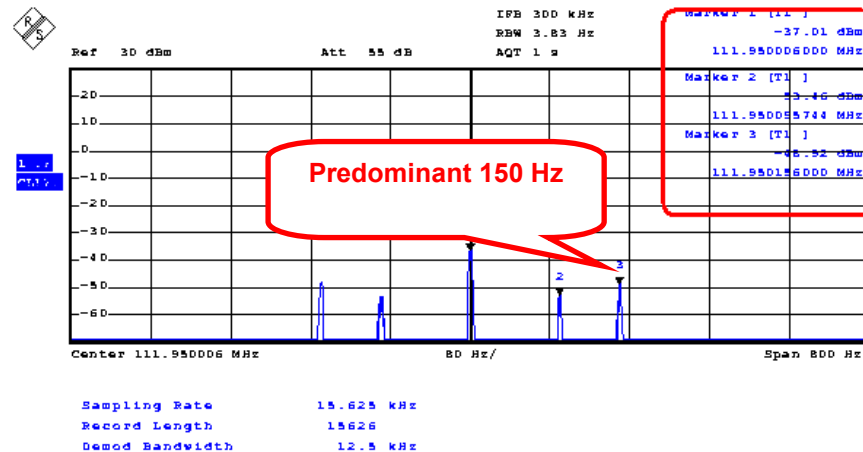

Figure 27: R&S®FS-K7 analog demodulation: ILS RF spectrum with carrier and predominant 150 Hz

The R&S®FS-K7 analog demodulation option allows for RF spectrum analysis inclusive of the carrier. The harmonic suppression can also be viewed. Figure 27 shows a view of the predominant 150 Hz and the DELTA markers corresponding to their AM depth. The R&S®FS-K7 analog demodulation can also be used to demodulate the AM-modulated marker beacon (MB) signals (see Figure 20).

3.3 Ground and flight inspection using the R&S®EVS300



Figure 28: The R&S®EVS300 modulation analyzer for field measurements

The R&S®EVS300 modulation analyzer makes it a relatively simple task to measure, display, and store data in the field. The EVS300 base unit ensures maximum level and modulation accuracy for VOR, ILS, and MB. Field measurements such as those in Figure 28 are possible day or night with the R&S®EVS-B3 nickel-metal hydride (NiMH) battery pack for up to 8 hours of continuous operating time, the R&S®EVS-Z1 weather-resistant shoulder bag, and the R&S®EVS-Z3 ILS/VOR dipole antenna.

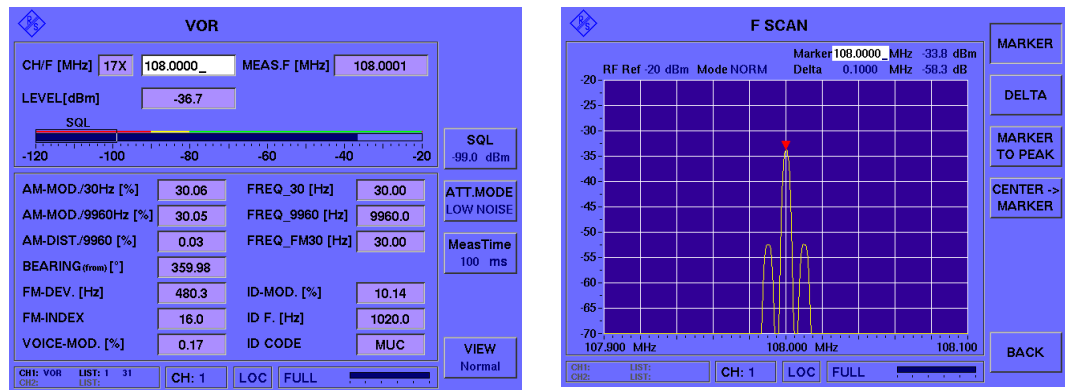

Figure 29: R&S®EVS300 VOR analysis and R&S®EVS-K1 FSCAN option displaying the RF spectrum

The R&S®EVS300, together with the R&S®EVS-K1 FSCAN option, provides CVOR/DVOR analysis of wanted and interfering signals, modulation depth and frequency measurements, AM distortion of the 9.96 kHz subcarrier, VOR bearing in degrees according to FROM or TO convention, FM deviation of the 9.96 kHz subcarrier, COM/ID decoding and frequency, and modulation depth of COM/ID, as shown in Figure 29. The R&S®EVS300 also provides flexible settings for ILS antenna, maintenance, and installation verification. DDM/SDM, frequencies, level, phase, and modulation depth can be analyzed using just the base unit. The R&S®EVS-K1 FSCAN and the R&S®EVS-K4 FFT are offered for spectral measurements, and the R&S®EVS-K7 SCOPE provides time-domain measurements. The R&S®NRT/NRP family of power sensors can measure power directly by means of a suitable external attenuator placed before the RF input (rated at +13 dBm). Advanced ILS measurements use the R&S®EVS-K3 CRS/CLR option for digital separation and clearance measurements on a single channel [7].

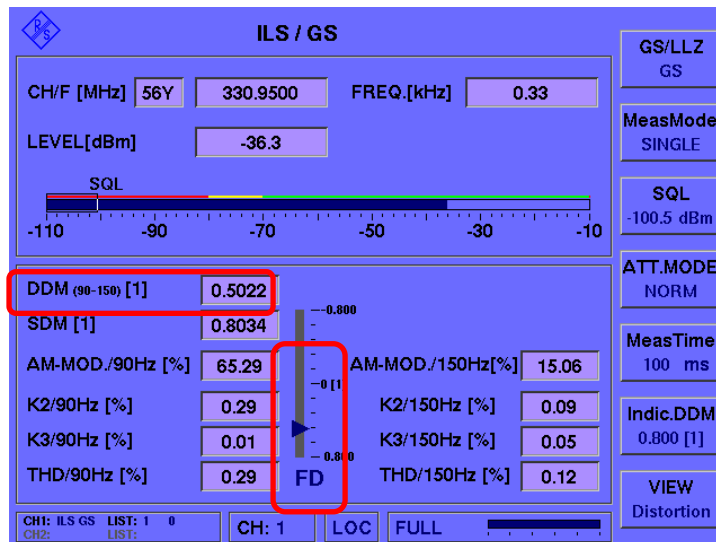

Figure 30: R&S®EVS300: ILS-GS statistical analysis with fly up/down cockpit DDM bar graph

The SETUP→OPTION allows the R&S®EVS300 modulation analyzer to be configured to display an intuitive cockpit for ILS/GS analysis. A DDM of 0.5 indicates a **90 Hz predominant (left beam) AM signal**, and a “fly down” (FD) is advised.

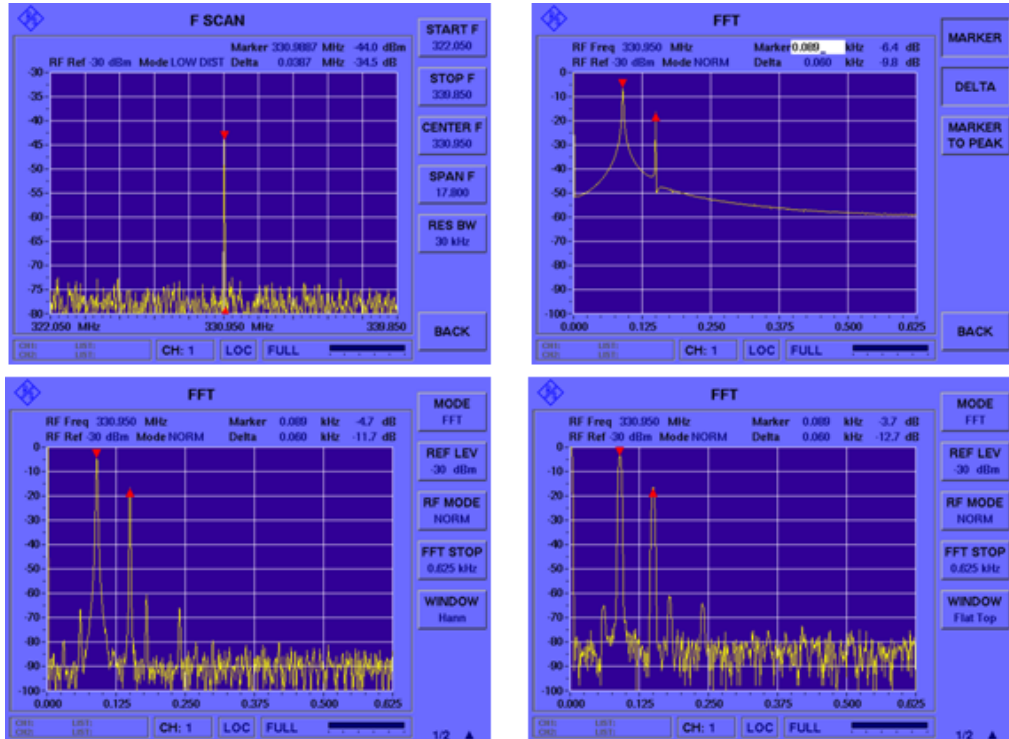

Figure 31: R&S®EVS-K1 FSCAN and R&S®EVS-K4 FFT (with no window, Hann, or flat top windows)

The R&S®EVS-K1 FSCAN allows for 70 MHz to 350 MHz spectral analysis with clear/write, average, and peak hold traces, as well as marker and delta marker. The R&S®EVS-K4 FFT option allows for no window, Hann or flat top windows. Figure 31 shows the predominant 90 Hz. Harmonics and intermodulation products can also be analyzed.

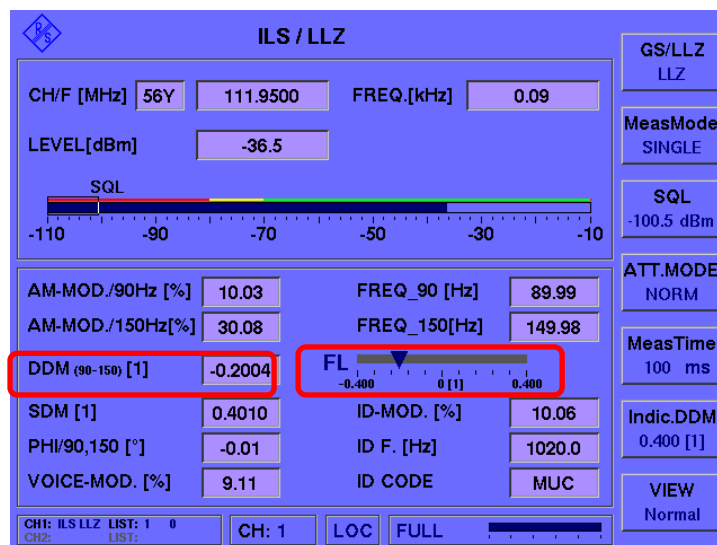

Figure 32: R&S®EVS300: ILS-LOC/LLZ statistical analysis with fly left/right cockpit DDM bar graph

For ILS/LOC or LLZ analysis, the DDM of -0.2 indicates a **150 Hz predominant (right beam) AM signal** and a “fly left” (FL) is advised. The R&S®EVS-B1 second signal processing unit makes simultaneous ILS-GS and ILS-LOC measurements possible. Two RF ports are utilized as channels 1 and 2. This simultaneous measurement doubles throughput and also provides real-time ILS measurements for both vertical (GS) and lateral (LOC) approach axes.

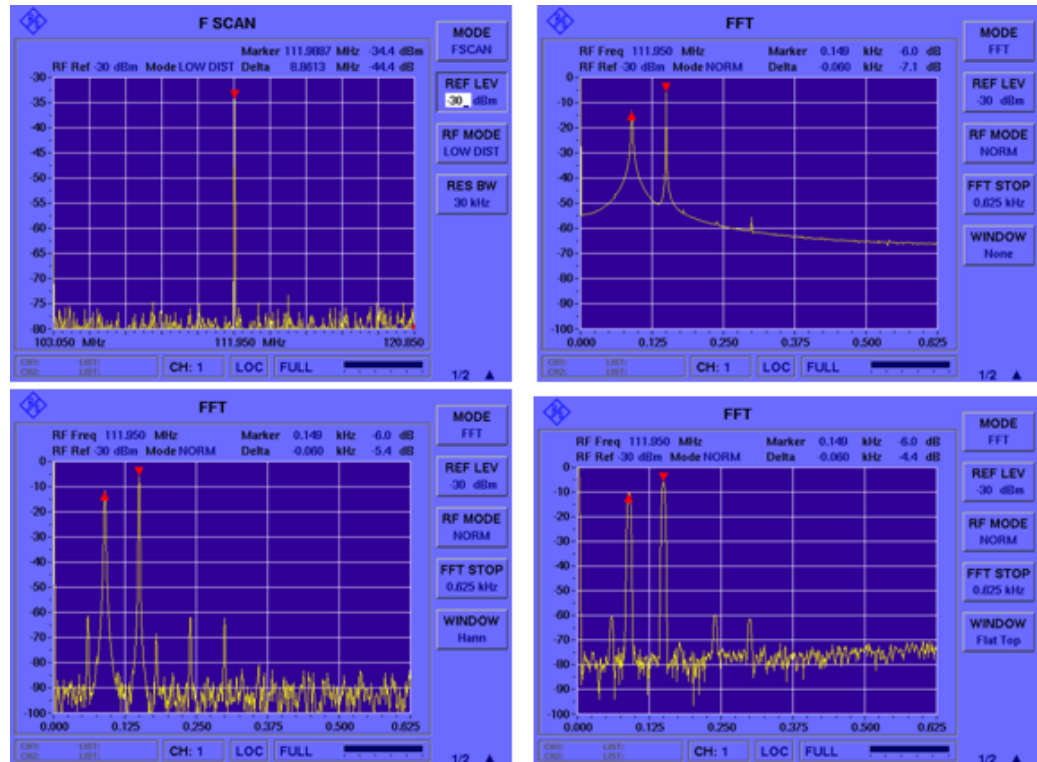

Figure 33: R&S EVS-K1 FSCAN and R&S®EVS-K4 FFT (with no window, Hann, or flat top windows)

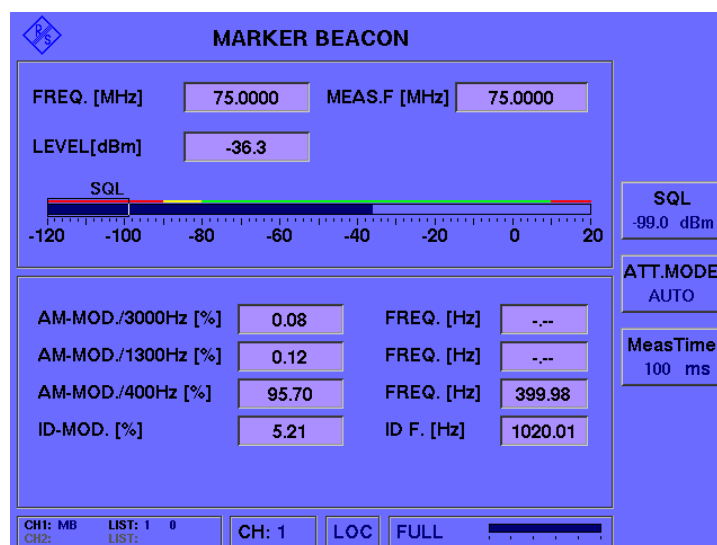

Figure 34: R&S®EVS300 marker beacon with AF audio output and squelch

Marker beacons are used to alert the pilot to check for descent altitude prior to touchdown. The three marker beacons – inner (3000 Hz tone), middle (1300 Hz tone) and outer (300 Hz tone) at 75 MHz carrier frequency – are located at specific intervals along the ILS approach and are identified by discrete audio and visual characteristics. The “decision height” is a specific altitude at which a missed approach must be initiated if the required visual references with the runway have not been established (e.g. ATC fails to report an obstacle on the runway, and the pilot aborts the landing after a visual inspection). The outer marker is used as the glide path intercept, the middle marker as the category I decision height (more than 60 m altitude, visibility more than 800 m, and minimum runway visual 550 m), and the inner marker as the category II decision height (from 30 m to 60 m altitude and minimum runway visual of 350 m) [8].

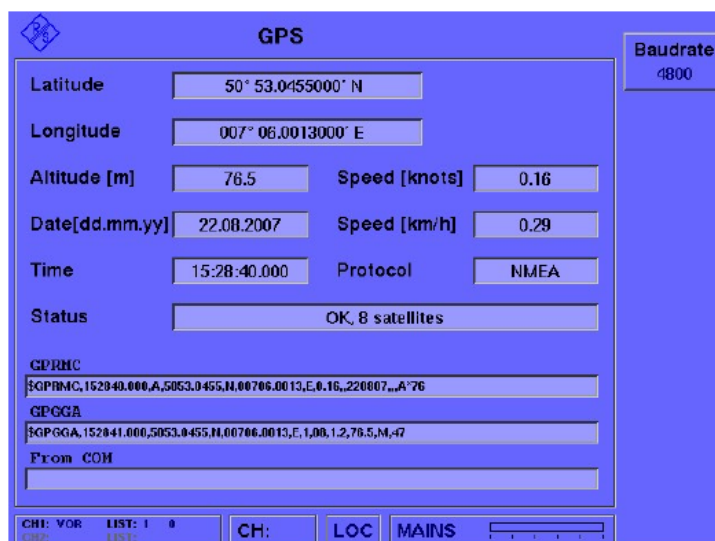

Figure 35: R&S®EVS-K2 GPS option with serial RS-232 connection to external GPS device

The R&S®EVS-K2 GPS option allows connection of external GPS devices via the second RS-232 interface. ILS/VOR/MB measurements correlate the measurement and positional data, which is then automatically time-stamped into a data set for test reports.

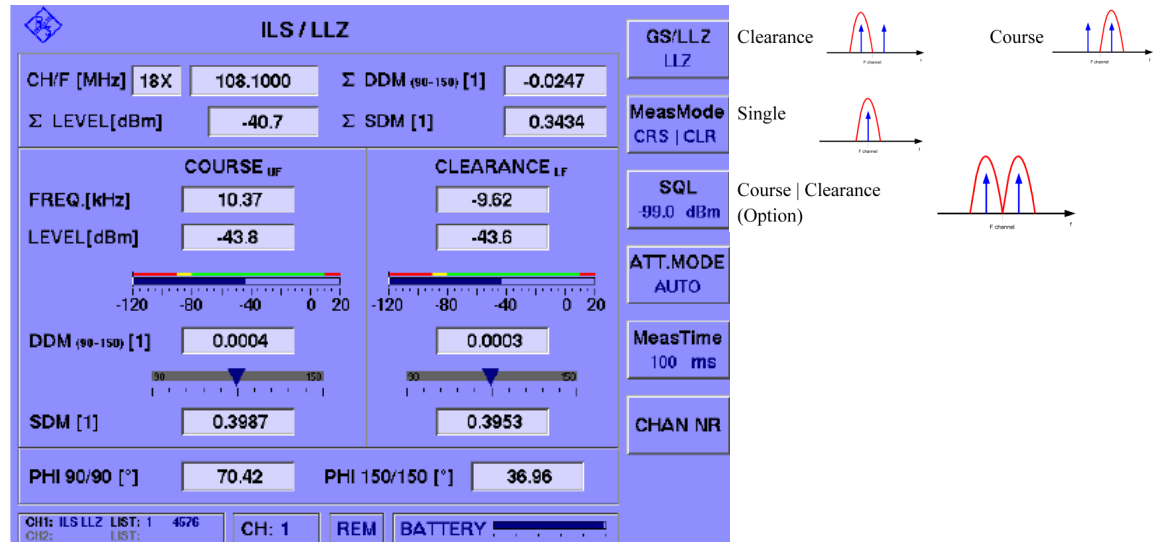

Figure 36: R&S®EVS-K3 course/clearance (CRS/CLR) mode and graphical depiction

The R&S®EVS-K3 option allows digital separation of course and clearance signals using only one signal processing channel. The level ratio and phase relationship between course and clearance can be precisely measured in the normal ILS system mode of operation.

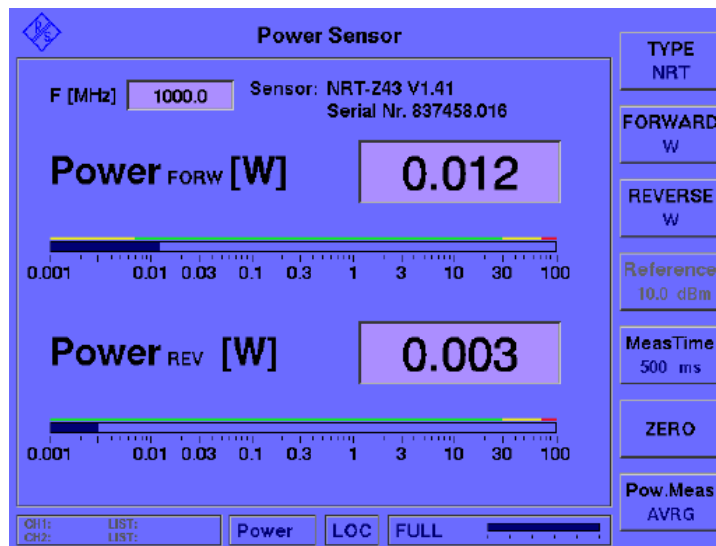

Figure 37: R&S®EVS-K5 power sensor option (R&S®NRP/T-Zxx power sensors)

The R&S®EVS-K5 power sensor option can be used to connect the R&S®NRT and NRP power sensors via the USB or RS-232-C interface. These power sensors, which can display values as either peak or average power, make it possible to field test and maintain transmitters. The R&S®NRT power sensor additionally allows the impedance mismatch to be measured on the Voltage Standing Wave Ratio (VSWR) tab, under Reverse Power.

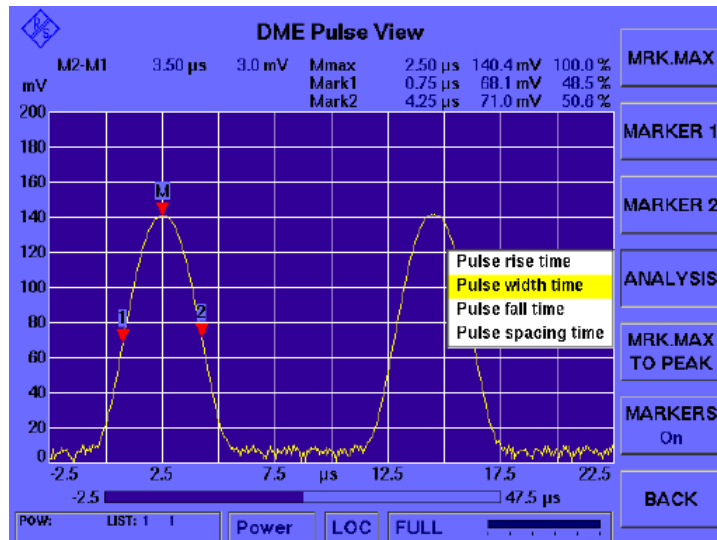

Figure 38: R&S®EVS-K6 DME option for use with EVS-K5 power sensor option

The R&S®EVS-K6 DME pulse shape view and the R&S®NRP-Z81 wideband power sensor make it easy to verify DME pulse parameters, such as pulse shape, rise time, fall time, pulse spacing, peak power output, peak variations, and time delay. The trigger delay can additionally be measured via the trigger input of the R&S®NRP-Z3 USB adaptor. The R&S®EVS-K5 and the R&S®EVS-K6 can be bundled as a package option in the R&S®EVS-K8.

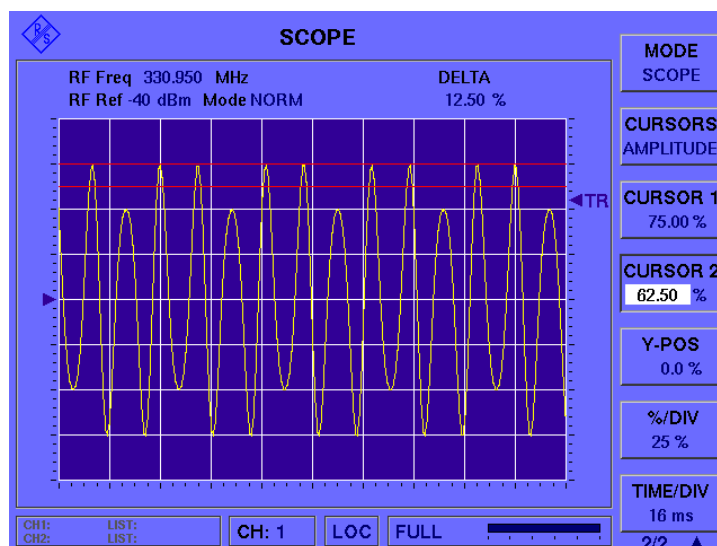

Figure 39: R&S®EVS-K7 oscilloscope option

The R&S®EVS-Z10 stand-alone calibration test system allows customers with numerous R&S®EVS300 units to calibrate their equipment and produce test reports, while avoiding customs duties and shipping time. The R&S®EVS-Z10 test system consists of the R&S®SMA100A signal generator, the R&S®FMAV modulation analyzer or R&S®FSMR receiver, and the R&S®RSG step attenuator. The R&S®FS-K15 is the successor to the R&S®FMAV. Additional information regarding the R&S®EVS-Z10 stand-alone calibration test system is available at http://www2.rohde-schwarz.com/file_11859/EVS-Z10_fly_en.pdf

3.4 Transceiver service testing using the R&S®CMS57



Figure 42: R&S®CMS57 radiocommunication service monitor

The built-in generator and receiver on the R&S®CMS57 radiocommunication service tester make it suited for service, maintenance, and testing of transceivers [9]. For transmitter testing, the R&S®CMS57 acts as an analog receiver that demodulates signals, such as VOR, ILS, and MB. The RF input rating of +13 dBm means that the power from the transmitter must be attenuated. The R&S®CMS57 provides a high-precision, built-in VOR/ILS generator for receiver testing.

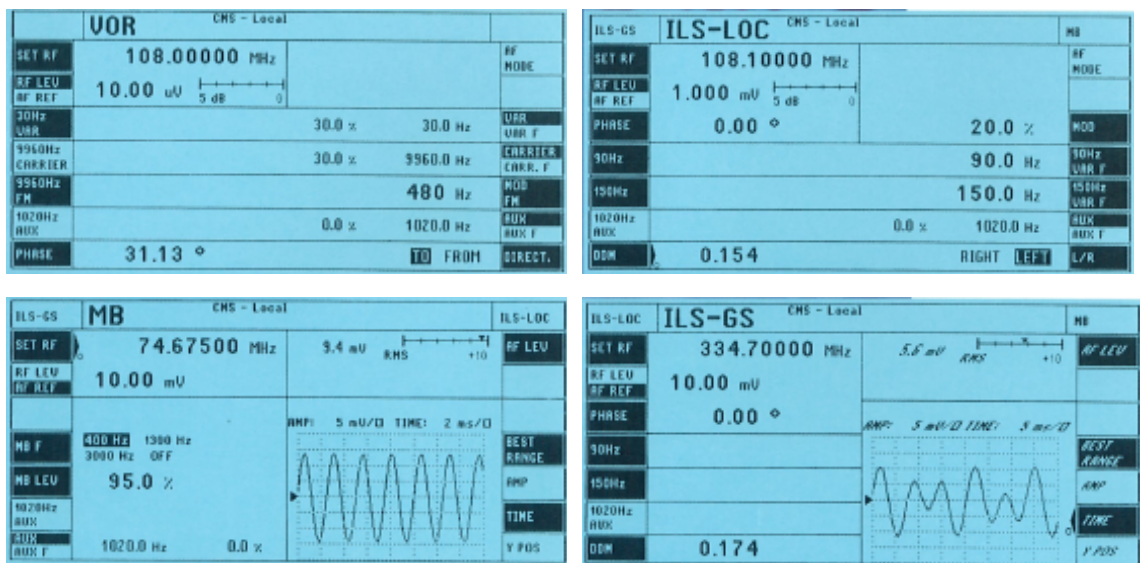

Figure 43: R&S[®]CMS57 generation and analysis of VOR, ILS, and MB signals

As seen in Figure 43, the difference in depth of modulation (DDM) steps of 0.001 for ILS, 0.01 degree steps for VOR, oscilloscope view for demodulated signals, and signal generation of MB ensure that the R&S[®]CMS57 radiocommunication service tester is the one-box solution for service and maintenance for aeronautical radio navigation signals.

3.5 DME pulse analysis using the R&S® RTO oscilloscope



Figure 44: R&S® RTO1024 2 GHz, 4-channel digital oscilloscope

The R&S® RTO digital oscilloscope (see Figure 44) combines excellent signal fidelity, a high acquisition rate, and a pioneering real-time digital trigger system within the 1/2 GHz class. Basic analog modulation schemes, like AM and FM, can also be viewed.

DME signals (see Figure 45) can be characterized with the R&S®RTO1022 (2 GHz, 2 channels) or the R&S®RTO1024 (2 GHz, 4 channels) digital oscilloscope. Parameters such as pulse rise/fall time, pulse width, and spacing are verified using multiple cursors, and the FFT spectrum can be displayed.



Figure 45: R&S®RTO digital oscilloscope with DME pulse analysis and FFT spectrum.

4 Conclusion

R&S® SMA100A analog signal generators equipped with the R&S® SMA-K25 VOR/ILS option provide precise signals for VOR/ILS, MB, and ADF receiver testing. The R&S® SMA100A, with a special R&S® SMA-K25 VOR/ILS option to maximize its testing portfolio, provides a versatile analog signal generator for calibration and measurement laboratories. The R&S® SMA-B46 option additionally provides a high-altitude capability compliant with MIL-PRF-28800 F. The R&S® SMA-K28 power viewer option allows for DME pulse profile analysis.

For laboratory development and calibration of VOR/ILS transmitters, the R&S® FS-K15 avionics option permits VOR/ILS demodulation using the R&S® FSQ and R&S® FSU signal/spectrum analyzers and the R&S® FSMR measuring receivers. The R&S® FS-K7 analog demodulation option allows for MB demodulation analysis in the R&S® FSQ and R&S® FSU signal/spectrum analyzers.

Precise level and modulation analysis for ground and flight inspection of VOR, ILS, MB, and DME transmitters is a specialized task performed by the R&S® EVS300. Various accessories, such as the R&S® EVS-B3 NiMH battery pack for up to 8 hours continuous operating time, the R&S® EVS-Z1 weather-resistant shoulder bag, and the R&S® EVS-Z3 ILS/VOR dipole antenna, make field measurements relatively simple. The R&S® EVS-Z10 test system allows airport authorities with numerous R&S® EVS300 instruments to perform their own calibrations, thus reducing down-time.

The R&S® CMS57 radiocommunications service tester offers calibration laboratories a versatile one-box solution for VOR, ILS, and MB transceiver testing.

Depending on the DME carrier frequency, a 2 GHz R&S® RTO digital oscilloscope is sufficient for DME pulse analysis. Basic analog modulation schemes used in aeronautical radio navigation, such as AM and FM, can also be analyzed in time-domain sinusoidal representation using the R&S® RTO digital oscilloscope.

5 References

- [1] Application Note 1GPAN10E, VOR-Receiver Tests using Signal Generator SMT
- [2] Application Note 1GPAN11E, ILS-Test Procedures using Signal Generator SMT
- [3] Application Note 1GPAN09E, VOR-ILS Testing using Signal Generator SMT
- [4] http://www2.rohde-schwarz.com/file_10970/MILNews10_2007_SMA100A.pdf
- [5] http://www2.rohde-schwarz.com/file_6981/Manual_NRP_Z81_Rev_02.pdf
- [6] http://www2.rohde-schwarz.com/file_8350/FS-K15_e.pdf
- [7] http://www2.rohde-schwarz.com/en/products/test_and_measurement/spectrum_analysis/EVS300-%7C-Manuals-%7C-22-%7C-700.html
- [8] Annex 10, Volume I Radio Navigation Aids, ICAO, pp. 317-318
- [9] http://www2.rohde-schwarz.com/file_7847/CMS_bro_en_v05.pdf

6 Abbreviations

Abbreviation	Actual
VOR	Very High Frequency Omni-Directional Radio Range
ILS-GS	Instrument Landing System- Glide Slope
ILS-LOC/LLZ	Instrument Landing System- Localizer
MB	Marker Beacon
DME	Distance Measurement Equipment
TACAN	Tactical Air Navigation
MLS	Microwave Landing Systems
SSR	Secondary Surveillance RADAR
TCAS	Traffic Collision Avoidance System
VHF	Very High Frequency
UHF	Ultra High Frequency
HF	High Frequency
SATCOM	Satellite Communications
RADAR	Radio Detection and Ranging
GPS	Global Positioning System
ADF	Automatic Direction Finder
DOA	Direction-of-Arrival
ATC	Air Traffic Control
AM	Amplitude Modulation
CSB	Carrier-plus-Sideband
SBO	Suppressed-Carrier-Sideband Only
THD	Total Harmonic Distortion
DDM	Difference in Depth of Modulation
SDM	Sum of Depth of Modulation
ICAO	International Civil Aviation Organization
BITE	Built-In-Test-Equipment
CDI	Course Deviation Indicator
CRS/CLR	Course/Clearance
COM/ID	Communications/Identification

7 Ordering Information

R&S® Signal Generator

Designation	Type	Order No.
Analog Signal Generator	R&S® SMA100A	1400.0000.02
RF Path (9 kHz to 3 GHz, with electronic attenuator)	R&S® SMA-B103	1405.0209.02
RF Path (9 kHz to 6 GHz, with electronic attenuator)	R&S® SMA-B106	1405.0809.02
RF Path (9 kHz to 3 GHz, without attenuator)	R&S® SMA-B103L	1405.0609.02
RF Path (9 kHz to 6 GHz, without attenuator)	R&S® SMA-B106L	1405.1005.02
VOR/ILS Modulation	R&S® SMA-K25	1405.3008.02
DME Modulation	R&S® SMA-K26	1405.3408.02
Power Analysis	R&S® SMA-K28	1405.3950.02

R&S® Signal/Spectrum Analyzer and Measuring Receiver

Designation	Type	Order No.
Spectrum Analyzer 20 Hz to x GHz	R&S® FSU	1166.1660.0x
Signal Analyzer 20 Hz to x GHz	R&S® FSQ	1155.5001.0x
Measuring Receiver 20 Hz to x GHz	R&S® FSMR	1166.3311.0x
Analog (AM/FM/PM) Demodulation	R&S® FS-K7	1141.1796.02
VOR/ILS Measurement Demodulator	R&S® FS-K15	1302.0936.02
Signal Analyzer 9 kHz to x GHz	R&S® FSV	1307.9002.0x

R&S® Power Sensor for DME pulse analysis

Designation	Type	Order No.
Wideband Power Sensor	R&S® NRP-Z81	1137.9009.02
USB Adapter (passive)	R&S® NRP-Z4	1146.8001.02

R&S® VOR/ILS Modulation Analyzer

Designation	Type	Order No.
ILS/VOR Analyzer	R&S® EVS300	3544.4005.02
Second Signal Processing Unit	R&S® EVS-B1	5200.6625.02
GSM Modem	R&S® EVS-B2	5200.6631.02
Battery Pack	R&S® EVS-B3	5200.8240.02
Frequency Scan	R&S® EVS-K1	5200.6554.00
GPS Mode	R&S® EVS-K2	5200.6548.00
CRS/CLR Mode	R&S® EVS-K3	5200.9082.00
FFT Mode	R&S® EVS-K4	5201.5922.00
Support of Rohde&Schwarz power sensors	R&S® EVS-K5	5201.8644.02
DME Pulse Shape View	R&S® EVS-K6	5201.8650.02
Oscilloscope Mode	R&S® EVS-K7	5201.8667.02
R&S® EVS-K5 + R&S® EVS-K6 Package	R&S® EVS-K8	5201.8696.02
Weather Protection Bag	R&S® EVS-Z1	5200.5812.00
ILS/VOR Test Antenna	R&S® HF108	4061.0506.02
Test System for R&S® EVS300	R&S® EVS-Z10	5201.7777.02

R&S® Radiocommunications Service Monitor with VOR/ILS generator

Designation	Type	Order No.
Radiocommunications Service Monitor	R&S® CMS57	0840.0009.57

R&S® RTO Digital Oscilloscope

Designation	Type	Order No.
Digital Oscilloscope, 1 GHz 2 Channels	R&S® RTO1012	1304.6002.12
Digital Oscilloscope, 1 GHz 4 Channels	R&S® RTO1014	1304.6002.14
Digital Oscilloscope, 2 GHz 2 Channels	R&S® RTO1022	1304.6002.22
Digital Oscilloscope, 2 GHz 4 Channels	R&S® RTO1024	1304.6002.24
OCXO, accurate 10 MHz reference	R&S® RTO-B4	1304.8305.02
GPIB Interface	R&S® RTO-B10	1304.8311.02
Hard Disk for exchange including firmware	R&S® RTO-B19	1304.8328.02
Memory Upgrade, 50 Msample per channel	R&S® RTO-B101	1304.8411.02
Memory Upgrade, 100 Msample per channel	R&S® RTO-B102	1304.8428.02

About Rohde & Schwarz

Rohde & Schwarz is an independent group of companies specializing in electronics. It is a leading supplier of solutions in the fields of test and measurement, broadcasting, radiomonitoring and radiolocation, as well as secure communications. Established more than 75 years ago, Rohde & Schwarz has a global presence and a dedicated service network in over 70 countries. Company headquarters are in Munich, Germany.

Environmental commitment

- Energy-efficient products
- Continuous improvement in environmental sustainability
- ISO 14001-certified environmental management system



Regional contact

Europe, Africa, Middle East

+49 89 4129 123 45

customersupport@rohde-schwarz.com

North America

1-888-TEST-RSA (1-888-837-8772)

customer.support@rsa.rohde-schwarz.com

Latin America

+1-410-910-7988

customersupport.la@rohde-schwarz.com

Asia/Pacific

+65 65 13 04 88

customersupport.asia@rohde-schwarz.com

This application note and the supplied programs may only be used subject to the conditions of use set forth in the download area of the Rohde & Schwarz website.

R&S® is a registered trademark of Rohde & Schwarz GmbH & Co. KG. Trade names are trademarks of the owners.

Rohde & Schwarz Regional Headquarters Singapore Pte. Ltd.

10, Changi Business Park Central 2, #06-01/08

Singapore 486030

www.rohde-schwarz.com