

High Energy Density Capacitors for Military Applications

David A. Evans

Evans Capacitor Company

72 Boyd Avenue

East Providence, RI 02914

401-435-3555

devans@evanscap.com

*Presented to the Conference on the Commercialization of
Military and Space Electronics, Los Angeles, CA Feb. 7-10, 2005*

Electrolytic Capacitor Model

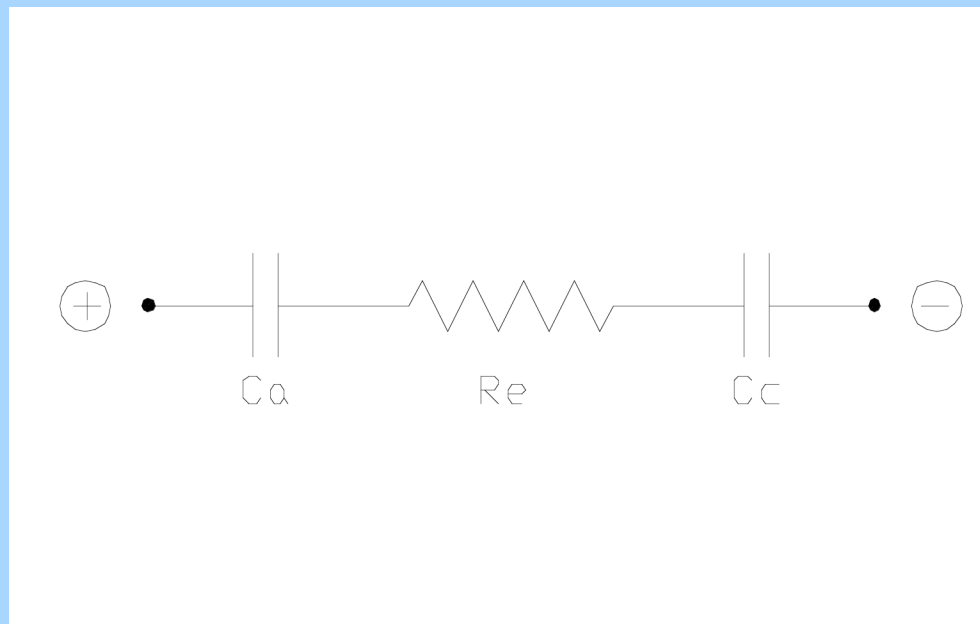

Hybrid Principle

- combines dielectric anode with redox cathode
- high voltage anode
- high capacitance cathode
- cathode volume is very small

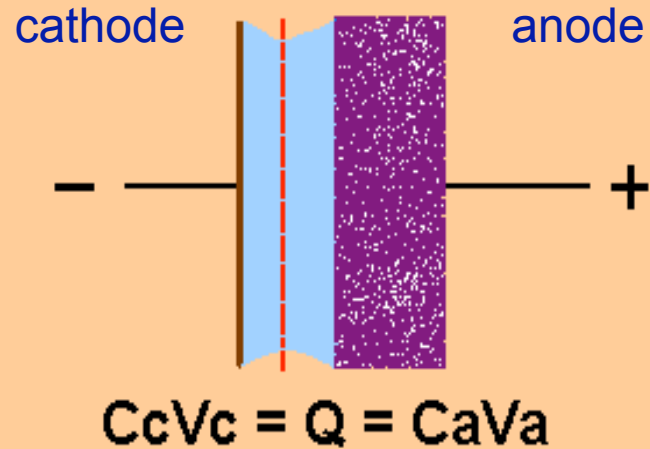

increases energy density two ways

Cell Voltage Balance

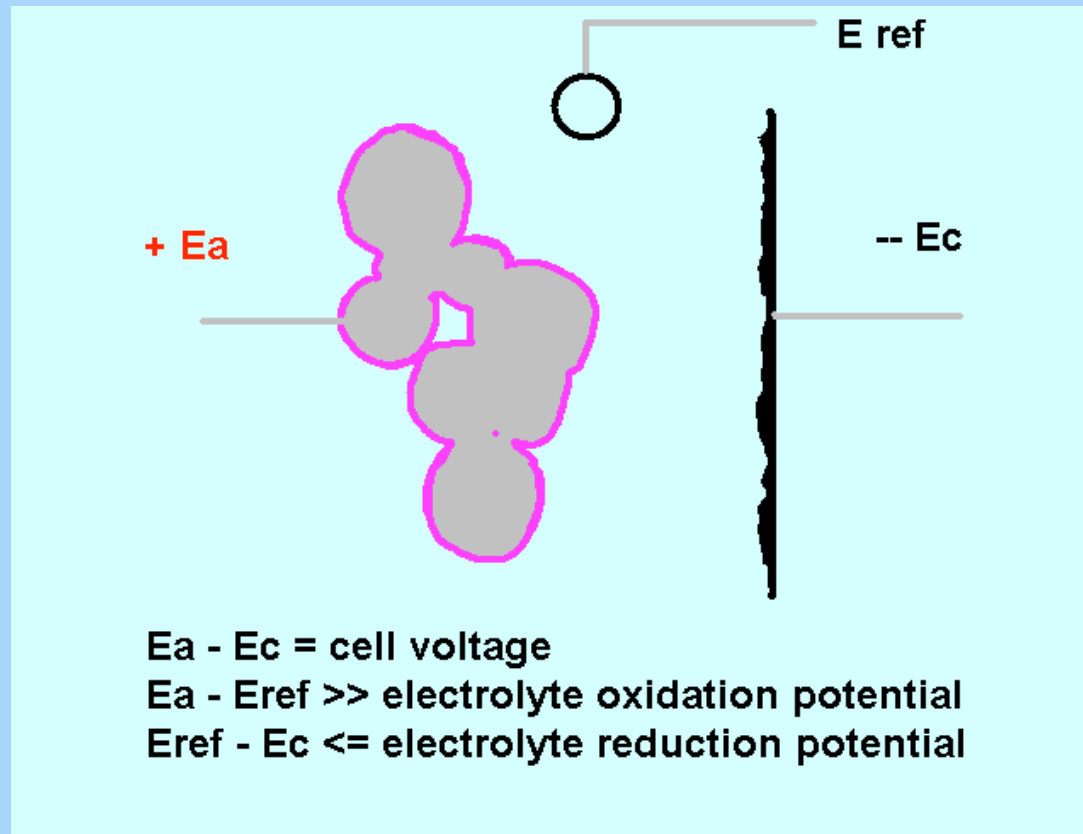

Partially Disassembled View



THQA2 Construction

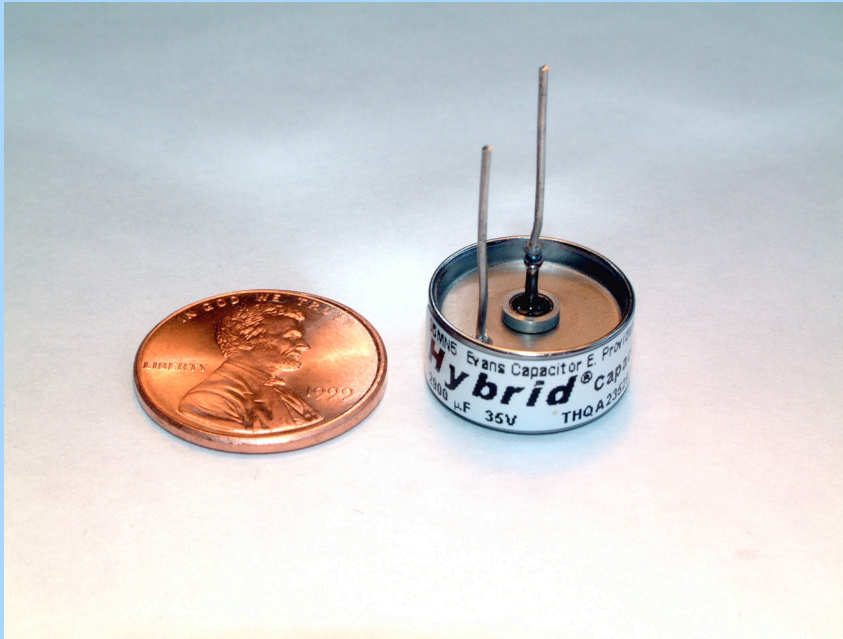

GLASS - METAL SEAL -
HERMETIC SEAL -
TEFLON SPACER -
TANTALUM ANODE -
SEPARATOR (2) -
CATHODE FOIL (2) -

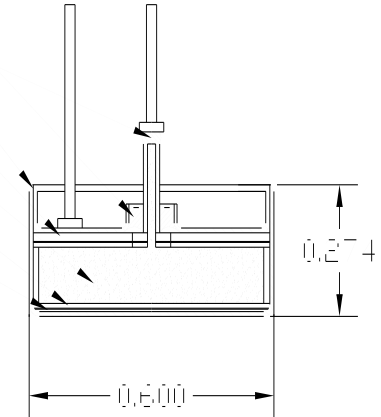

THQ1/3 Construction

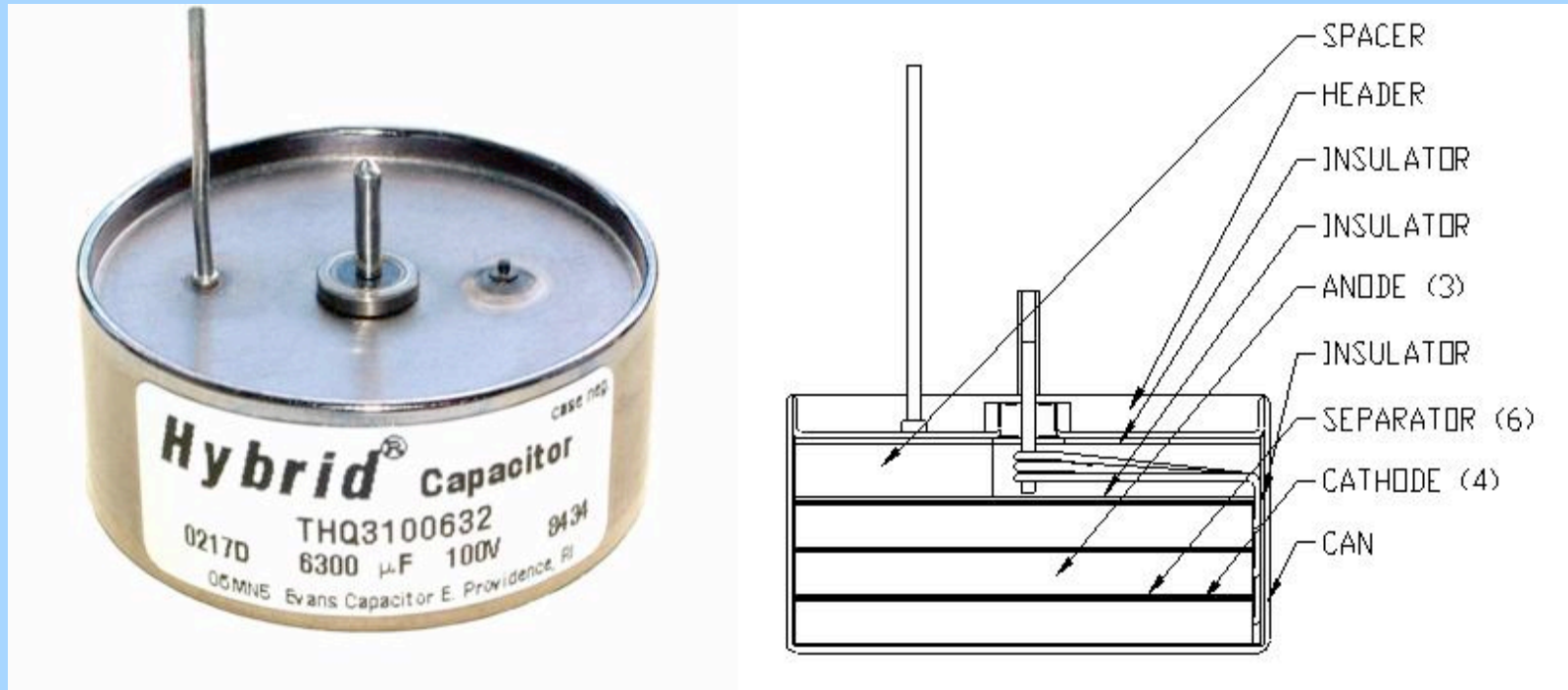

- THQ1 1.40 diameter X 0.31 long (inches)
- THQ3 1.40 diameter X 0.61 long

Energy Density Comparison

Type	WVDC	Cap	Ratio	Capacitance Density		
	Volts	uF		uF/cc	uF/g	uF/\$
MIL-C-39026	50	680	1	354	46	14
DSCC-04005	50	1500	2.2	1904	195	13
DSCC-04001	50	8000	12	1017	195	32
DSCC-04003	50	24000	35	1565	296	62
MIL-C-39018	50	8200	12	79		>1000

- 4X higher energy density than MIL-C-39026 extended range tantalum wet
- >10X higher energy density than MIL-C-39018 aluminum electrolytic

Power Hold-up

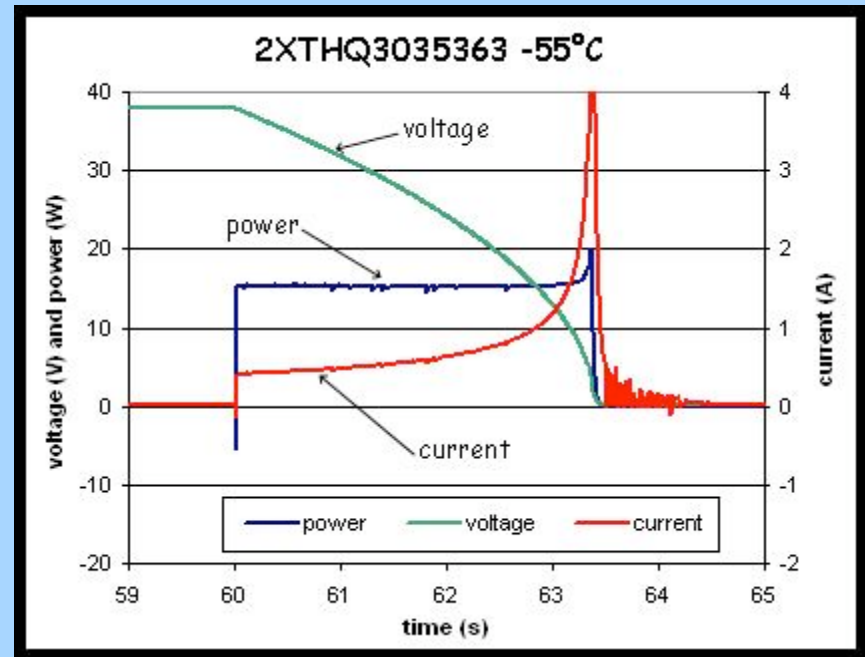
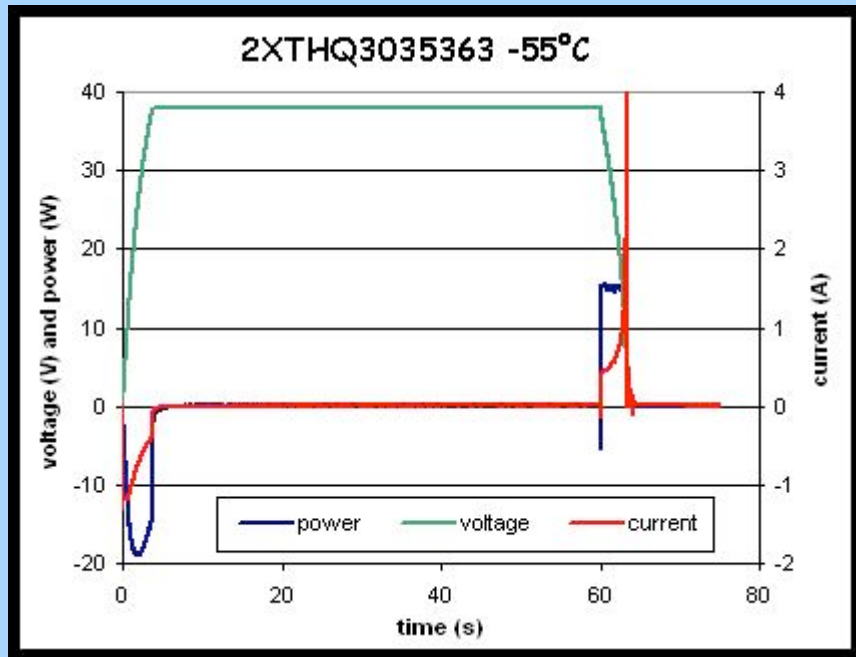

15W Constant Power

Pulse Forming from Low Power Source

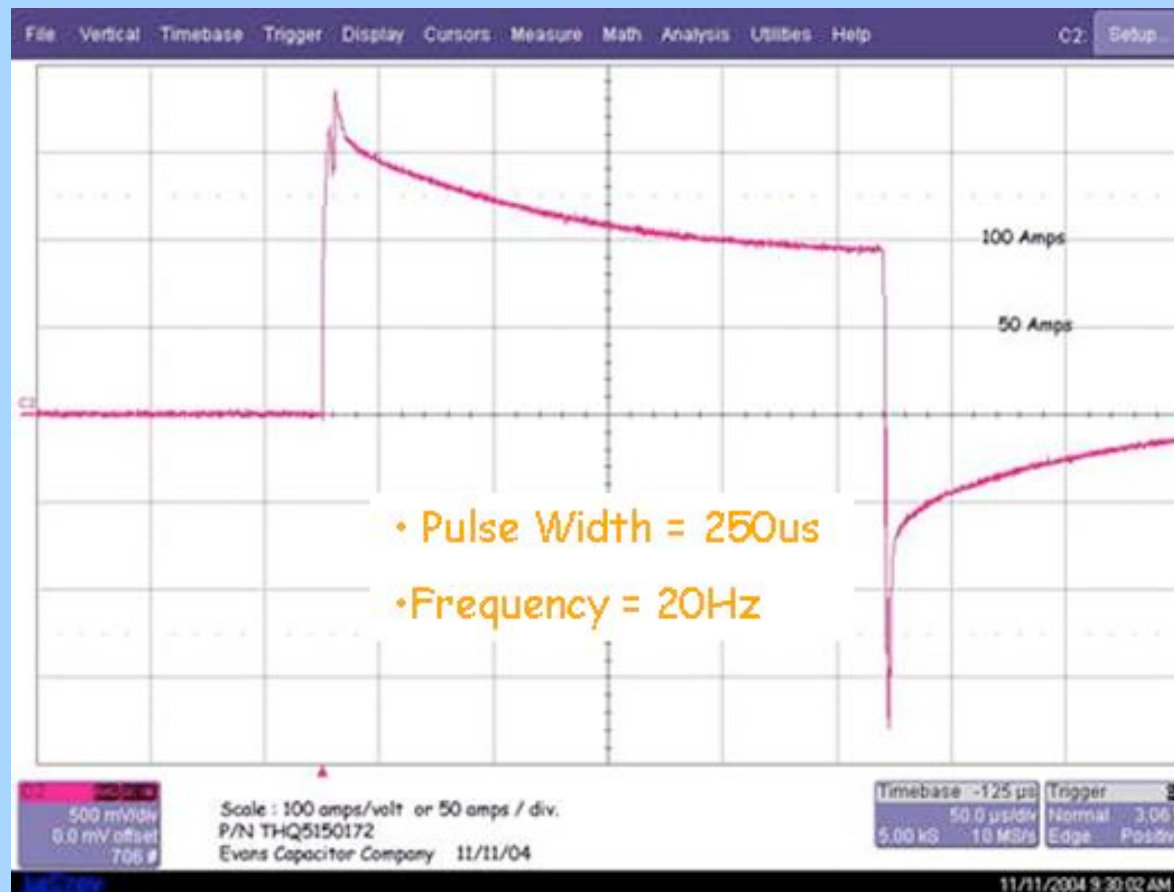

Capacitance and ESR vs. Temperature

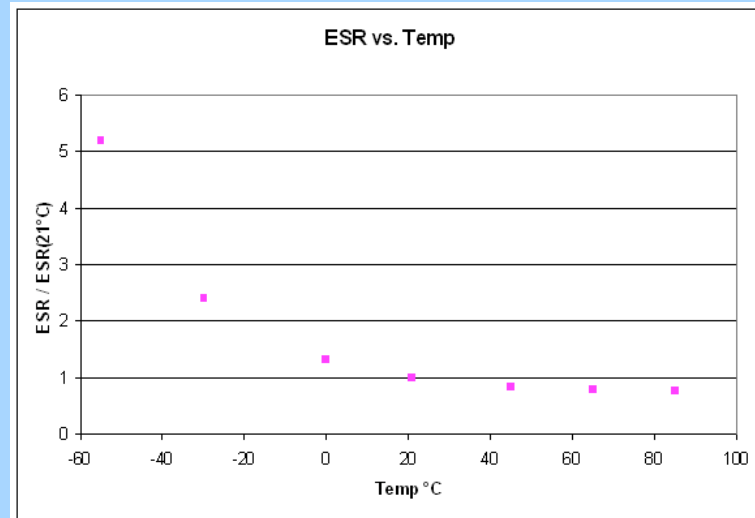
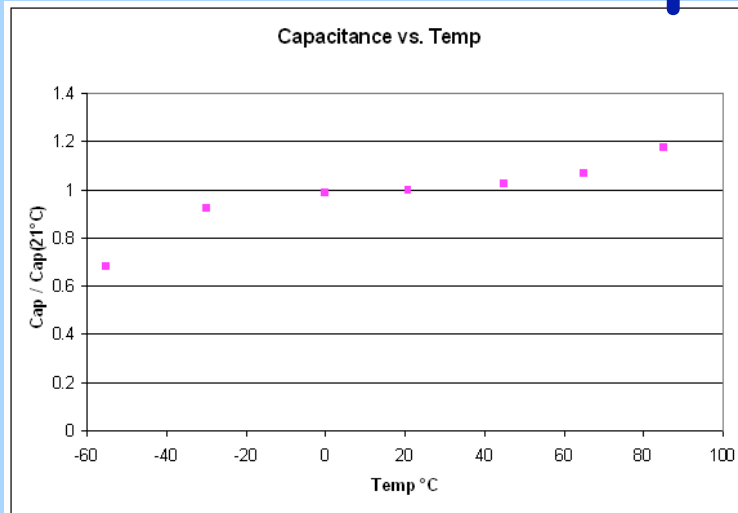

AC Impedance Spectra

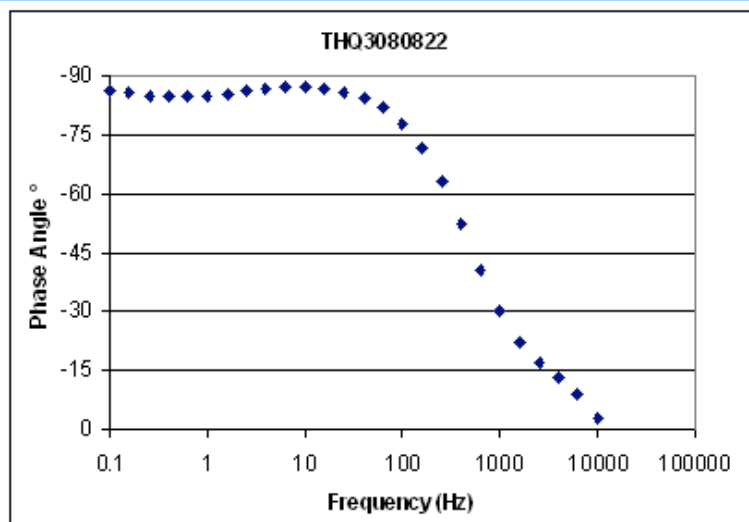
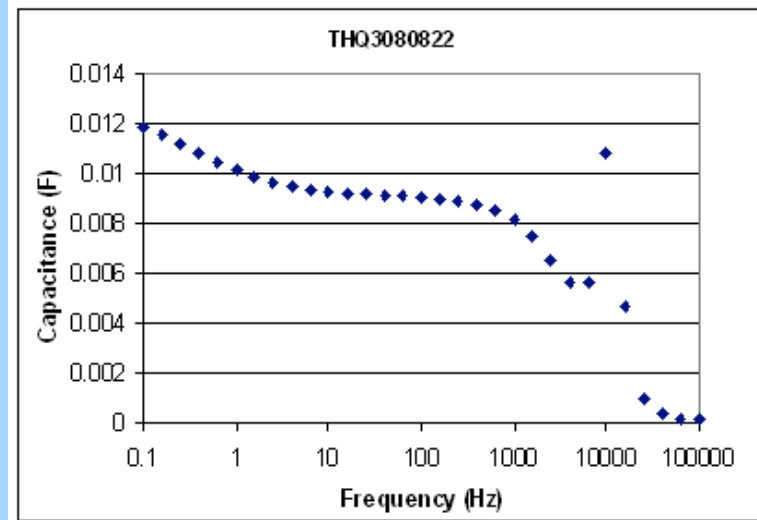
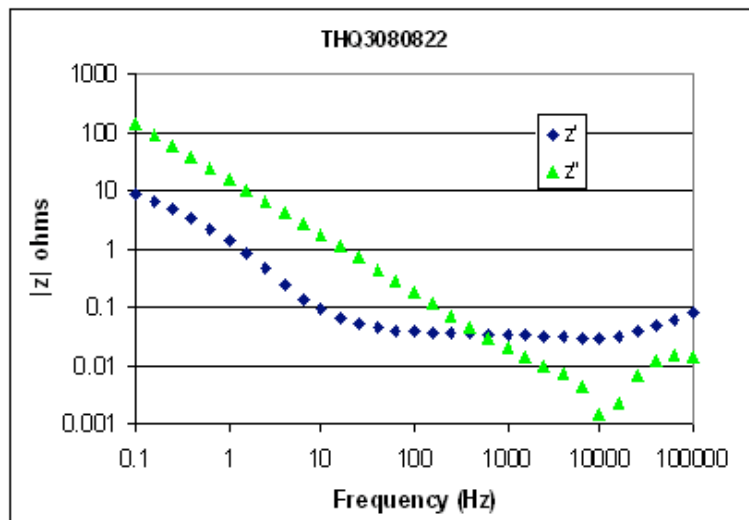

- Capacitance = 8.9mF at 120Hz
- ESR = 0.034ohm at 1kHz
- -45° phase angle at 600Hz
- Leakage Current = 50uA

Life Test Results

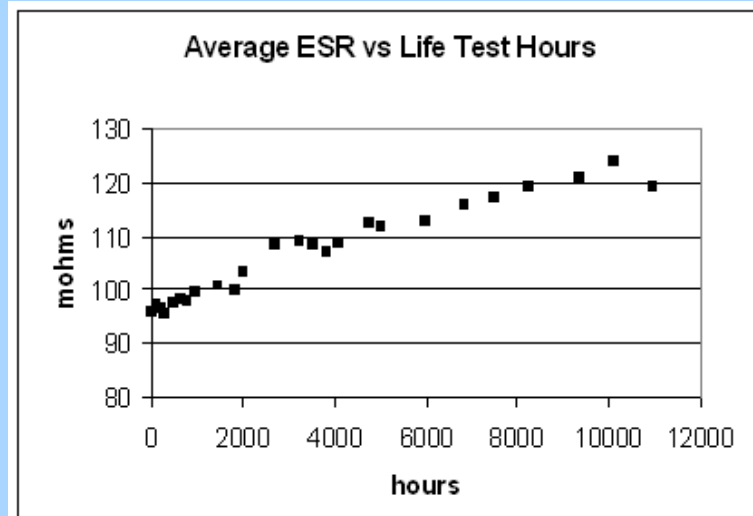
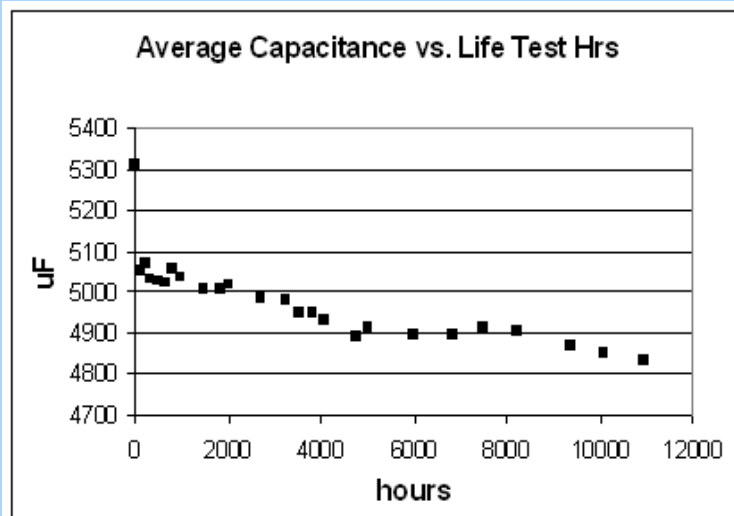

- THQA2016502
- n=10
- 16V @ 85°C

Failure Mechanisms

- dissociation of the electrolyte, proportional to $I_1 \cdot t$
- hydrogen reacts with tantalum negative electrode, eventually embrittling it
- when hydrogen capacity of negative electrode is reached, H_2 gas is liberated, swelling the case
- change in shape and electrolyte loss result in increase in ESR and falling capacitance

Hybrid Capacitor Applications

- Back up power
- Phased array radar antenna
- Laser power supply
- Military radio communications
- Avionics display and instrumentation

Hybrid Capacitor Styles

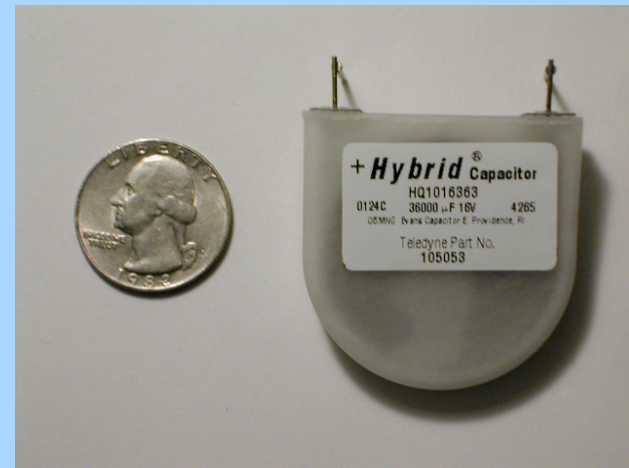

Summary

- High energy-density tantalum Hybrid capacitors are available in voltage ratings from 10 to 150 volts
- Hermetic package for high reliability
- EIS measurements show frequency response similar to electrolytic capacitors
- Energy density 4X higher than tantalum wets, 10X aluminum electrolytics
- Custom designs and ratings available