

PXI Modules

3065 6 GHz PXI RF Combiner Module

AEROFLEX
A passion for performance.



Single slot combination RF switch and power combiner module

- Frequency range up to 6 GHz
- 3 port RF power combiner / splitter
- High speed electronic RF switching
- Internally stored calibration data
- Automatic temperature compensation
- 2 year calibration cycle
- Single slot 3U high

Introduction

The 3065 is a calibrated RF conditioning module featuring integrated high speed RF switches and a high isolation 3 input power combiner / splitter. The 3065 is designed for use with the Aeroflex 3025 6 GHz RF signal generator and 3035 6 GHz RF Digitizer. Together these modules enable the development of compact, high performance low cost modular RF test systems to 6 GHz.

The 3065 can be configured in a variety of ways to enable testing of single port and multi port RF devices across the frequency range 70 MHz to 6 GHz and is supplied in a compact single slot wide 3U high PXI module.

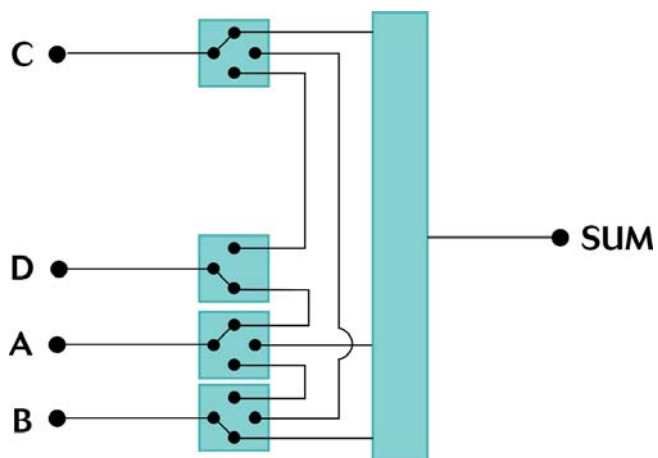
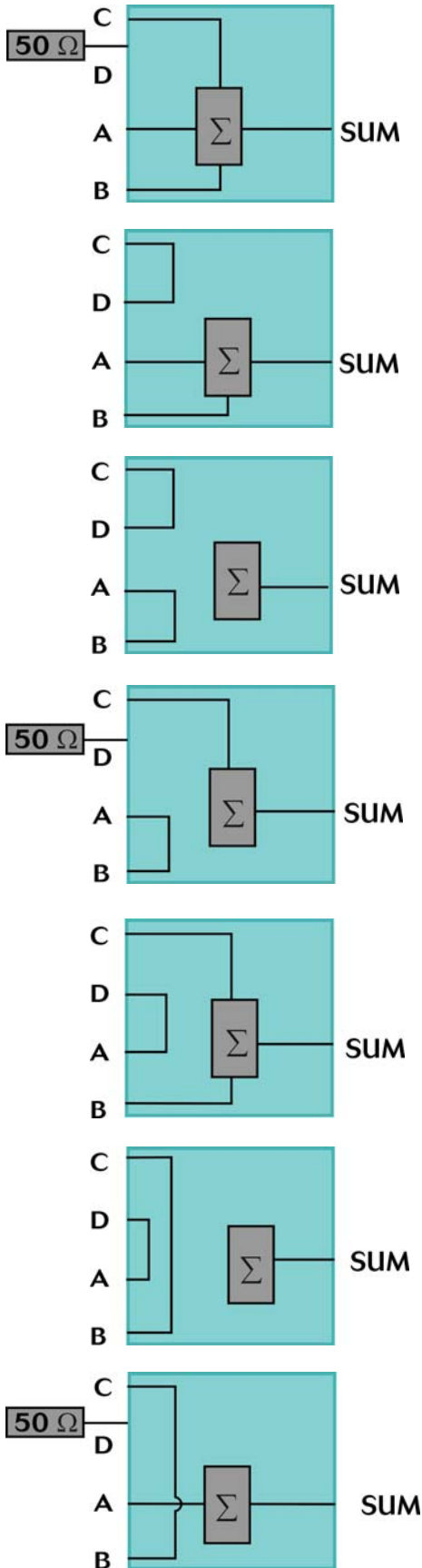

Figure 1. 3065 Combiner block diagram

The following configurations are supported



Fast Switching

High speed electronic RF switching is used to ensure reliable and repeatable performance as well as ensure fast settling times, especially important in high volume manufacturing applications. The example figure below shows the level settles within 0.1 dB of final value in <2 ms.

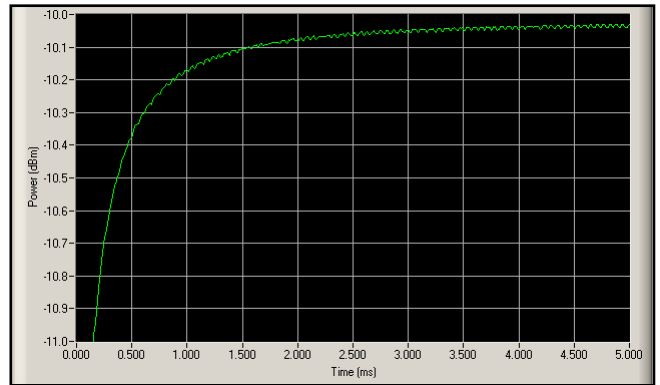

Typical level settling to within 0.1 dB

Calibration

Frequency response calibration data is stored inside the 3065 to help minimize test system uncertainties. Calibration is in the form of frequency response data for each RF signal path. The calibration data is additionally temperature compensated using on board temperature sensing. Calibration data values can be queried over the PCI bus for any given frequency making it possible to simplify system level calibration right up to the plane of the device under test connection port.

Applications

The 3065 is designed for use in a variety of RF test applications. A typical application is to use 3065 with a 3025 RF signal generator and 3035 RF digitizer to test an RF transceiver where the (Σ) port acts as a single port duplex connection point between the two instruments. This configuration relies upon good isolation between the A and C ports which for 3065 is better than 35 dB.

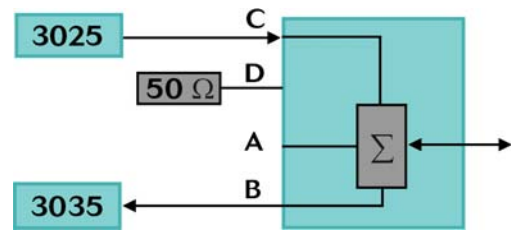

Figure 3 – Transceiver testing

A second RF signal generator connected to port A can be routed to port D providing a second output channel or internally combined at the (Σ) port to enable Rx selectivity and blocking tests to be performed. Equally a second RF digitizer can be connected to port A and routed to port D to provide a second RF input channel. When routed to the (Σ) port the second digitizer can be used to perform simultaneous measurement of the common input. This permits out of band measurement concurrent with in-band measurements on transmitters.

This same configuration is suitable for amplifier or mixer intermod testing in which case two (or three) 3025s can be connected to ports A, B and C providing a single combined RF input to the device under test from the (Σ) port.

Combining two 3065 modules permits a single set of RF signal generation and analysis instruments to switch between multiple devices. Depending how they are configured, testing is either performed sequentially or in parallel thus saving time and money.

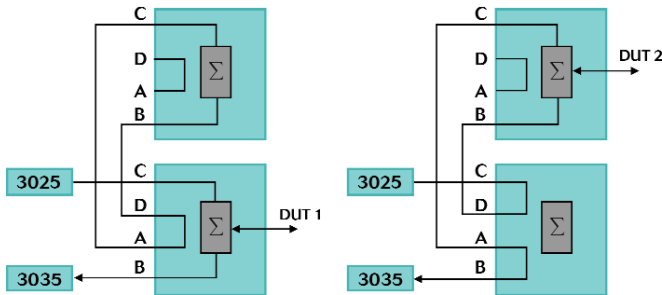

Figure 4 – Dual RF transceiver test with two 3065 modules

For even greater throughput, up to three test devices can be connected in parallel and share a single RF test resource. This is ideal for communication devices using TDMA (Time Division Multiple Access). This not only saves on test time but also on device handling time as well.

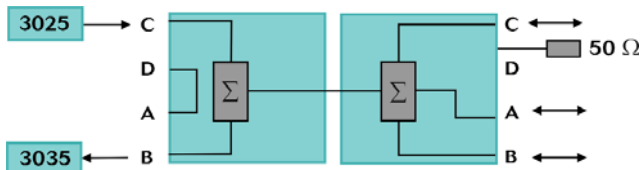

Figure 5 - Testing three devices

Today's modern mobile phones commonly support additional non-cellular functions such as GPS, FM radio and DVB. In which case a second RF source is often required. The second RF source is used concurrently so that cellular mode testing and non cellular mode testing can be performed in parallel. The device under test has independent RF connection points which may now utilize the additional low power D port of the 3065.

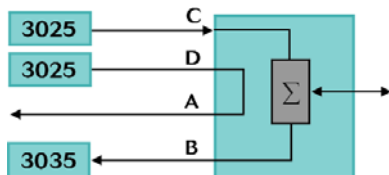

Fig 6 - Simplex and duplex connection

Frequency Response

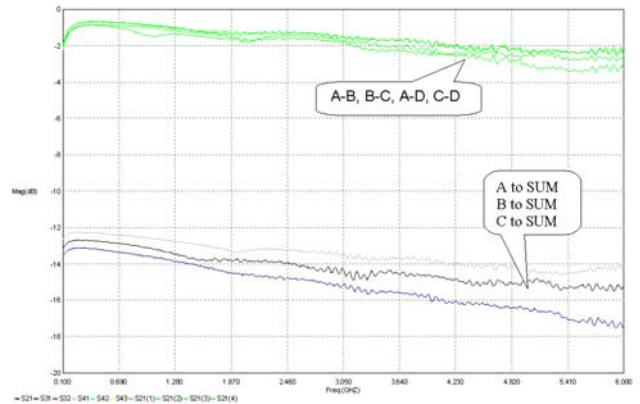

Fig 7 - Frequency response for ABC to SUM (Σ), A-B, B-C, A-D, C-D

Return Loss

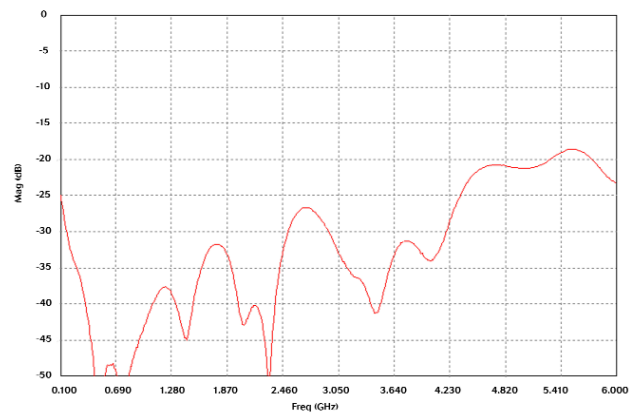
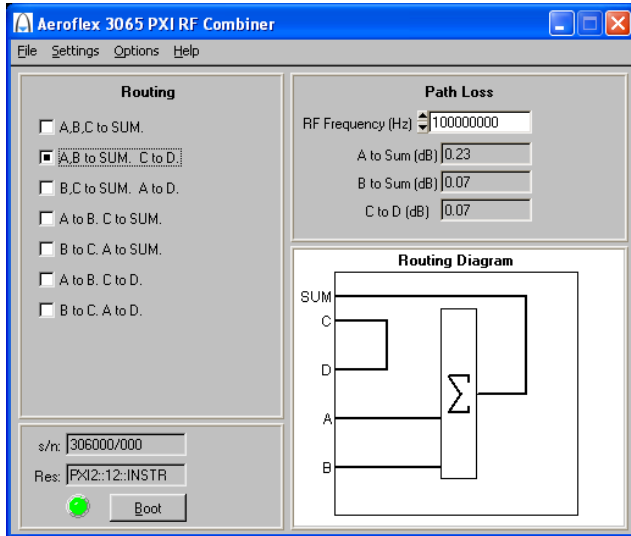

Fig 8 - Return loss at SUM (Σ) port

Software

The 3060 is supplied with a VXIppn Driver and soft front panel.



3065 soft front panel

Customer Support

Users can elect to purchase PXI modules with optional warranty extensions.

Standard Extended Warranty provides either 36 months or 60 months warranty period plus the benefits of guaranteed product repair times in the event of failure.

Standard Extended Warranty can also be provided inclusive of scheduled calibration.

On request Aeroflex can provide customized Premium Warranty support designed around your specific needs.

SPECIFICATION

Frequency Range

All ports: 250 MHz to 6 GHz, useable to 70 MHz

Insertion Loss

Port A, B, C Switched to Σ

Port C to Σ

250 MHz to 6 GHz <16 dB

Port A / B to Σ

250 MHz to 2.7 GHz <15.5 dB

2.7 GHz to 6 GHz <17.5 dB

Ports Switched A-B or B-C

(unswitched port routed to Σ)

250 MHz to 2.7 GHz <3 dB

2.7 GHz to 6 GHz <5 dB

Ports C-D, A-D

250 MHz to 2.7 GHz <3 dB

2.7 GHz to 6 GHz <5 dB

Calibration Uncertainty (23°C +/-5°C)

Below 2.7 GHz 0.2 dB

2.7 to 5 GHz 0.3 dB

5 GHz to 6 GHz 0.4 dB

Temperature Stability

± 0.006 dB/°C (A,B,C to SUM port)

± 0.002 dB/°C (all other paths)

Repeatability

Better than ± 0.05 dB after warm up following a return from a change of mode valid for at least 2 hours and excluding temperature influence.

Frequency Response

250 MHz to 2.7 GHz <2 dB

2.7 GHz to 6 GHz <4.5 dB

Return Loss

(unused ports terminated into 50 ohms)

Port Σ

250 MHz to 2.7 GHz >20 dB

2.7 GHz to 5 GHz >18 dB

5 GHz to 6 GHz >16 dB

Port A - Σ

>11 dB, typically 14 dB

Ports B, C and D - Σ / A-B, B-C, C-D, A-D

250 MHz to 2.7 GHz >14 dB, typically 17 dB

2.7 GHz to 6 GHz >11 dB, typically 14 dB

Isolation Between Ports

(unused ports terminated into 50 ohms)

B-C >35 dB below 2 GHz otherwise >32 dB

All other ports >35 dB

Max Power (Σ)

+27 dBm, 3 VDC continuous

+30 dBm MS 1:8 where M <0.5 ms

Max Power (A, B, C, D)

+24 dBm

GENERAL

Standard Warranty

24 months

Calibration Interval

Recommended 2 year

Power Consumption (typical)

+3.3 V <50 mA (transiently rising to 250 mA during power up)

+5 V <50 mA

+12 V <50 mA

-12 V <50 mA

Electromagnetic Compatibility

EN 61326-1:1997, Emissions Class A, Immunity Table 1 – Performance Criteria B

Safety

EN 61010-1:2001 Safety requirements for electrical equipment for measurement, control and laboratory use-Part 1, General requirements

Driver Software

VXIpnp compliant software driver

INTERFACES

All connectors are SMA

DIMENSIONS AND WEIGHT

Dimensions

Single width 3U PXI module

Weight

330 g (0.7 lbs)

RATED RANGE OF USE

Operating Temperature

0 to 50°C, meets IEC-60068-2-1 and 60068-2-2

Operating Humidity

10 to 90% non-condensing, meets IEC-60068-2-56

CONDITIONS OF STORAGE AND TRANSPORT

Storage Temperature

-20 to +70°C, meets IEC-60068-2-1 and 60068-2-2

Storage Humidity

5 to 93% non-condensing, meets IEC-60068-2-56

Shock

30 g peak, half sine, 9 ms pulse. Tested in accordance with IEC-60068-2-27

Random vibration 5 Hz to 500 Hz, 2.46 g rms non-operating. Tested in accordance with IEC-60068-2-64

COMPLIANCE

PXI Specification, Revision 2.1

VXIpnp Specifications (VPP-2, VPP-3.x, VPP-4.x and VPP-7)

VERSIONS, OPTIONS AND ACCESSORIES

When ordering please quote the full ordering number information.

Ordering Numbers

3065

Versions

PXI RF combiner

Supplied with

CD ROM containing VXIpnp driver, soft front panel and user documentation

SMA 50 ohm termination

SMA link cable x 3

Service Options

W3060/103 Standard Extended Warranty 36 months

W3060/103C Standard Extended Warranty 36 months with scheduled calibration

W3060/105 Standard Extended Warranty 60 months

W3060/105C Standard Extended Warranty 60 months with scheduled calibration

Optional Accessories

43139/590 SMA link cable

82532 SMA 50 ohm termination

46885/224 SMA connector saver

82536 PXI Assy, 8 slot chassis with 2.2 GHz P4 embedded controller (Windows XP)

82544 PXI Assy, 8 slot chassis with MXI-4 PCI-PXI interface

82538 PXI Assy, 18 slot chassis with 2.2 GHz P4 embedded controller (Windows XP)

82545 PXI Assy, 18 slot chassis with MXI-4 PCI-PXI interface

46662/767 PXI hard carry case (for use with 82536, 82544)

For the very latest specifications visit www.aeroflex.com

CHINA Beijing

Tel: [+86] (10) 6539 1166
Fax: [+86] (10) 6539 1778

CHINA Shanghai

Tel: [+86] (21) 5109 5128
Fax: [+86] (21) 5150 6112

FINLAND

Tel: [+358] (9) 2709 5541
Fax: [+358] (9) 804 2441

FRANCE

Tel: [+33] 1 60 79 96 00
Fax: [+33] 1 60 77 69 22

GERMANY

Tel: [+49] 8131 2926-0
Fax: [+49] 8131 2926-130

HONG KONG

Tel: [+852] 2832 7988
Fax: [+852] 2834 5364

INDIA

Tel: [+91] 80 5115 4501
Fax: [+91] 80 5115 4502

KOREA

Tel: [+82] (2) 3424 2719
Fax: [+82] (2) 3424 8620

SCANDINAVIA

Tel: [+45] 9614 0045
Fax: [+45] 9614 0047

SPAIN

Tel: [+34] (91) 640 11 34
Fax: [+34] (91) 640 06 40

UK Burnham

Tel: [+44] (0) 1628 604455
Fax: [+44] (0) 1628 662017

UK Cambridge

Tel: [+44] (0) 1763 262277
Fax: [+44] (0) 1763 285353

UK Stevenage

Tel: [+44] (0) 1438 742200
Fax: [+44] (0) 1438 727601
Freephone: 0800 282388

USA

Tel: [+1] (316) 522 4981
Fax: [+1] (316) 522 1360
Toll Free: 800 835 2352

As we are always seeking to improve our products, the information in this document gives only a general indication of the product capacity, performance and suitability, none of which shall form part of any contract. We reserve the right to make design changes without notice. All trademarks are acknowledged. Parent company Aeroflex, Inc. ©Aeroflex 2006.

www.aeroflex.com
info-test@eroflex.com



Our passion for performance is defined by three attributes represented by these three icons: solution-minded, performance-driven and customer-focused.