

## The Hidden Decisions Behind Covert Surveillance

The challenge of increased performance requirements with reduced power, size and weight

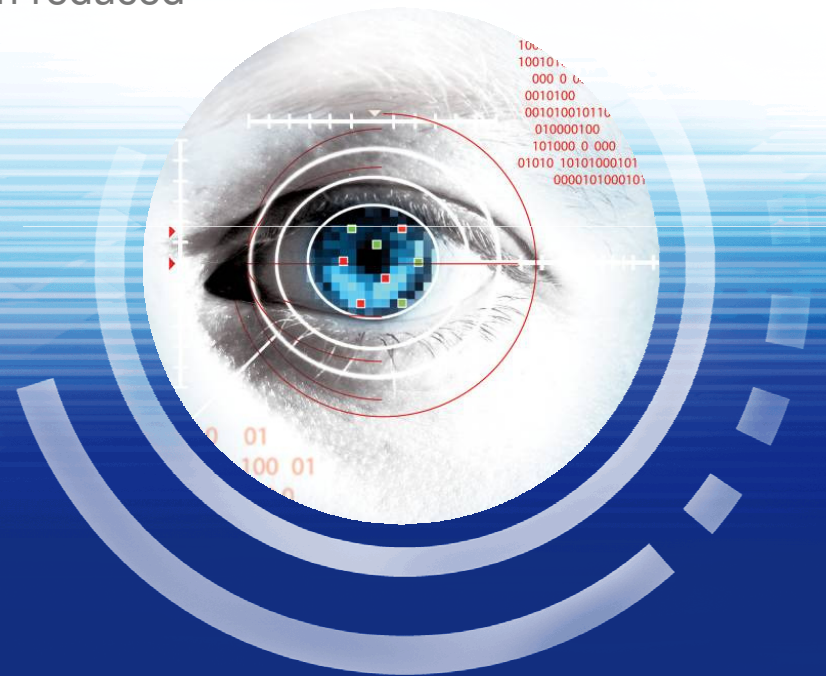

European Microwave 2011 – Defence & Security Forum

Steve Williamson – Principal Engineer

## The Hidden Decisions Behind Covert Surveillance - Agenda

### Agenda:

- 1 Introduction**
- 2 The battlefield today**
- 3 The hidden decisions**
- 4 prism200 – Case study 1**
- 5 Sidewinder™ – Case study 2**
- 6 Summary**

## The Hidden Decisions Behind Covert Surveillance - Introduction

**Cambridge Consultants is one of Europe's leading design and development houses, established for 50 years**

We employ around 300 engineers, designers, scientists and support staff providing

- Independent assessment of technologies and solutions
- Development of leading edge hardware and software demonstration systems
- Transition of proof of concept systems to deployable products



50  
YEARS  
OF INNOVATION



THE QUEEN'S AWARDS  
FOR ENTERPRISE:  
INNOVATION  
2011



THE QUEEN'S AWARDS  
FOR ENTERPRISE:  
INTERNATIONAL TRADE  
2009

## The Hidden Decisions Behind Covert Surveillance - The battlefield today

**Today's battlefield is not limited by borders. Locations range from local and domestic to international, using land, sea, air and space.**

Requirements for operational use have never been more demanding, with performance only limited by the 'laws of physics'.

- Range of users across all forces
  - Police
  - Army, Navy, Air Force
  - SF, SWAT
- Technology requirements almost identical
  - Environment usually the key differentiator
- Adversaries have become increasingly technically capable
  - Surveillance aware



## The Hidden Decisions Behind Covert Surveillance - Agenda

### Agenda:

- 1 Introduction
- 2 The battlefield today
- 3 The hidden decisions
- 4 prism200 – Case study 1
- 5 Sidewinder™ – Case study 2
- 6 Summary

## The Hidden Decisions Behind Covert Surveillance - The hidden decisions

### Delivering low power, low weight systems requires a combination of approaches embedded within the overall development programme

Develop the key requirements from a user perspectives by examining operational scenarios

#### Identify

- Power, size, weight, performance and cost

#### Implementation trade-offs

- Off-the-shelf versus bespoke
- Radical versus incremental innovation

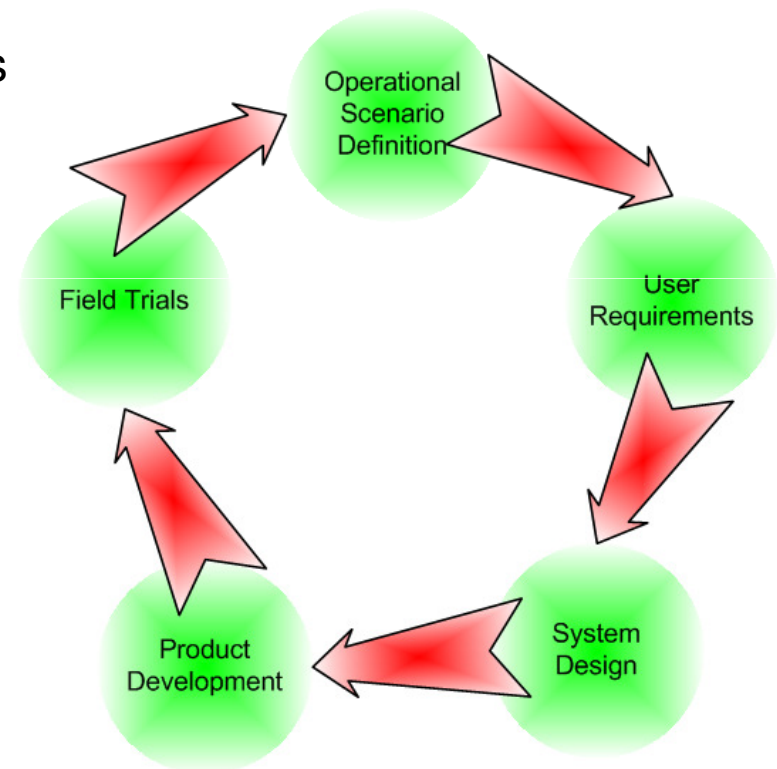

## The Hidden Decisions Behind Covert Surveillance - Scenario Definitions

Identifying the usage scenarios for any equipment is important for a successful development. Engaging with the end user ensures ‘buy in’ to the final product.

- Develop the key requirements from a user perspectives by examining operational scenarios and compare them to **ALL** perceived requirements.

Scenario	Operational Modes					
	Through Wall Tracking	GPS Location	WiFi Link	GSM Detection	Blue/Red Force Identification	Night Display
1	Essential	Essential	Essential	Essential	Desirable	Unnecessary
2	Essential	Desirable	Unnecessary	Desirable	Desirable	Essential
3	Essential	Desirable	Desirable	Essential	Desirable	Unnecessary
4	Unnecessary	Desirable	Desirable	Essential	Unnecessary	Unnecessary

- This comparison should lead to:
  - Reduced and focused set of requirements
  - Simplification/rationalisation of the design
  - Identification of challenging design requirements
    - IP ratings, battery life, operating temperature

## The Hidden Decisions Behind Covert Surveillance - Power

**Power is often the driver in portable battlefield systems, directly affecting size and weight. Batteries are evolving rapidly due to portable consumer devices.**

- Main technologies
  - Lead-Acid : Traditionally used for bulk storage
  - NiMH : Now at its development limit
  - NiCd : Phasing out due to toxicity
  - Li-Ion : Highest energy density
- Portable/consumer electronic equipment driving:
  - Increased capacity
  - Shape and size
  - Vehicle technology driving charging rate
- Standardisation a major issue
  - Common products
  - ‘AA’ still very popular
    - Easy to obtain ‘locally’

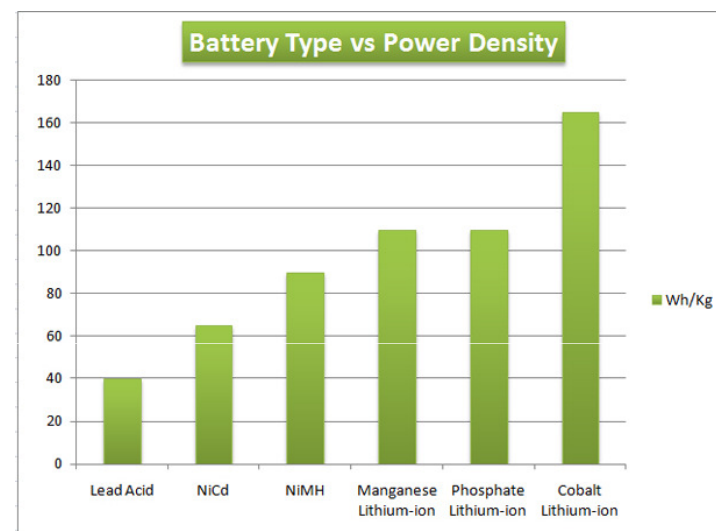

## The Hidden Decisions Behind Covert Surveillance - Power

### Solar power is becoming more accessible as a charging source for battery powered equipment.

Use of solar power for direct source or charging batteries is becoming common place

- Becoming more robust and flexible
  - Amorphous silicon
- \$1 per Watt manufacturing cost
  - Can be coloured for camouflage

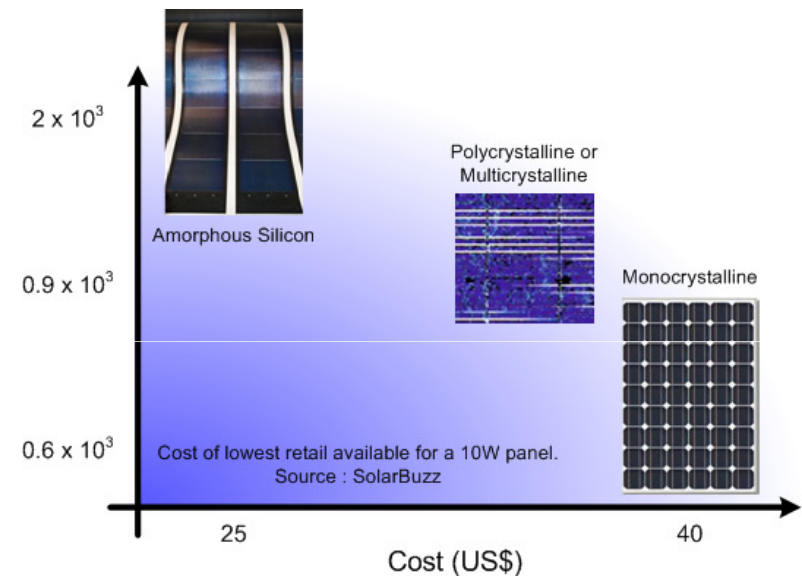

### 'Solar Soldier' Project

- EPARC and MoD funded research with DSTL and UK universities
  - 50 percent lighter power source with solar and a thermoelectric-powered system
  - Due to complete Q4 2011



## The Hidden Decisions Behind Covert Surveillance - Size and Weight

**Size and weight are only limited by the physical volumes within the equipment.  
Material choices can help improve product ruggedness and weight, despite size.**

- Again, usage scenarios drive requirements
  - Weight limit
    - 1kg is normal one hand weight limit
    - End user's opinion can be very polarised
    - Use of metals such as magnesium
  - Size
    - Palm sized ► Is it a key requirement?
  - Environmental
    - UV Resistant ► Limits use of some plastics
    - Sunlight exposure implies display issues
    - Minimise case parts to reduce number of seals
  - Drop test limits
    - Rigidity/bulk not always the solution
    - Shock mounting

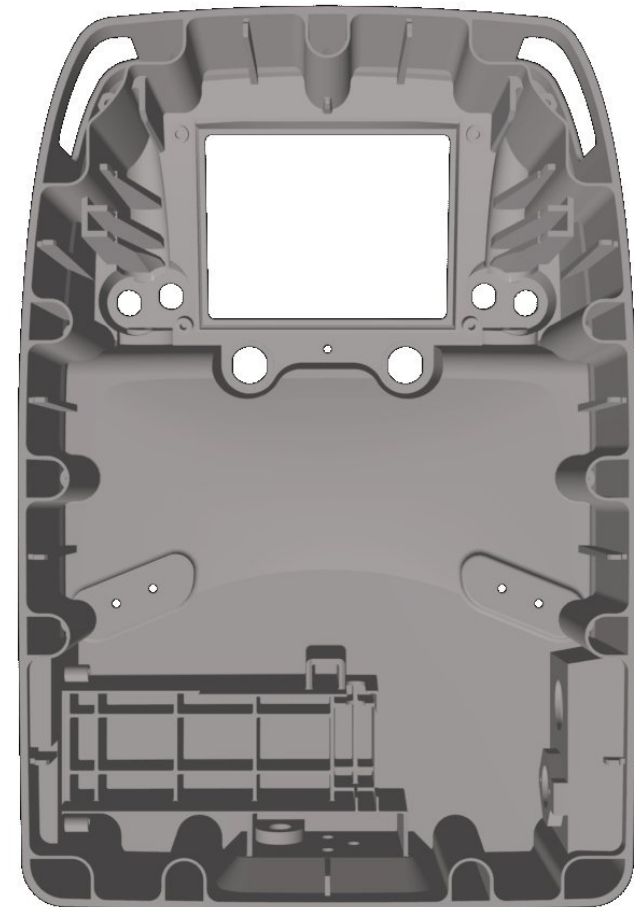

## The Hidden Decisions Behind Covert Surveillance - Size and Weight

**Simplified interfaces to operate equipment reduce training times and reduce the need for skilled operators, offering manufacturers potential for volume supply.**

- Cont..

- Human factors
  - Gloved operation?
  - Removable batteries ► more seals
- MMI
  - More buttons ► more seals
  - Daylight and/or night viewable
  - Required beyond on/off/standby?



## The Hidden Decisions Behind Covert Surveillance - Agenda

### Agenda:

- 1 Introduction
- 2 The battlefield today
- 3 The hidden decisions
- 4 **prism200 – Case study 1**
- 5 Sidewinder™ – Case study 2
- 6 Summary

## The Hidden Decisions Behind Covert Surveillance - prism200

### A key challenge at the start of the programme was that users requirements were ill-defined

Capability gap was easy to describe along with customer desire to meet it

Requirements were less easy to define

- Customer wish lists with no defined means of measurement

We took a step back...

*How, when and where will it be used?*

*What is a wall?*

*What information is it desirable to provide?*

*How is the product to be packaged?*

*What is a room?*

*What information is it essential to provide?*

*How is it to be sold and supported?*

**Understanding the user requirements and their implications defines the system constraints and what is required to meet them, and hence the power required**

## The Hidden Decisions Behind Covert Surveillance - prism200

We evolved the design through a number of prototypes to determine performance, feasibility and define product features from requirements



***prism100***

Initial Development System



***prism200*** Prototype

Handheld Proof of Concept



***prism200***

Full Production Version

## The Hidden Decisions Behind Covert Surveillance - prism200

**The system design enables a link to be created from the user requirements to key parameters of performance, size, weight and power consumption**

Overall partitioning provides the basis for defining design models

- Performance
- Size
- Weight
- Power Consumption

These are then used to perform design trade-offs

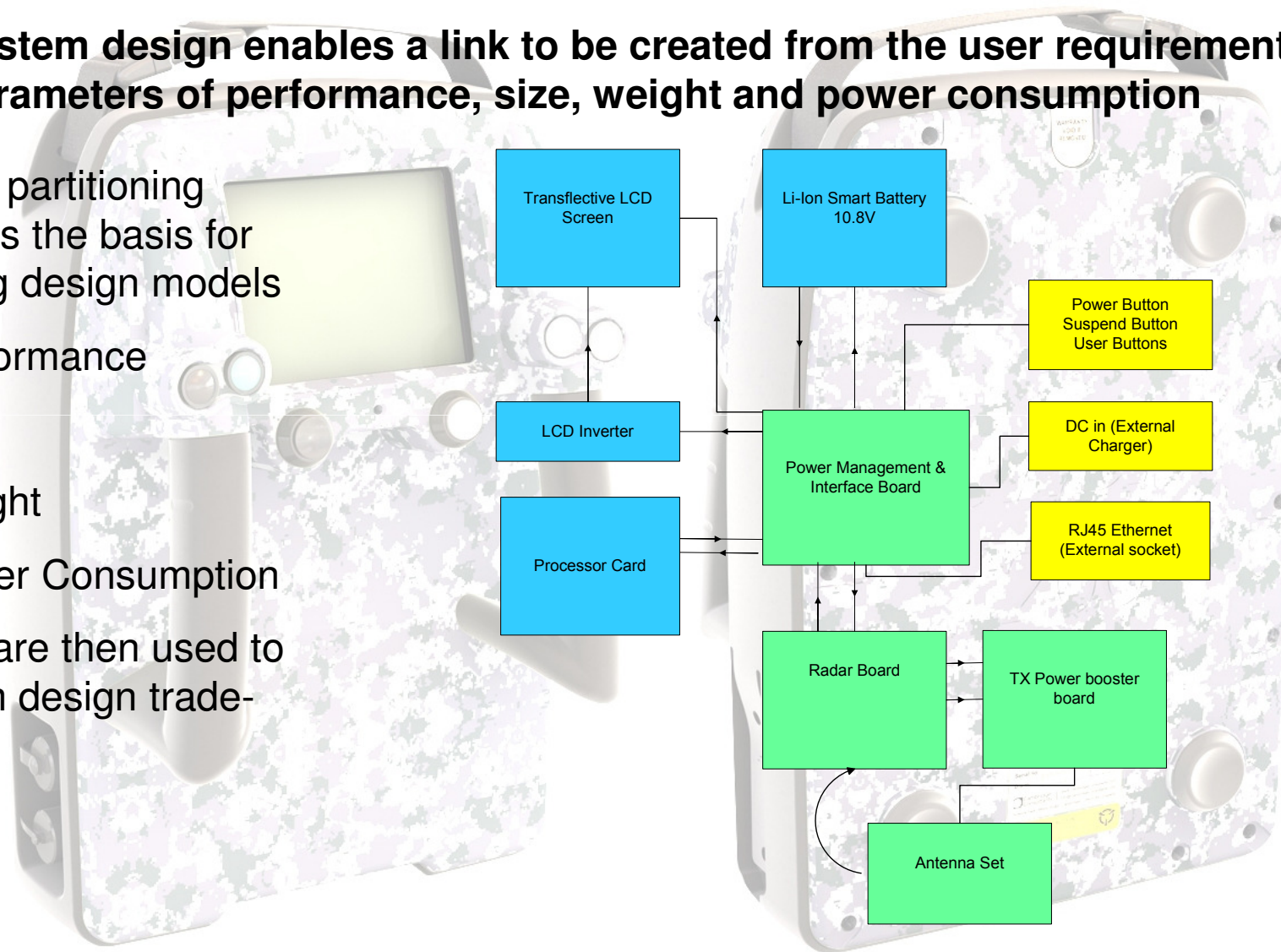

## The Hidden Decisions Behind Covert Surveillance - prism200

**The system design enables a link to be created from the user requirements to key parameters of performance, size, weight and power consumption**

Design trade offs

- Backlight usage vs power consumption
- Radar transmit power versus performance

System performance is ultimately limited by processing performance not radar performance

Enclosure to meet the environmental design requirements dominates the weight budget

- Single handed operation
- Limited by the antenna surface area required to resolve objects

Power Consumption Split

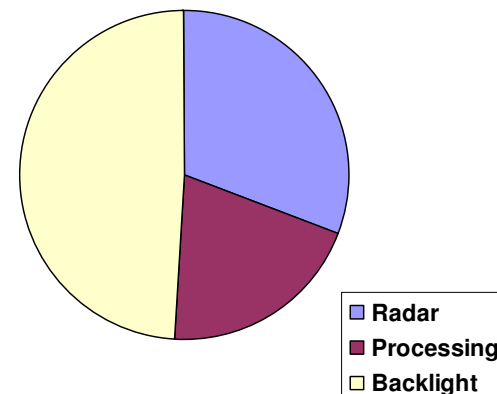

Weight Split

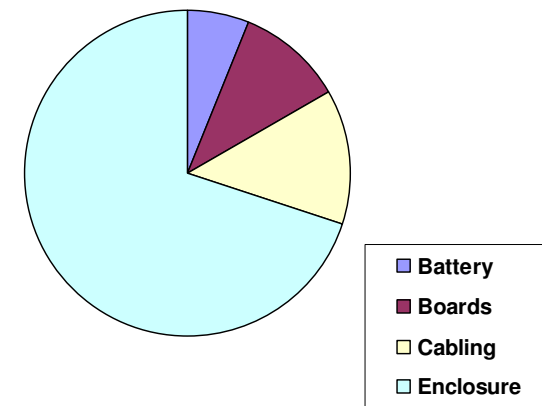

## The Hidden Decisions Behind Covert Surveillance - prism200

### Implementation uses a combination of COTS components and bespoke components to deliver the required performance

COTS components used for processor, battery and display

- Already optimised for low power / long deployment operation

Radar board provides a transmitter, multiple receivers and target processor on a single PCB with a power consumption of under 3.5W when running continuously

- Target list exported to the main processor for higher level tracking and display

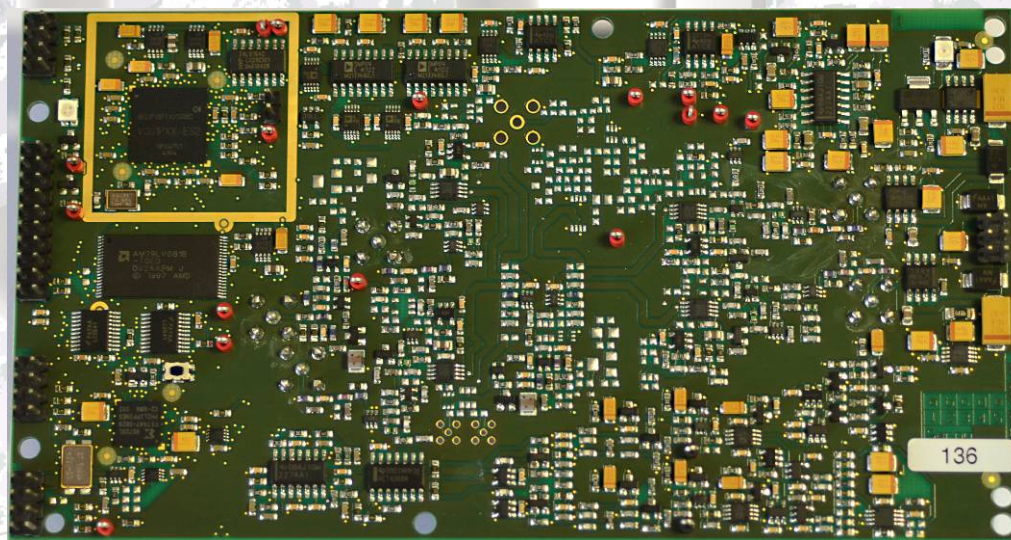

Size: 170mm x 80mm

## The Hidden Decisions Behind Covert Surveillance - Agenda

### Agenda:

- 1 Introduction
- 2 The battlefield today
- 3 The hidden decisions
- 4 prism200 – Case study 1
- 5 Sidewinder™ – Case study 2
- 6 Summary

## The Hidden Decisions Behind Covert Surveillance - Sidewinder

**A Small-cell Base Station was identified as being required by end users. It had to be portable, low-power and covertly deployable.**

- Selection of low-power components key to battery operation
  - Power hungry application
  - Picochip PC312 Femtocell Baseband SoC provided DSP performance + low power

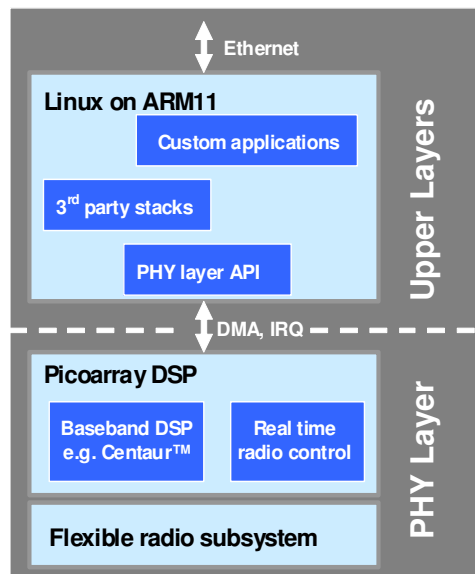

Software Environment

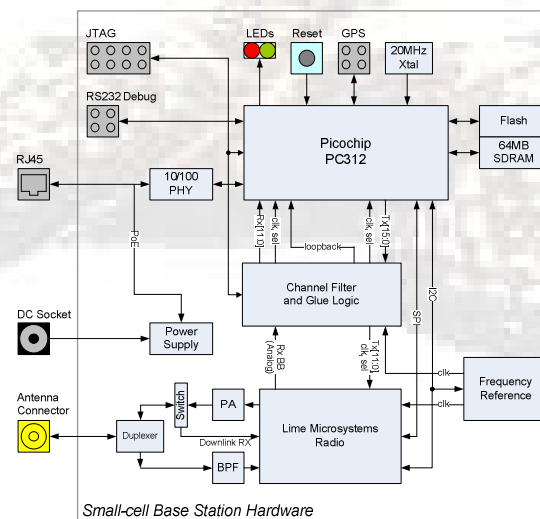

Hardware Architecture



## The Hidden Decisions Behind Covert Surveillance - Sidewinder

**Software and hardware system architectures were defined in parallel to ensure functional requirements were met.**

- A feature set was defined in conjunction with potential end-users
  - High-end generic SDR platform
  - Operate from 375MHz to 4GHz
  - Channel BW up to 28MHz
  - Configurable as a minimum for:
    - 2G GSM ► GSM / GPRS / EDGE
    - 3G WCDMA
- Functions to include IMSI grabbing and occupancy monitoring
- Other requirements
  - Low power and portable ► battery powered
  - Variety of timing references
    - IEEE, GPS, network listen

Feature	Specification
<b>Radio channels</b>	Configurable for one of: <ul style="list-style-type: none"> <li>• GSM 850, 900, 1800 or 1900</li> <li>• 3G Band-I [2.1GHz]</li> </ul>
<b>Dimensions</b>	92mm x 80mm
<b>Power</b>	6W (max)
<b>TX Power</b>	+5dBm
<b>RX Sens.</b>	-104dBm (for GSM)
<b>Ant. Port</b>	Single SMA Connector
<b>GPS</b>	Interface to external GPS for PPS
<b>Connectors</b>	Ethernet 100BT Debug – JTAG, UART
<b>Electronic Bill of Materials</b>	< US\$ 200 (1000 off)

## The Hidden Decisions Behind Covert Surveillance - Agenda

### Agenda:

- 1 Introduction
- 2 The battlefield today
- 3 The hidden decisions
- 4 prism200 – Case study 1
- 5 Sidewinder™ – Case study 2
- 6 Summary

## The Hidden Decisions Behind Covert Surveillance - Summary

**Reducing the burden requires an end-user focussed design approach which also addresses low power and low weight design from conception.**

- Define the usage scenarios early in development
- Contrast what is *essential* from what is *desirable*
  - Power, size and weight can be radically altered at this point
- End-user feedback and experience can validate product concept features against requirements
- Invest time in system partitioning and development of performance models to enable design decisions to be taken in the context of user requirements
- Consider COTS components versus bespoke development
  - Volume pricing may improve competitive edge
  - Shortens development times
- Identify where innovation can provide significant benefits
  - Hardware rarely outweighs the value of algorithms and signal processing

## Contact details:

### Cambridge Consultants Ltd

Science Park, Milton Road  
Cambridge, CB4 0DW  
England

Tel: +44(0)1223 420024  
Fax: +44(0)1223 423373

Registered No. 1036298 England

[info@CambridgeConsultants.com](mailto:info@CambridgeConsultants.com)  
[www.CambridgeConsultants.com](http://www.CambridgeConsultants.com)

### Cambridge Consultants Inc

101 Main Street  
Cambridge MA 02142  
USA

Tel: +1 617 532 4700  
Fax: +1 617 532 4747

Cambridge Consultants is part of the Altran group, the  
European leader in Innovation Consulting. [www.Altran.com](http://www.Altran.com)

**Commercially Confidential** This Presentation contains ideas and information which are proprietary to Cambridge Consultants Limited and/or Cambridge Consultants Inc: it is given to you in confidence. You are authorised to open and view any electronic copy we send you of this document within your organisation and to print a single copy. Otherwise the material may not in whole or in part be copied, stored electronically or communicated to third parties without the prior written agreement of Cambridge Consultants Limited and/or Cambridge Consultants Inc.

© 2011 Cambridge Consultants Ltd, Cambridge Consultants Inc. All rights reserved.

