

 **Mini-Circuits®**

Smart Portable Test Equipment

Your Instrumentation Partner

March 13, 2012

MWJ Webinar

Introduction





Mini-Circuits has developed a family of Portable Test Equipment (PTE) that can provide quick and accurate test results without big investment in complex test equipments. All modules include built-in user-friendly GUI for users without programming experience. Additionally, our modules are fully compatible with 32/64-bit Windows® or Linux® operating systems, as well as LabVIEW®, C++, C#, Visual Basic®, and .NET software. This allows integration of our modules into existing set up very easy to perform and system expansion is also achievable at very low cost.

With 40 years of experience in high volume RF testing environment, Mini-Circuits can also supply complete test solutions by integrating the PTE modules together with our application specific software that can significantly reduce test time and increase production throughput.

Portable Test Equipment Overview



Category	Family	Product	Key Benefits
Signal Source	Synthesized Signal Generators <i>(Wideband & Optimized band)</i>		<ul style="list-style-type: none"> ➤ Freq: 250 - 4000 MHz P_{out}: -50 to +20 dBm Step size: 5kHz – 10 MHz Very low harmonics
			<ul style="list-style-type: none"> Freq: 900 – 960 MHz <i>(many other models available)</i> P_{out}: -10 to +15 dBm No external power supply
Signal Processing	Switch Matrices		<ul style="list-style-type: none"> Freq: DC – 18 GHz Isolation between ports: 85dB 100 million operating cycles
Signal Monitoring	Power Sensors		<ul style="list-style-type: none"> Freq: 1 – 8000 MHz Dynamic Range: -30 to +20dBm 30 msec response time
	Frequency Counter		<ul style="list-style-type: none"> Freq: 1 – 6000 MHz Dynamic Range: -28 to +13dBm 100 msec sampling time

Companion PTE Products



USB-I/O Control Box

is a general purpose USB controlled I/O box which provides multiple digital I/O lines and form C relays with dry contact outputs



USB Digital Step Attenuator

is a general purpose 50Ω RF digital step attenuator controlled via either USB or RS232 ports. Attenuation range in 0.5 dB steps from 40 to 90 dB available. Frequency of operation is up to 4 GHz.



RS232 & USB to SPI Converter

is a compact USB to SPI and RS232 to SPI converter operating at a baud rate of 9600 with an even parity bit and 8 data bits per word. The converter uses standard TTL levels for the SPI signals



Wideband Synthesized Signal Generators

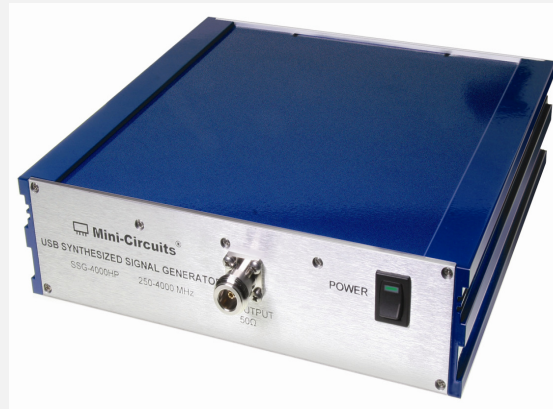

+24V

Very Low Harmonics model

SSG-4000LH

High Output Power model

SSG-4000HP

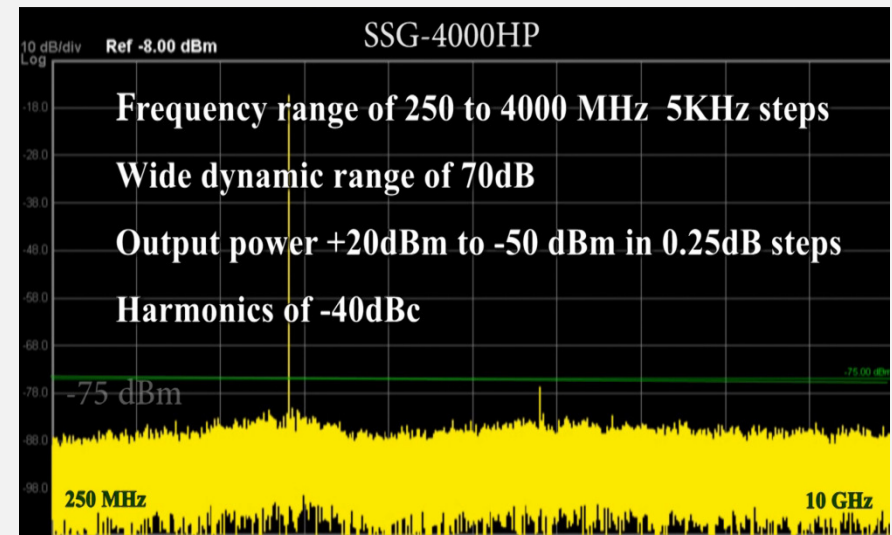
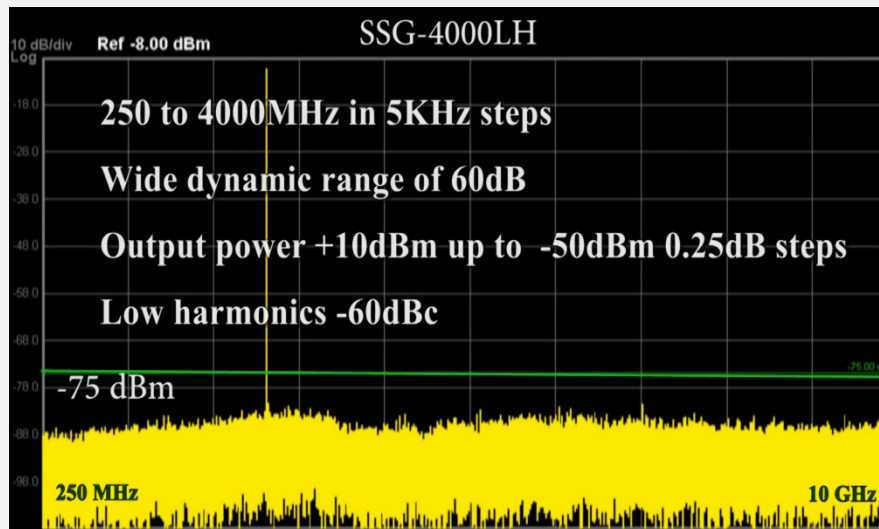

SSG-4000HP Main Control Screen



The screenshot shows the 'Mini-Circuits USB Synthesized Signal Generator' software window. The interface includes several control panels and status indicators:

- Mode Selection:** 'Main' (selected), 'Sweep Mode', 'Hop Mode', and 'Multi Gen. Control' buttons.
- Frequency Control:** A digital display shows '500.000' MHz. The range is '250 MHz' to '4000 MHz'. Radio buttons for 'MHz' (selected) and 'GHz' are present. An 'Incr Set' button is located to the right.
- Power Control:** A digital display shows '0.00' dBm. The range is '-50.00 dBm' to '+20.00 dBm'. Radio buttons for 'dBm' (selected), 'mW', and 'uW' are present. An 'Incr Set' button is located to the right.
- RF Status:** A green 'RF ON' button is highlighted.
- Spur/Noise Settings:** Radio buttons for 'Lowest Spurs' and 'Lowest Noise' (selected).
- Status:** A red 'Warming Up!' message is displayed.
- Device Information:** 'Generator Model: SSG-4000HP' and 'Serial Number: 11108090008'.
- Display Options:** 'Always on top' and 'Compact View' checkboxes.
- Address:** 'Address (1 to 255): 255' with a 'Set' button.

SSG-4000HP in Sweep Mode



Mini-Circuits USB Synthesized Signal Generator ...

Main Sweep Mode Hop Mode Multi Gen. Control

Frequency: MHz Power: dBm

Frequency Sweep
 Power Sweep

Frequency MHz Start 500 Stop 1000 Step Size: 1 MHz

Continuous Sweep Power dBm 0
 Reverse Sweep

Extra Freq MHz: 505.55,788, 995.65

Wait for Trigger (Low) Set Trigger Out (High)

Dwell Time: 50 mSec (min 50 mSec)

Start
Click to change status

Generator Model: SSG-4000HP Serial Number: 11108090008

Always on top
 Compact View

SSG-4000HP in Hop Mode



Mini-Circuits USB Synthesized Source Generator (Ver A1)

Main Sweep Mode **Hop Mode**

Frequency MHz	Power dBm
900	-10
905	-9
910	-8
915	-7
920	-6
925	-5
930	-4
935	-3
940	-2
945	-1
950	0
955	1

Power: -50 dBm

Frequency Hop MHz
 Power Hop dBm

Continuous Hop
 Reverse Hop

Trigger Out 1 mSec

Dwell Time 1000 mSec

Generator Model: SSG-4000HP Serial Number: PROTOTYPE

Always on top
 Compact View

Start

SSG-4000HP Multi-generator Control



Multi Generators Sweep Control
✕

Freq Sweep
 Power Sweep Continuous Mode

Select Generators:	S/N:	Start (MHz):	Stop (MHz):	Power (dBm):	No Of Points:
<input checked="" type="checkbox"/> Generator 1:	<input type="text" value="11108090008"/>	<input type="text" value="350"/>	<input type="text" value="550"/>	<input type="text" value="0"/>	<input type="text" value="20"/>
<input checked="" type="checkbox"/> Generator 2:	<input type="text" value="11108090011"/>	<input type="text" value="450"/>	<input type="text" value="650"/>	<input type="text" value="5"/>	
<input type="checkbox"/> Generator 3:	<input type="text"/>	<input type="text"/>	<input type="text"/>	<input type="text"/>	
<input type="checkbox"/> Generator 4:	<input type="text"/>	<input type="text"/>	<input type="text"/>	<input type="text"/>	

Gen-1		Gen-2	
(MHz)	(dBm)	(MHz)	(dBm)
350.000	0.00	450.000	5.00
360.526	0.00	460.526	5.00
371.053	0.00	471.053	5.00
381.579	0.00	481.579	5.00
392.105	0.00	492.105	5.00
402.632	0.00	502.632	5.00
413.158	0.00	513.158	5.00
423.684	0.00	523.684	5.00
434.211	0.00	534.211	5.00
444.737	0.00	544.737	5.00
455.263	0.00	555.263	5.00
465.789	0.00	565.789	5.00
476.316	0.00	576.316	5.00
486.842	0.00	586.842	5.00
497.368	0.00	597.368	5.00
507.895	0.00	607.895	5.00

Dwell Time (ms):
(min 50 mSec)

Turn RF ON at Start
 Turn RF OFF at Stop

SSG-4000 2 Tone Generator Setup

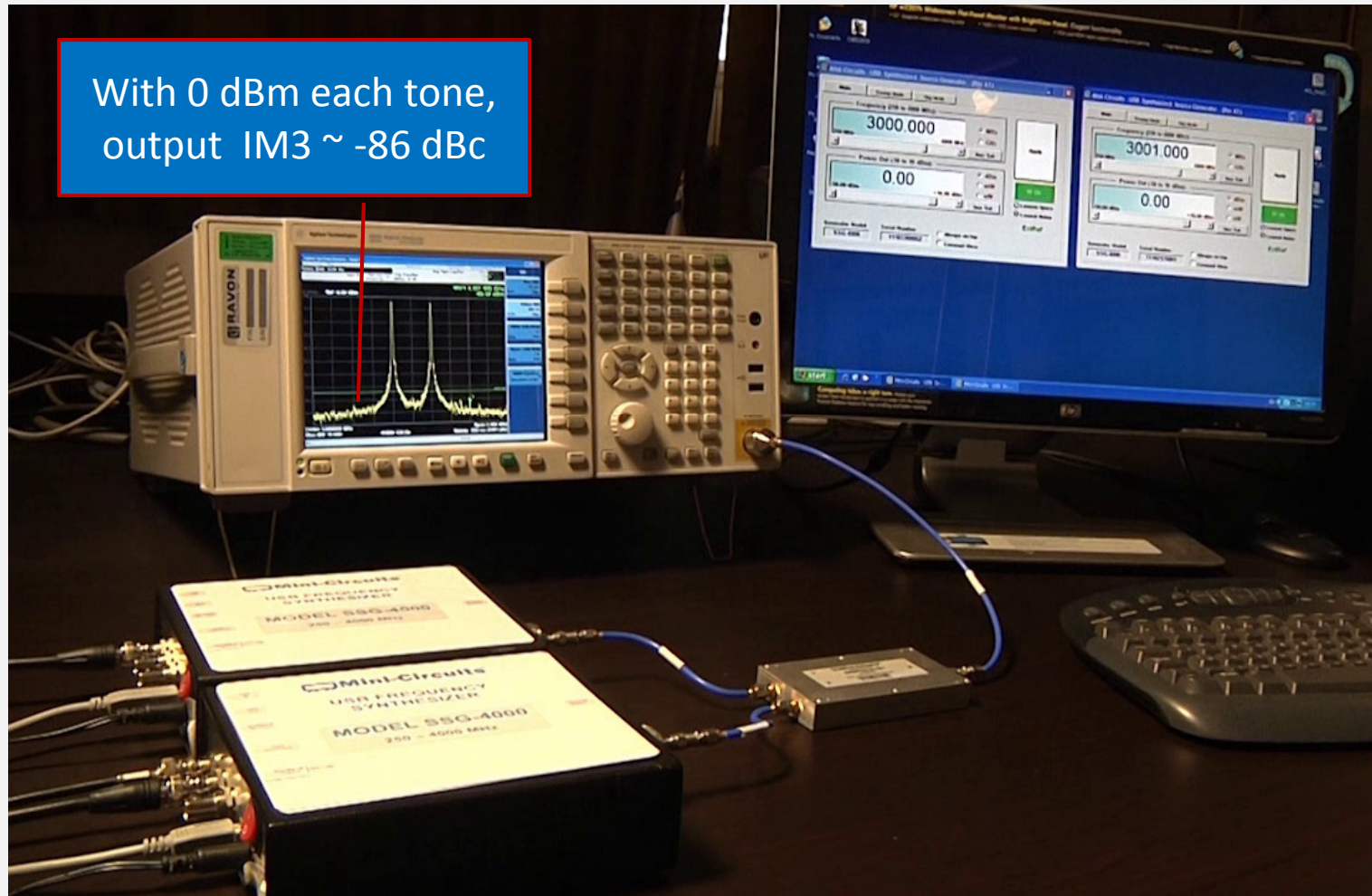

SSG-4000HP Typical Performance

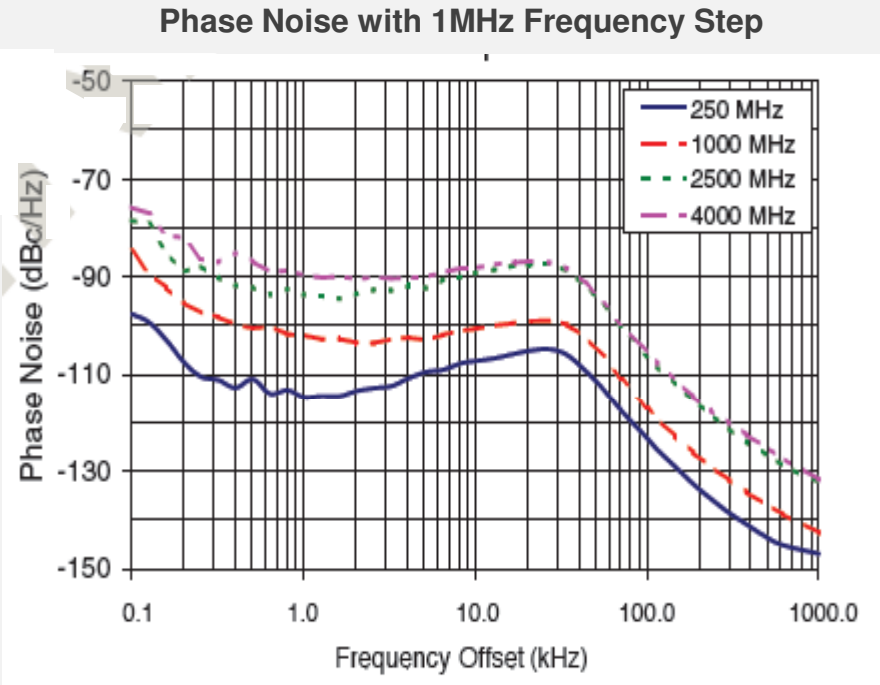
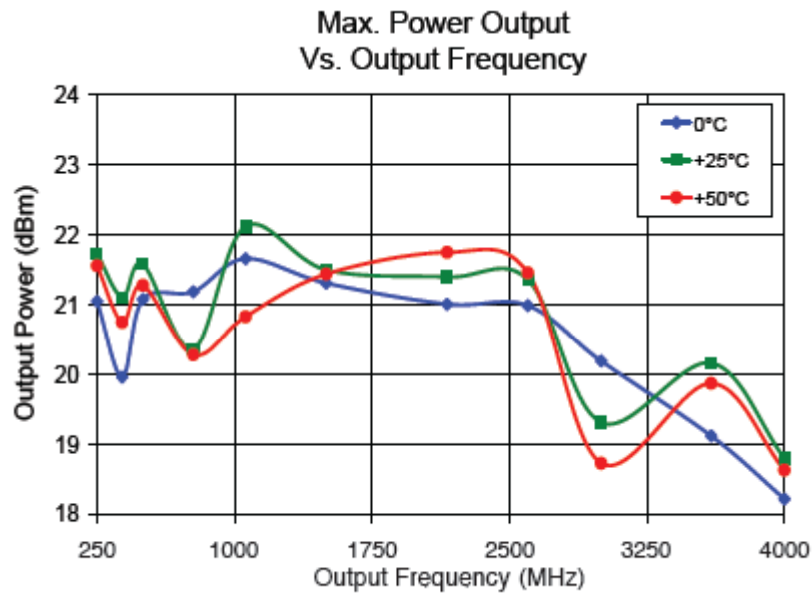

USB Electro-mechanical Switch Matrices



USB-1SPDT-A18



USB-2SPDT-A18



USB-3SPDT-A18



USB-4SPDT-A18

Advantages of USB-4SPDT Switch Matrices



Cooling fan controlled by internal temperature sensor allows the unit to operate continuously with no down time

The Big Deal

- Capable of 100 million cycles
- Wide frequency range (DC to 18 GHz)
- 4 SPDT electromechanical, absorptive RF switches configurable into (a) SP3T (b) SP4T (c) SP5T (d) DPDT, 3PDT, 4PDT and (e) transfer switches

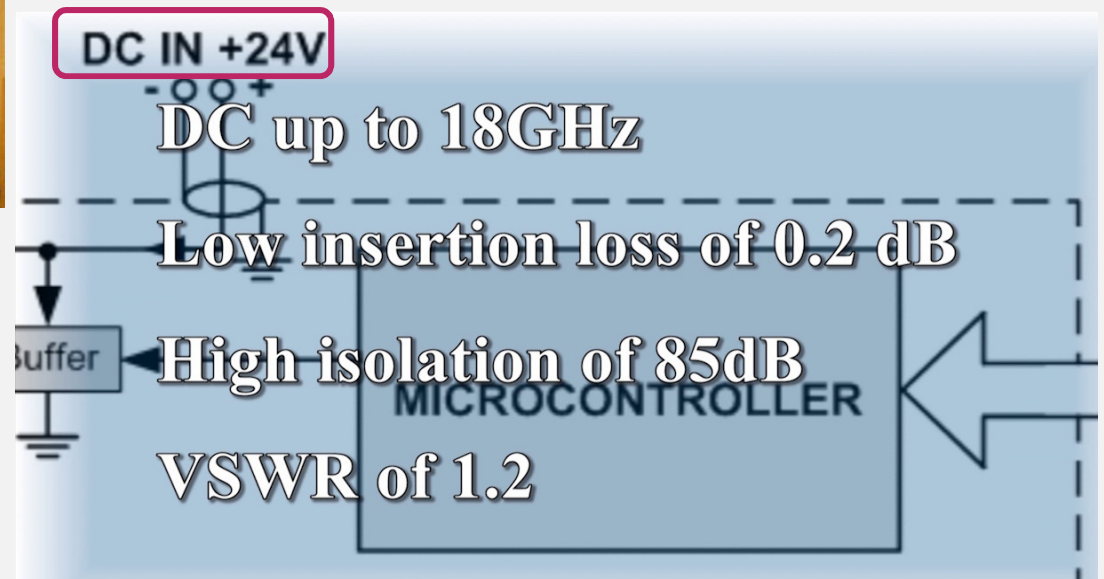

Versatility of USB-4SPDT Switch Controller



With our smart GUI, you can choose one of our standard configurations with just one click of a button.

Mini-Circuits - USB RF Switch Controller (Ver A7)

'Free Control' - ON/OFF for every switch

DE - ENERGIZED

RF Switch A
Mini-Circuits MSP2TA-18

DE - ENERGIZED

RF Switch B
Mini-Circuits MSP2TA-18

DE - ENERGIZED

RF Switch D
Mini-Circuits MSP2TA-18

DE - ENERGIZED

RF Switch C
Mini-Circuits MSP2TA-18

Model Name:
USB-4SPDT-A18

Serial Number:
11108080005

Address (1 to 255):
255 Set

Standard Switch Configurations

- Use as 4PDT Switch
- Use as 3PDT & SPDT Switches
- Use as two DPDT Switches
- Use as SP5T Switch
- Use as SP4T & SPDT Switches
- Use as Two SP3T Switches
- Use as Transfer Switch

User Sequence

USB-4SPDT as Dual SP3T Switches

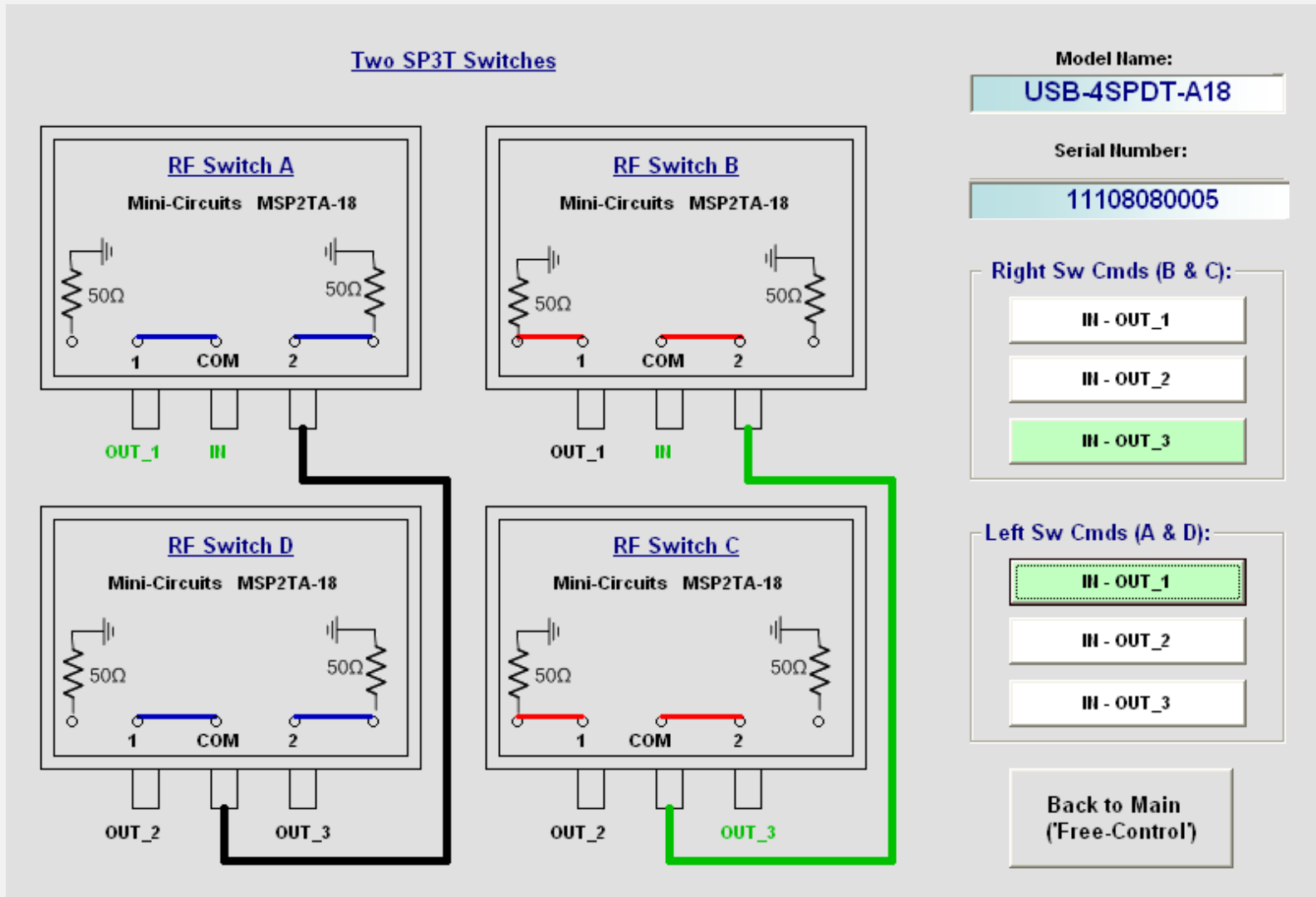

USB-4SPDT User Defined Switching Sequences



USER SWITCHING SEQUENCE

Model Name: **USB-4SPDT-A18**

Serial Number: **11108080005**

Serial Number: **11108080005**

Set Name:

Step	SW A	SW B	SW C	SW D	dwll (mSec)	Exec Program
Step 1	COM->1	COM->1	COM->1	COM->1	270	
Step 2	COM->2	COM->2	COM->1	COM->1	350	
Step 3	COM->1	COM->2	COM->1	COM->1	500	
Step 4	COM->2	COM->1	COM->2	COM->1	1000	

User can also define the switching sequence, dwell time for each step, # switching cycles to suit their specific applications

Run Sequence: View Switches

Count Limit: Counter:

Time Limits(min): Elapsed (min):

Current Step

Continuously

Stop

USB-4SPDT-A18

Cabling configuration can be saved and recalled to save set up time and eliminate operator's error

USB Frequency Counter UFC-6000



The UFC-6000 counter is a handheld device that can be operated without software.

Connecting the counter to a laptop via USB connection provides an additional display and data collection capability.

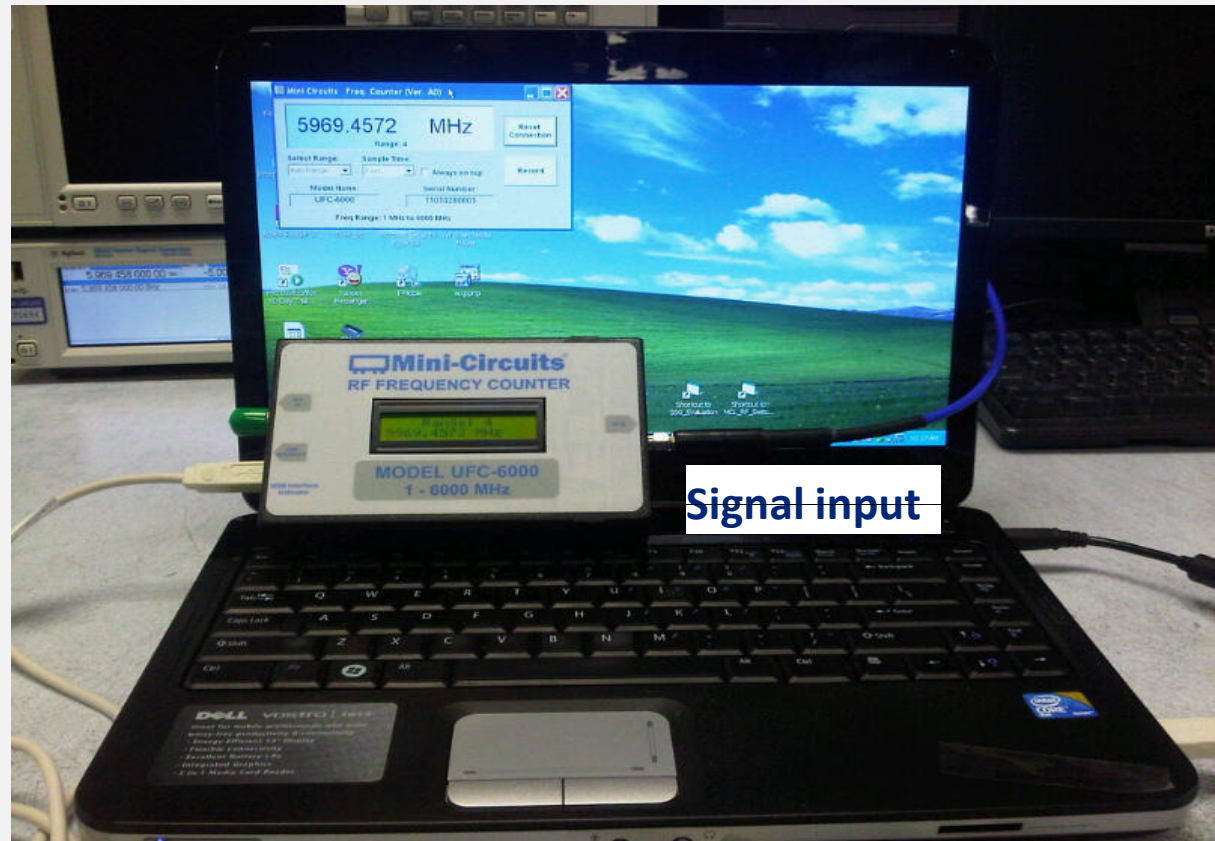

Operating Frequency: 1 – 6000 MHz
Dynamic Range: -28 to +13dBm

USB Frequency Counter UFC-6000 Precision

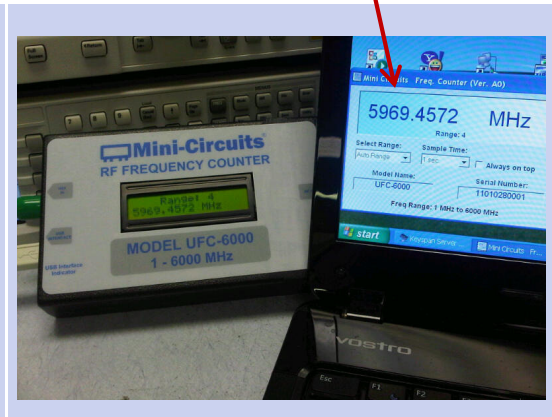
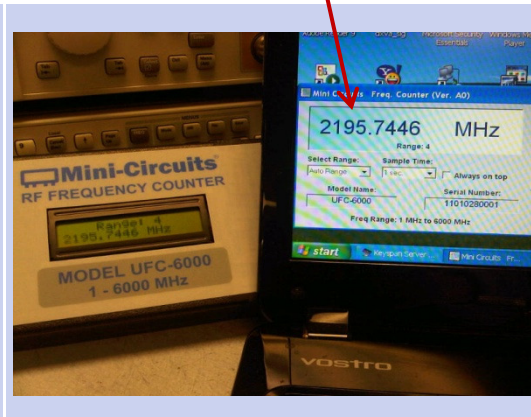
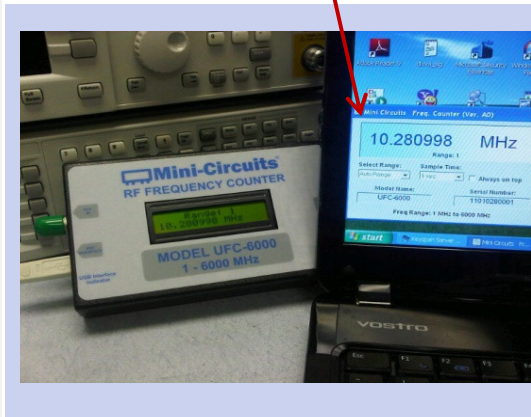
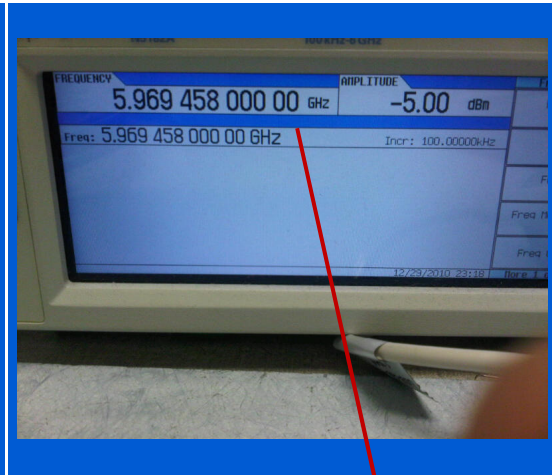
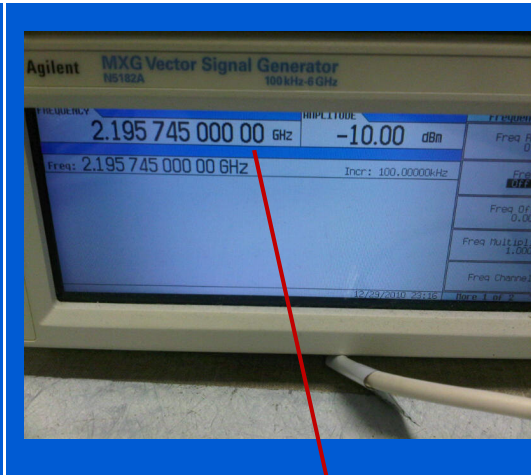
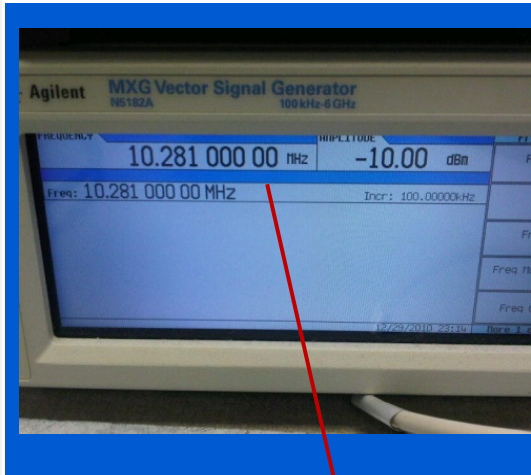



Features	Description
USB HID (Human Interface Device)	Plug-and-Play (no device driver required)
16 digital I/O lines in 2 bytes of 8 channels each	Accessible through a single 26 pin IDC type connector, these channels can sink/source upto 80mA total. Each digital I/O byte can operate as Input or Output independently
8 relays with dry contact outputs	Accessible through a 34 pin IDC type connector, these relays support an AC load of 125VAC at 0.5A or DC load of 24VDC at 1A and use approximately 25mA
Selectable TTL voltage	Either 3.3V (LVTTTL) or 5V (TTL) can be selected through an external switch
Power consumption 500mA max at 5V	All required power from the USB bus

USB-I/O-16D8R Software GUI



Mini-Circuits USB To I/O - (Ver A0)

Config Digital Byte A
 Byte A as Output
 Byte A as Input

Config Digital Byte B
 Byte B as Output
 Byte B as Input

Model Name: **USB-I/O-16D8R**
Serial Number: **11010100004**

Set Output

Set Relays
0 1 2 3 4 5 6 7

Relays Status:
0 1 2 3 4 5 6 7

Set Digital Byte A
0 1 2 3 4 5 6 7

Byte A Status:
0 1 2 3 4 5 6 7

Set Digital Byte B
0 1 2 3 4 5 6 7

Byte B Status:
0 1 2 3 4 5 6 7

Digital SPI Out
Binary Word to Send: MSB LSB
Send

Clock Bit:
Data Bit:
LE Bit:

Pulse width (us):

Digital Legend
Red - "Low"
Green - "High"

Relays Legend
Red - Common to NC
Green - Common to NO

USB-I/O-16D8R Applications

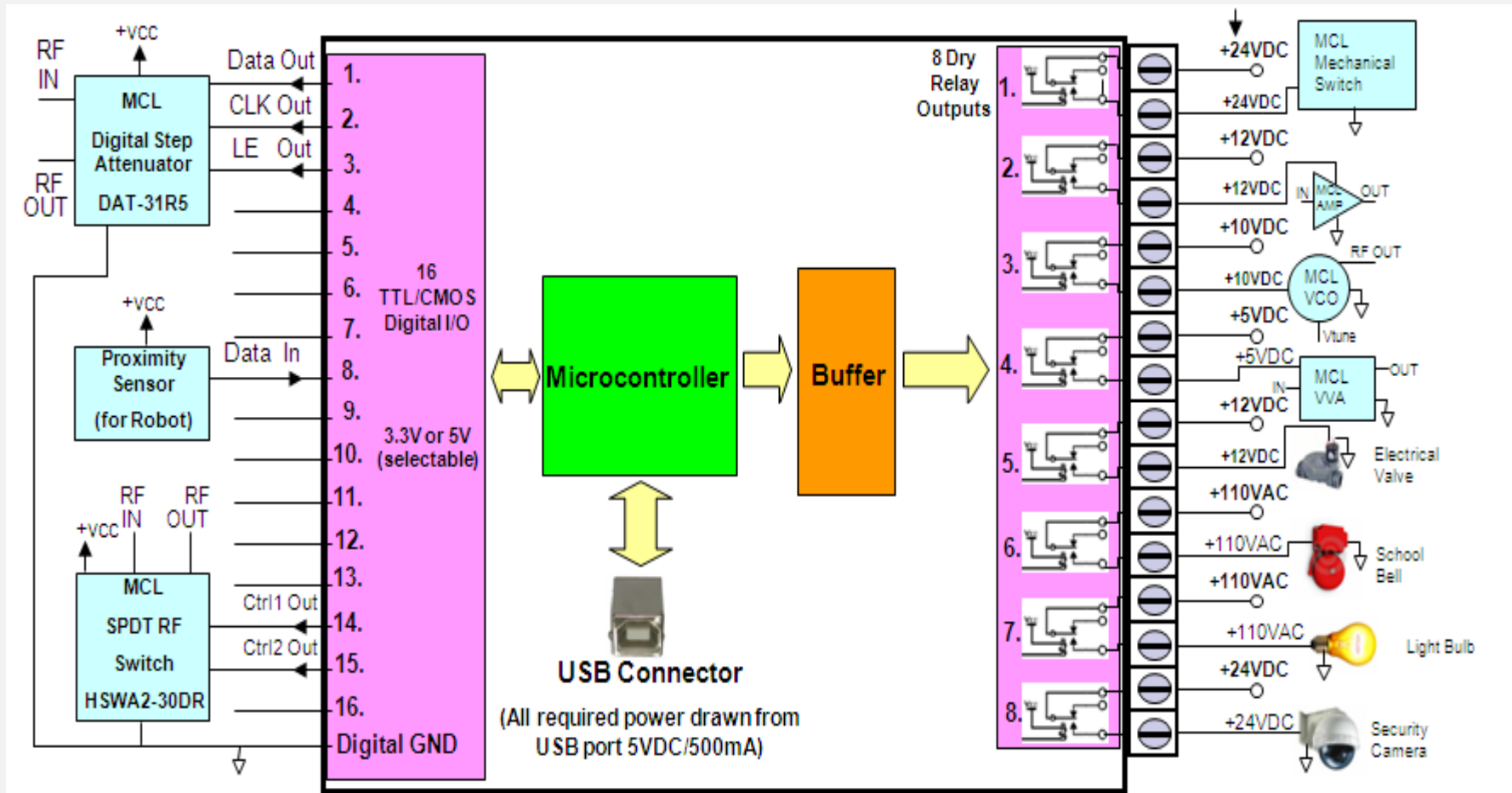

USB to SPI Converter - Digital Step Attenuator

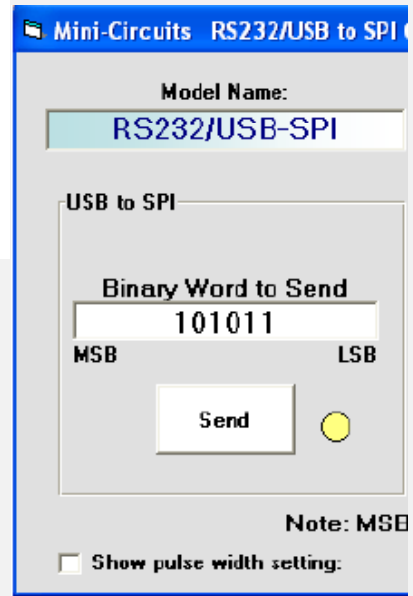
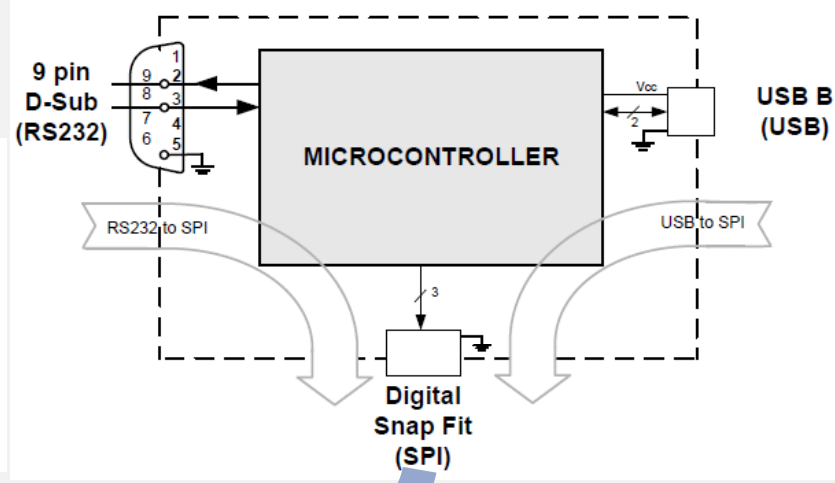

Pin Connections

PIN Number	Function
3	Load Enable
7	Clock
9	Data out
2,5,8	GND

Smart Power Sensor



Dynamic Range -30 to +20dBm

**Frequency Bandwidth
9KHz up to 8000MHz
Impedance 50Ω**

**Frequency 100KHz - 2500MHz
Impedance 75Ω**

Smart Power Sensor Products



Key Features

- *USB HID device compatible with 32/64 Bit operating systems (no driver required)*
- *Includes measurement application GUI software with API-DLL com object*
- *Compatible with NI LabVIEW®, Delphi®, Borland C++, C#, VC++, VB®, MATLAB®, Agilent VEE®, Python and .Net*
- *High speed measurement capability 10 msec typical (PWR-8FS)*
- *No calibration required before taking measurement*
- *Multi-sensor capability*

PWR-4GHS	50Ω	9 kHz to 4000 MHz
PWR-6GHS	50Ω	1 to 6000 MHz
PWR-8FS	50Ω	1 to 8000 MHz
PWR-8GHS	50Ω	1 to 8000 MHz
PWR-2.5GHS-75	75Ω	100 kHz to 2500 MHz



Smart Power Sensor Applications Software



Mini-Circuits Smart RF Power Meter (Ver B11)

Format: dBm Watt

Device Temp: +25.00°C

Freq (1 - 8000 MHz): 1800

Fastest
Faster
Low Noise

Reading: -13.81 dBm

Averaging: Avg. Count: 100

Offset Val.: 0.00 (dB)

Offset File: Ignore

Relative: 0.00 dBm

Rel. Table:

Sensor Model: PWR-SEN-8FS

Serial Number: 11109190009

Compact View
Always on top

Buttons: Add Sensor, Reset Connection, Record, Measurement Applications

Meas. Applications

Recall Setup

Sensor Serial Number: 11109190009

Measurement Applications

1. - Power Measurement of source
2. - High Power Measurement using Virtual Coupler (Up to +53 dBm)
3. - Continuous Power Monitoring Measurement (Low or High)
4. - Calibrating a Coupler (Extending Frequency range of a coupler by converting to Virtual Coupler)
5. - Calibrating an Attenuator (Normalizing attenuation to nominal value by converting to Virtual Attenuator)
6. - Insertion Loss - 2 Port device (Attenuator, Filter, etc)
7. - Insertion Loss - 3 Port device (2 Way Splitter, Coupler)
8. - Gain
9. - Return Loss Measurement Using Coupler
10. - Calibrating Thru-Path (Create Offset File of Gain/Loss Path)

Buttons: Back, Next

Filter I. Loss & R. Loss Test Set Up

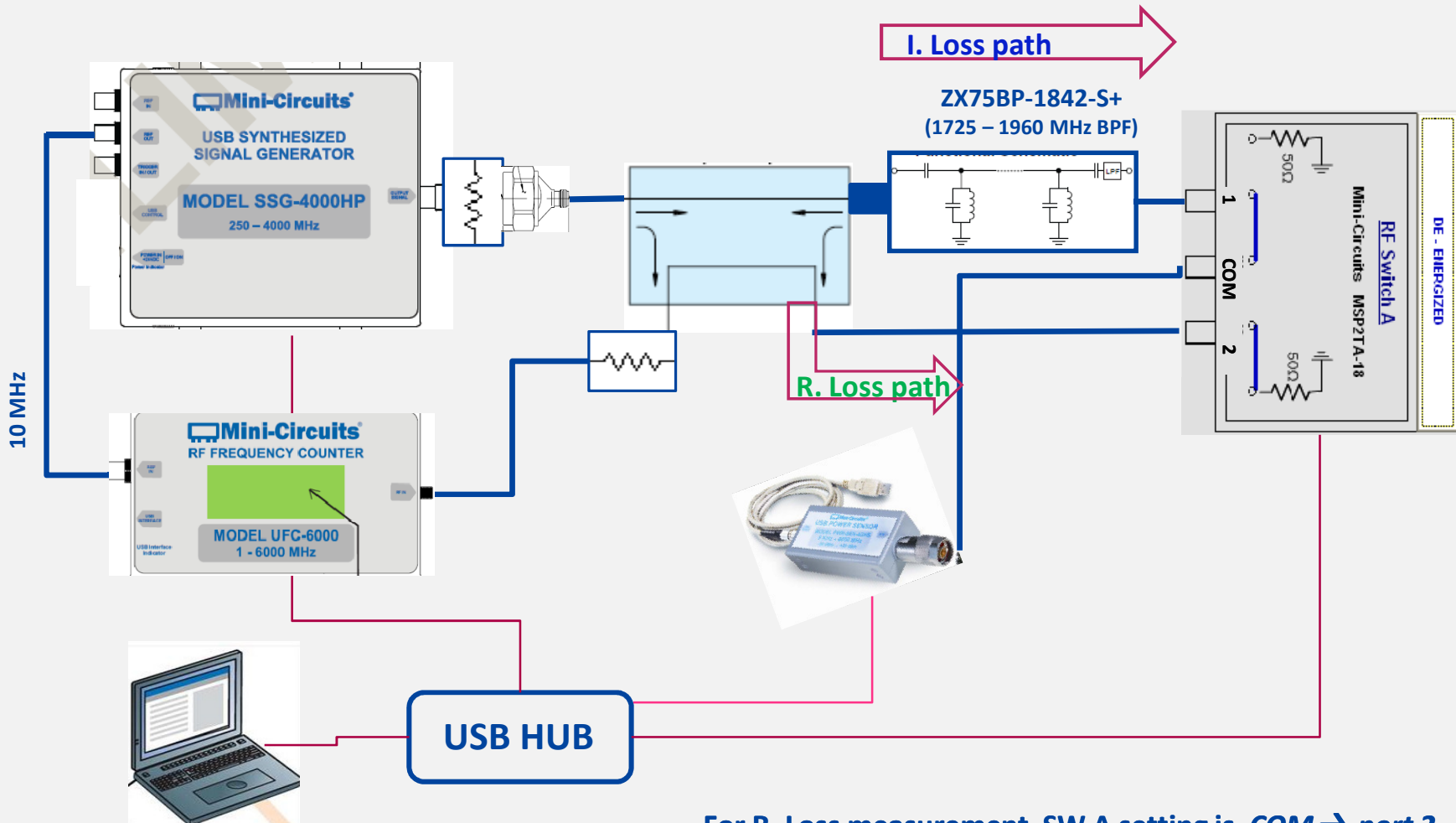

Filter Insertion Loss Measurement



Project: Filter Insertion Loss

Back New Proj Recall Save Print Data Setup

Sensor Serial Number: 11109190009

Model Name: ZX75BP-1842-S+

Run No.:

Application: Insertion Loss 2 Port

I.LOSS Measurement

Step 1: Power Reference In

Step 2: D.U.T Measurement

Avg: 8 Faster Mode

#	Freq (MHz)	Source Pwr (dBm)	PwrRef In (dBm)	Read Pwr (dBm)	I.Loss (dB)	Min (dB)	Max (dB)	Pass/Fail	Safe Att. (dB)
1	1450.000000	18.00	4.68	-35.20	-39.88				
2	1461.000000	18.00	4.48	-33.95	-38.43				
3	1472.000000	18.00	4.54	-31.16	-35.70				
4	1483.000000	18.00	4.33	-29.45	-33.78				
5	1494.000000	18.00	4.30	-27.32	-31.62				
6	1505.000000	18.00	4.21	-24.96	-29.17				
7	1516.000000	18.00	3.94	-22.74	-26.68				
8	1527.000000	18.00	3.69	-20.40	-24.09				
9	1538.000000	18.00	3.68	-17.90	-21.58				
10	1549.000000	18.00	3.49	-15.88	-19.37				
11	1560.000000	18.00	3.31	-14.13	-17.44				
12	1571.000000	18.00	3.39	-12.40	-15.79				
13	1582.000000	18.00	3.29	-10.95	-14.24				
14	1593.000000	18.00	3.26	-9.46	-12.72				
15	1604.000000	18.00	3.50	-7.75	-11.25				
16	1615.000000	18.00	3.56	-6.23	-9.79				

Run Stop Continuous Mode Display On-Line Graph D.U.T. No: 1 DUT Serial No:

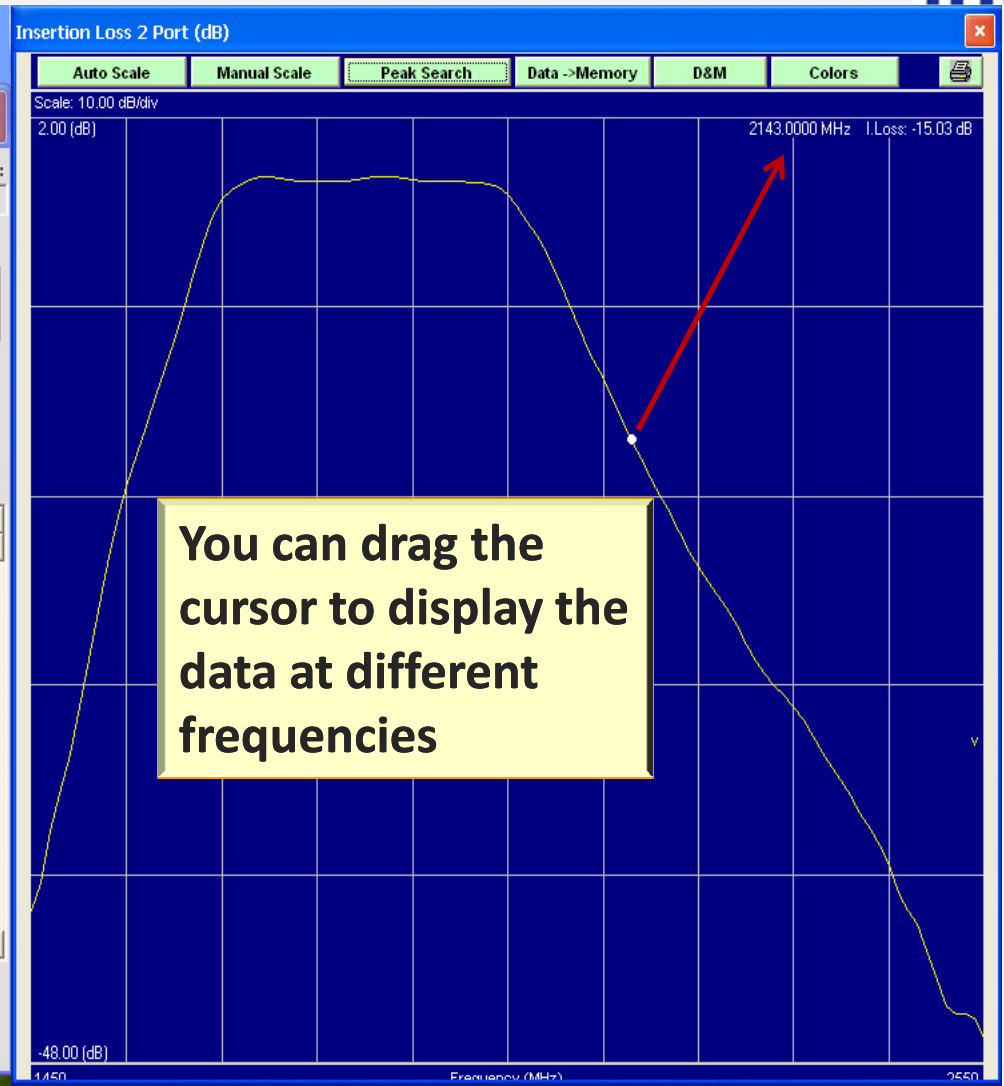

Filter Return Loss Measurement



Project: Filter Return Loss

Back New Proj Recall Save Print Data Setup

Sensor Serial Number: 11109190009

Model Name: ZX75BP-1842-S+

Run No.:

Application: Return Loss

R.LOSS Measurement

Step 1: Return Loss Reference

Step 2: D.U.T Measurement

Avg. 8 Faster Mode

#	Freq (MHz)	Source Pwr (dBm)	PwrRef In (dBm)	Read Pwr (dBm)	Measured R.Loss (dB)	R.Loss Spec Min (dB)	R.Loss Spec Max (dB)	Pass/Fail	Safe Att. (dB)
17	1626.000000	18.00	-6.38	-10.52	-4.14		-10.0	Fail	
18	1637.000000	18.00	-6.56	-11.19	-4.63		-10.0	Fail	
19	1648.000000	18.00	-6.72	-11.94	-5.22		-10.0	Fail	
20	1659.000000	18.00	-6.84	-12.81	-5.97		-10.0	Fail	
21	1670.000000	18.00	-6.97	-13.83	-6.86		-10.0	Fail	
22	1681.000000	18.00	-6.79	-14.37	-7.58		-10.0	Fail	
23	1692.000000	18.00	-6.84	-15.24	-8.40		-10.0	Fail	
24	1703.000000	18.00	-6.86	-15.79	-8.93		-10.0	Fail	
25	1714.000000	18.00	-6.87	-16.64	-9.77		-10.0	Fail	
26	1725.000000	18.00	-6.74	-17.13	-10.39		-10.0	Pass	
27	1736.000000	18.00	-6.71	-17.45	-10.74		-10.0	Pass	
28	1747.000000	18.00	-6.67	-17.17	-10.50		-10.0	Pass	
29	1758.000000	18.00	-6.63	-17.05	-10.42		-10.0	Pass	
30	1769.000000	18.00	-6.51	-17.00	-10.49		-10.0	Pass	
31	1780.000000	18.00	-6.46	-17.22	-10.76		-10.0	Pass	
32	1791.000000	18.00	-6.36	-18.07	-11.71		-10.0	Pass	

Run Stop Continuous Mode Display On-Line Graph

D.U.T. No: 1 DUT Serial No.:

brprzfp Shortcut to Outlook backups

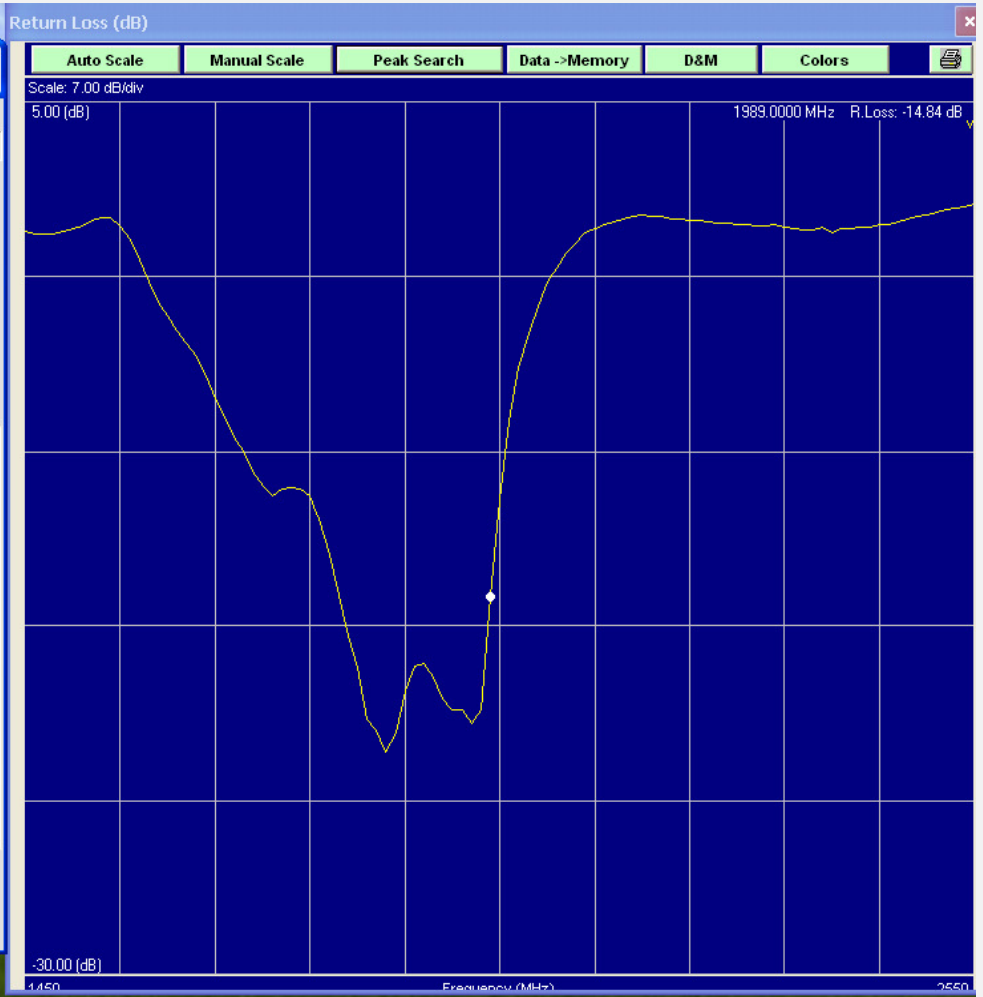

2 Port S_{11} & S_{12} - Universal Setup

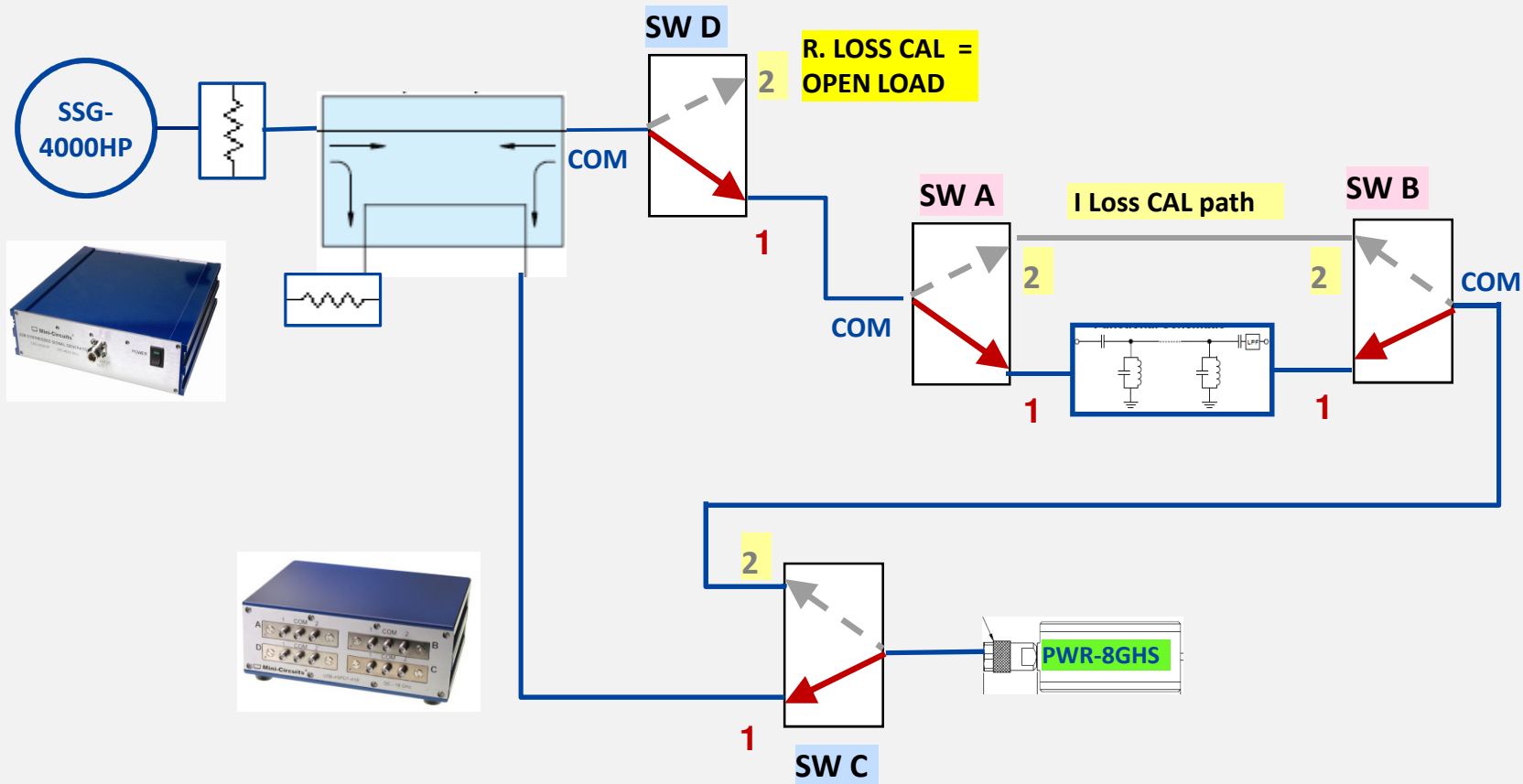

Filter S11 & S12 - Switch Sequence



USER SWITCHING SEQUENCE

Model Name: **USB-4SPDT-A18** Serial Number: **11111010001**

Set Name: **IL RL SINGLE SETUP**

Step	SW A	SW B	SW C	SW D	dwll (mSec)	Exec Program
RL CAL	COM->1	COM->1	COM->1	COM->2	3000	
RL TEST	COM->1	COM->2	COM->1	COM->1	3000	
IL CAL	COM->2	COM->2	COM->2	COM->1	3000	
IL TEST	COM->1	COM->1	COM->2	COM->1	3000	

Buttons: Add, Insert, Remove

Run Sequence: Count Limit: Counter: View Switches

USB-4SPDT-A18

S11 CAL & Test (Switch Seq #1 & #2)



S12 CAL & Test (Switch Seq #3 & #4)

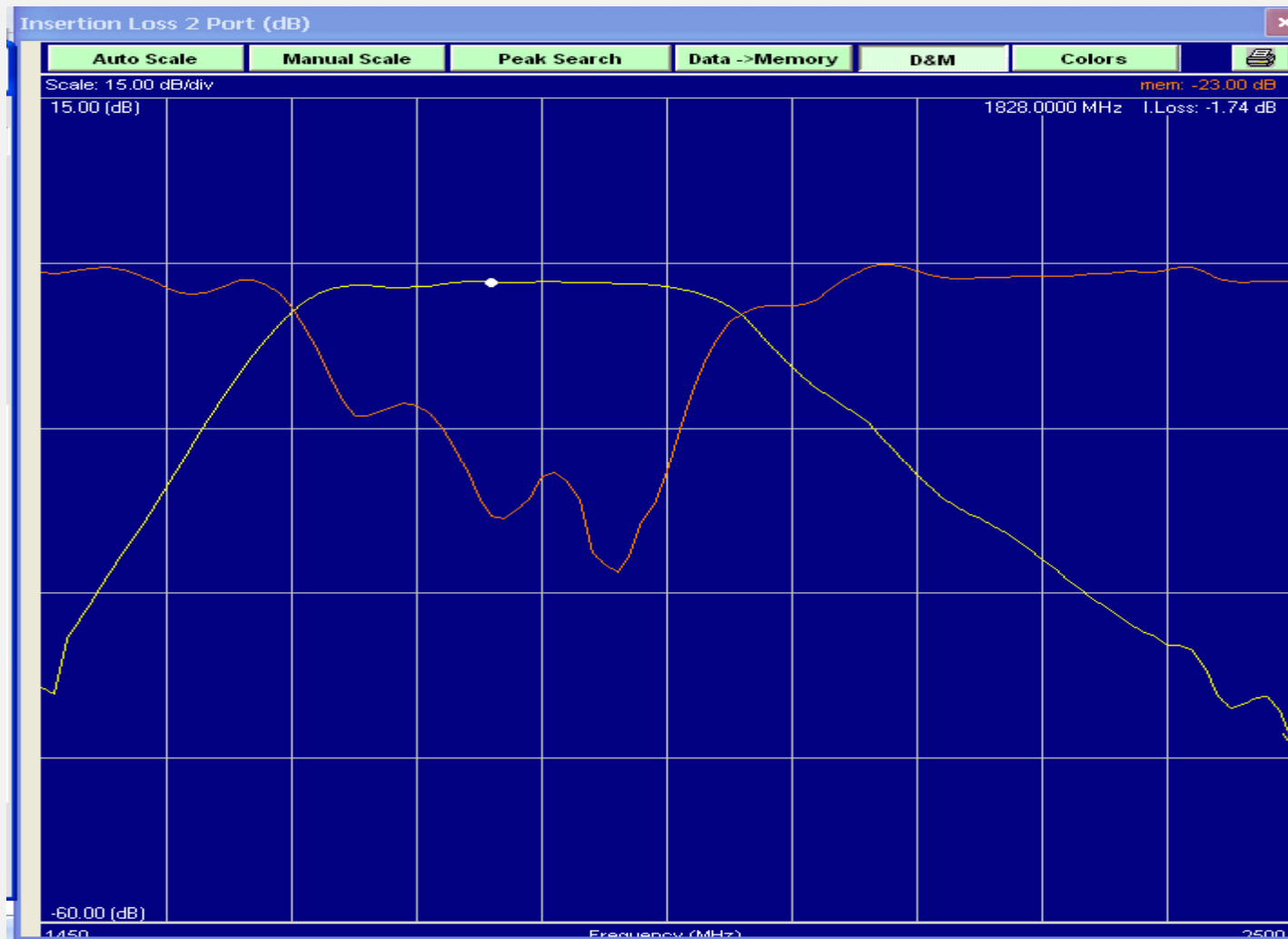

Custom High Speed 5 Port Tester

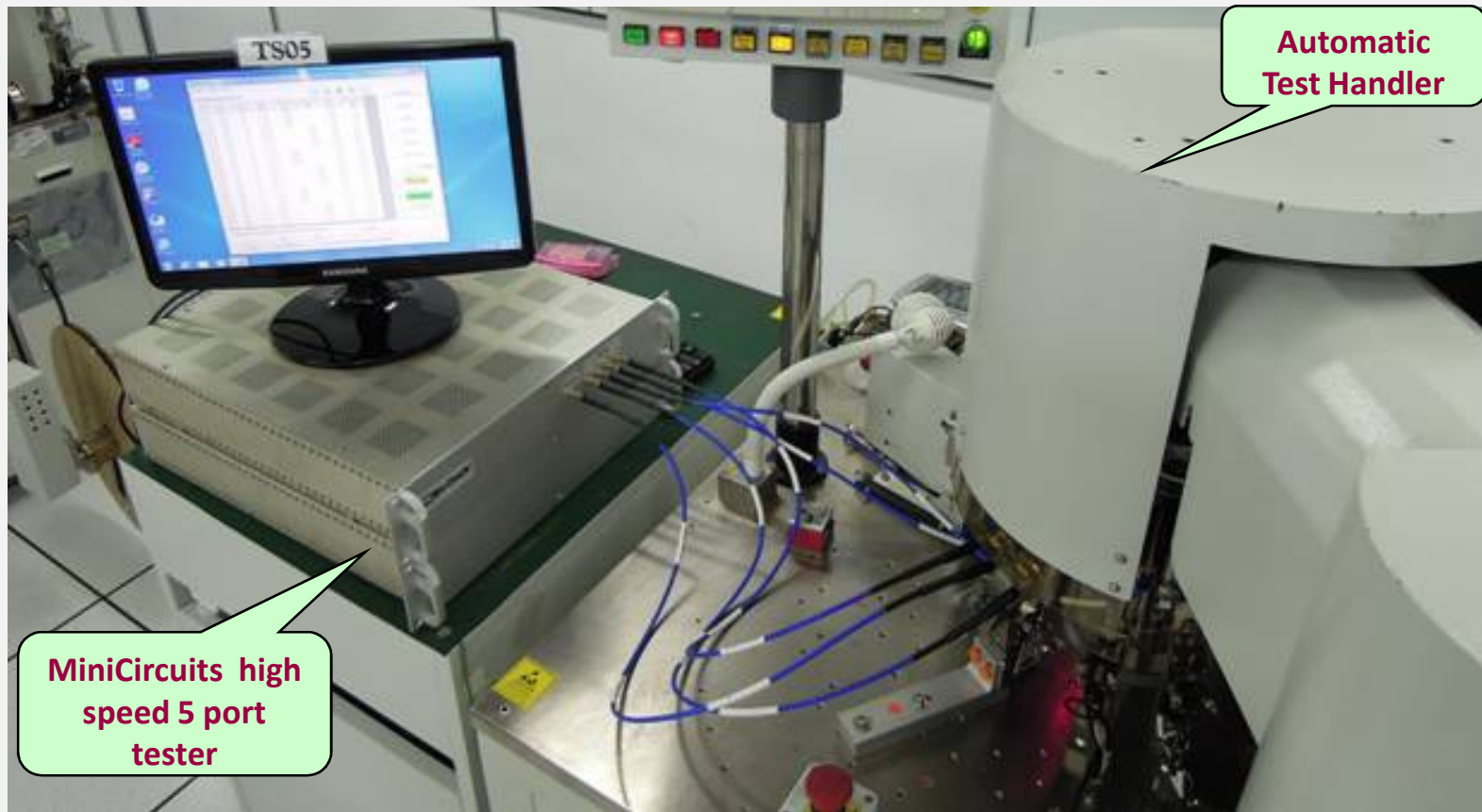

High Speed 4 way Splitter Tester

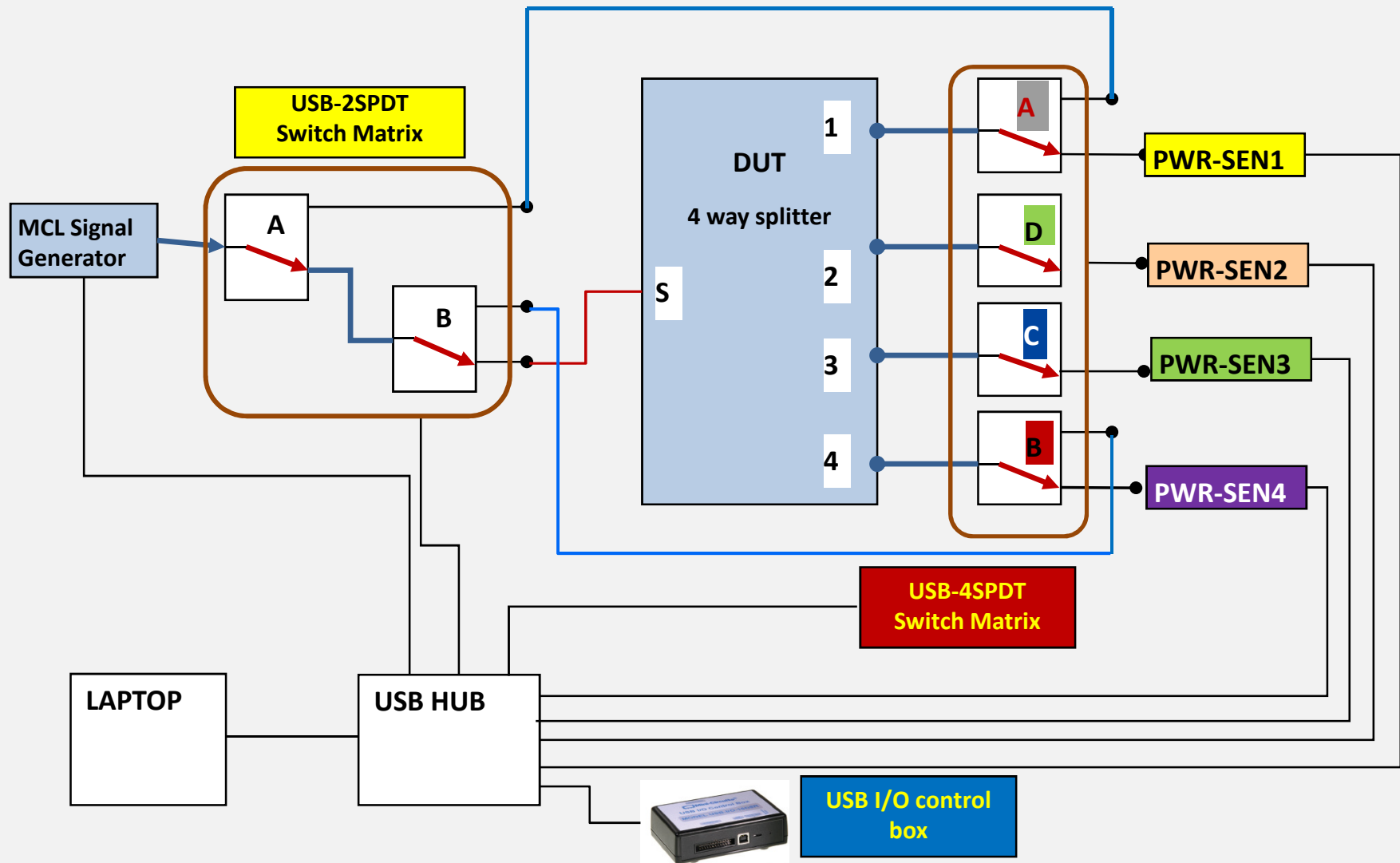

Verifying Test speed vs Input Power Level



Meas. Name	Freq. (MHz)	Agilent NA Reference Reading	Measurements when Input Power is			
			+5 dBm	+10 dBm	+15 dBm	+18 dBm MCL Test Plan
Insertion Loss S-1	1215	-7.90	-8.13	-7.92	-7.75	-8.05
Insertion Loss S-2	1215	-7.95	-8.08	-8.00	-7.75	-7.97
Insertion Loss S-3	1215	-7.97	-8.1	-8.01	-7.80	-8.04
Insertion Loss S-4	1215	-7.89	-8.03	-7.95	-7.47	-7.92
Isolation 1-2	1215	-21.61	-21.89	-21.87	-21.46	-21.87
Isolation 1-3	1215	-20.45	-20.66	-20.67	-20.27	-20.60
Isolation 1-4	1215	-22.09	-22.26	-22.33	-21.90	-22.26
Isolation 4-2	1215	-20.59	-20.78	-20.79	-20.31	-20.71
Isolation 4-3	1215	-21.59	-21.75	-21.81	-21.32	-21.76
Insertion Loss S-1	1315	-7.26	-7.29	-7.21	-7.54	-7.29
Insertion Loss S-2	1315	-7.28	-7.26	-7.25	-7.56	-7.20
Insertion Loss S-3	1315	-7.31	-7.29	-7.27	-7.60	-7.27
Insertion Loss S-4	1315	-7.26	-7.24	-7.24	-7.53	-7.46
Isolation 1-2	1315	-26.10	-25.76	-25.7	-26.08	-26.24
Isolation 1-3	1315	-24.14	-23.94	-23.92	-24.13	-24.21
Isolation 1-4	1315	-26.32	-25.83	-25.94	-26.36	-26.38
Isolation 4-2	1315	-24.24	-23.86	-24.02	-24.15	-24.25
Isolation 4-3	1315	-25.99	-25.42	-25.58	-25.87	-25.95
Insertion Loss S-1	1900	-6.97	-6.77	-7.05	-7.00	-7.18
Insertion Loss S-2	1900	-6.87	-6.49	-6.92	-6.89	-6.91
Insertion Loss S-3	1900	-6.89	-6.65	-6.95	-6.92	-7.04
Insertion Loss S-4	1900	-7.01	-6.74	-7.05	-7.05	-7.11
Isolation 1-2	1900	-19.73	-19.72	-20.05	-20.15	-20.17
Isolation 1-3	1900	-19.45	-19.42	-19.80	-19.84	-19.85
Isolation 1-4	1900	-19.07	-19.06	-19.35	-19.41	-19.45
Isolation 4-2	1900	-19.24	-19.32	-19.58	-19.66	-19.66
Isolation 4-3	1900	-19.69	-19.72	-20.16	-20.21	-20.21
Test Time			0.73 s	0.66 s	0.71 s	0.77 s

Production Test Result



Mini-Circuits - 4 Way Power Splitter Measurements (Ver A1)

Project Setup Help

No Of Measurements: 27

Seq #	Freq (MHz)	Power (dBm)	Meas. Name	TSpec_Dn (dB)	TSpec_Up (dB)	Ref CAL. (dB)	Meas. Value (dB)
1	1875	5	I.L. S-1	-07.85		1.88	-7.03
2	1875	5	I.L. S-2	-07.85		1.61	-7.22
3	1875	5	I.L. S-3	-07.85		1.52	-7.16
4	1875	5	I.L. S-4	-07.85		1.20	-6.93
5	1875	5	ISO 1-2		-15.50	1.79	-23.37
6	1875	5	ISO 1-3		-15.50	1.70	-21.41
7	1875	5	ISO 1-4		-15.50	1.44	-21.51
8	1875	5	ISO 4-2		-15.50	1.03	-21.52
9	1875	5	ISO 4-3		-15.50	0.98	-23.14
10	2100	5	I.L. S-1	-07.35		1.51	-6.81
11	2100	5	I.L. S-2	-07.35		1.26	-6.95
12	2100	5	I.L. S-3	-07.35		1.17	-6.91
13	2100	5	I.L. S-4	-07.35		0.83	-6.77
14	2100	5	ISO 1-2		-18.50	1.33	-22.99
15	2100	5	ISO 1-3		-18.50	1.24	-21.80
16	2100	5	ISO 1-4		-18.50	0.94	-21.16
17	2100	5	ISO 4-2		-18.50	0.51	-21.79
18	2100	5	ISO 4-3		-18.50	0.48	-22.90
19	2800	5	I.L. S-1	-07.35		1.02	-6.93
20	2800	5	I.L. S-2	-07.35		0.79	-7.09
21	2800	5	I.L. S-3	-07.35		0.69	-7.05
22	2800	5	I.L. S-4	-07.35		0.32	-7.06
23	2800	5	ISO 1-2		-18.00	0.94	-19.64
24	2800	5	ISO 1-3		-18.00	0.80	-19.20
25	2800	5	ISO 1-4		-18.00	0.43	-18.62
26	2800	5	ISO 4-2		-18.00	0.15	-19.13
27	2800	5	ISO 4-3		-18.00	0.12	-19.55

Note: Insertion Loss Meas. includes the 6dB theoretical loss.

D.U.T. No: 1175

Initialize Run Stop

Calibrate Run Continuously Communicate With Test Handler Machine

Model Name: WP4U1+

Run No.: -

Lot No.: 8327P042SEF4-03

Qty tested: 7972

Tested By: PK

Date Tested: 7 DEC 11

Status: G. Info.

Current Unit: Ready

Last Unit: PASS

Cycle Time (Sec): 0.65

Production Throughput Improvement

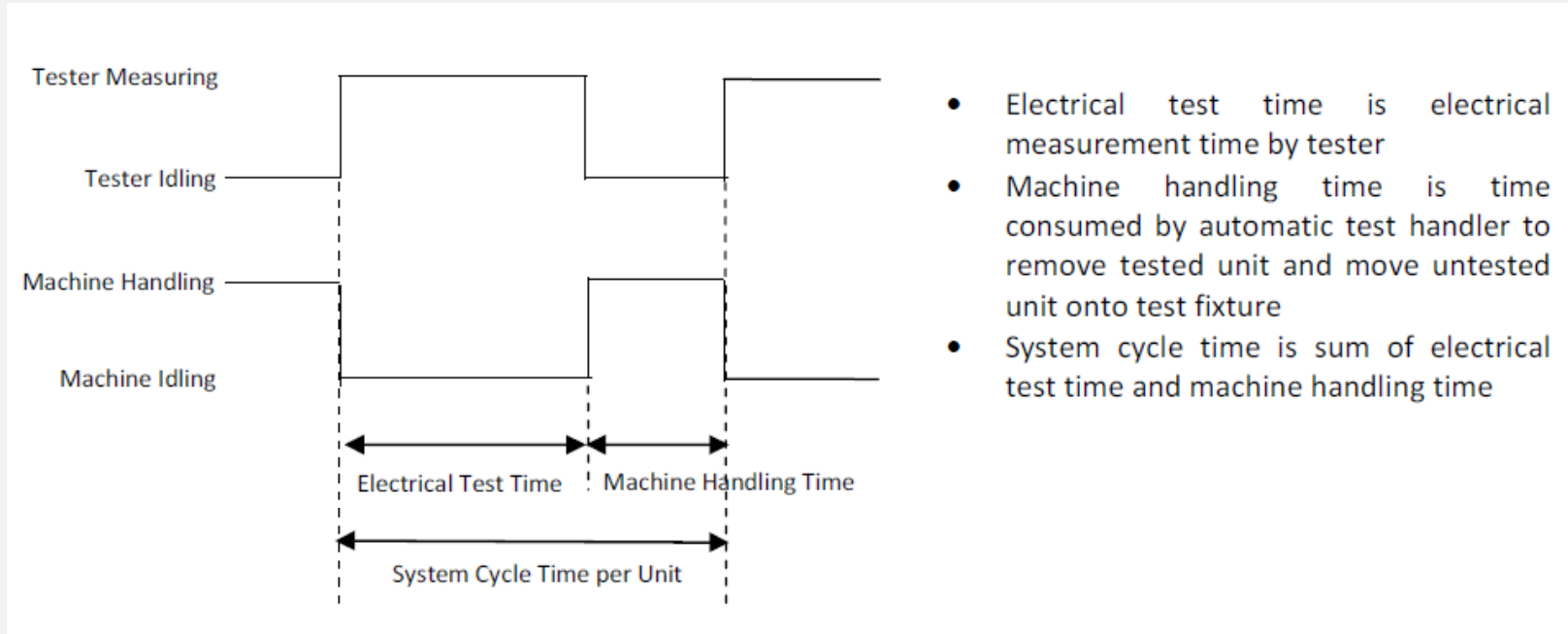

- Electrical test time is electrical measurement time by tester
- Machine handling time is time consumed by automatic test handler to remove tested unit and move untested unit onto test fixture
- System cycle time is sum of electrical test time and machine handling time

Figure 1: Electrical test time, machine handling time and total system cycle time

Tester	Electrical Test Time (sec)	Machine Handling Time (sec)	System Cycle Time (sec)	UPH
New 4-port Power Splitter Tester	0.70**	0.26	0.96	3750
Existing tester	1.50	0.26	1.76	2040

Table 1: Summary of throughput comparison between new tester and Existing tester

Economics 101

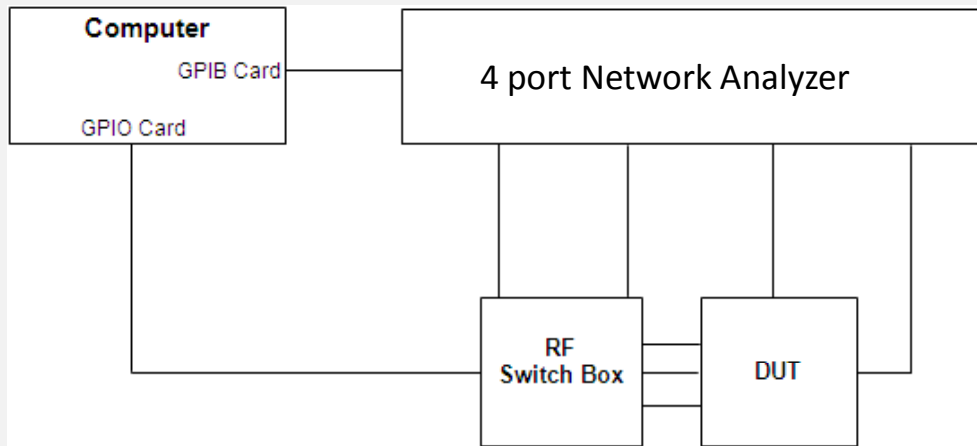

- ⇒ *We now achieved the same goal using hardware that cost 70% less*
- ⇒ *We have also increased the throughput by 83%, which means more savings on operation cost*

Production Test Data Report - Statistical



Statistics Summary Per Lot (Average, Min, Max, CPK, Sigma)

- Scope: All Units

- Passed & Failed units

Unit Type: 4 Way Power Splitter

Model Name: 4 Way Power Splitter

Qty Tested: 50

Test Condition: Input Power: +10dBm

Run No: 12

Lot No: w121

Tested By: MS

Date Tested: Feb 22, 2012

Seq #	Freq (MHz)	Power (dBm)	Meas. Name	TSpec_Dn (dB)	TSpec_Up (dB)	Ref CAL. (dB)	Avg. (dB)	Min (dB)	Max (dB)	Sig (dB)
1	1215	10	I.L. S-1	-08.50		7.36	-7.84	-8.01	-7.45	0.12
2	1215	10	I.L. S-2	-08.50		7.08	-7.97	-8.10	-7.86	0.07
3	1215	10	I.L. S-3	-08.50		6.97	-7.89	-8.02	-7.78	0.08
4	1215	10	I.L. S-4	-08.50		6.81	-7.84	-7.98	-7.73	0.08
5	1215	10	ISO 1-2		-14.50	7.16	-22.06	-22.89	-20.71	0.57
6	1215	10	ISO 1-3		-14.50	7.03	-20.99	-21.56	-20.42	0.40
7	1215	10	ISO 1-4		-14.50	6.86	-22.72	-23.39	-22.10	0.48
8	1215	10	ISO 4-2		-14.50	6.51	-21.22	-21.83	-20.64	0.44
9	1215	10	ISO 4-3		-14.50	6.37	-22.14	-22.82	-21.46	0.49
10	1315	10	I.L. S-1	-07.80		7.25	-7.15	-7.27	-7.06	0.06
11	1315	10	I.L. S-2	-07.80		6.98	-7.23	-7.33	-7.15	0.06
12	1315	10	I.L. S-3	-07.80		6.86	-7.23	-7.35	-7.15	0.06
13	1315	10	I.L. S-4	-07.80		6.69	-7.18	-7.29	-7.10	0.06
14	1315	10	ISO 1-2		-14.50	7.05	-27.36	-28.81	-26.01	0.99
15	1315	10	ISO 1-3		-14.50	6.93	-25.28	-26.28	-24.39	0.65
16	1315	10	ISO 1-4		-14.50	6.75	-27.88	-29.48	-26.41	1.09
17	1315	10	ISO 4-2		-14.50	6.38	-25.29	-26.30	-24.37	0.68
18	1315	10	ISO 4-3		-14.50	6.25	-27.30	-29.04	-25.77	1.09
19	1900	10	I.L. S-1	-07.80		6.77	-7.11	-7.28	-6.96	0.13
20	1900	10	I.L. S-2	-07.80		6.44	-6.99	-7.15	-6.85	0.14
21	1900	10	I.L. S-3	-07.80		6.30	-6.98	-7.13	-6.83	0.13
22	1900	10	I.L. S-4	-07.80		6.06	-7.11	-7.27	-6.97	0.13
23	1900	10	ISO 1-2		-14.50	6.46	-19.98	-20.19	-19.76	0.18
24	1900	10	ISO 1-3		-14.50	6.35	-19.72	-19.99	-19.50	0.19
25	1900	10	ISO 1-4		-14.50	6.12	-19.32	-19.57	-19.09	0.19
26	1900	10	ISO 4-2		-14.50	5.75	-19.60	-19.84	-19.35	0.17
27	1900	10	ISO 4-3		-14.50	5.61	-19.93	-20.13	-19.69	0.17

The Report is Based on:

Total No Of Units: 50

Pass Units: 50

Failed Units: 0

Yield: 100%

Production Test Data Report – Multiple units



Detailed Data Per LOT arange by Units#

- Scope: All Units
- Passed & Failed units

Unit Type: 4 Way Power Splitter
Model Name: 4 Way Power Splitter
Qty Tested: 50
Test Condition: Input Power: +10dBm
Run No: 12
Lot No: w121
Tested By: MS
Date Tested: Feb 22, 2012

Unit No: 1

Seq #	Freq (MHz)	Power (dBm)	Meas. Name	TSpec_Dn (dB)	TSpec_Up (dB)	Ref CAL. (dB)	Meas. Value (dB)
1	1215	10	I.L. S-1	-08.50		7.36	-7.84
2	1215	10	I.L. S-2	-08.50		7.08	-7.94
3	1215	10	I.L. S-3	-08.50		6.97	-7.86
4	1215	10	I.L. S-4	-08.50		6.81	-7.82
5	1215	10	ISO 1-2		-14.50	7.16	-22.24
6	1215	10	ISO 1-3		-14.50	7.03	-20.96
7	1215	10	ISO 1-4		-14.50	6.86	-22.71
8	1215	10	ISO 4-2		-14.50	6.51	-21.21
9	1215	10	ISO 4-3		-14.50	6.37	-22.20
10	1315	10	I.L. S-1	-07.80		7.25	-7.13
11	1315	10	I.L. S-2	-07.80		6.98	-7.21
12	1315	10	I.L. S-3	-07.80		6.86	-7.21
13	1315	10	I.L. S-4	-07.80		6.69	-7.16
14	1315	10	ISO 1-2		-14.50	7.05	-27.28
15	1315	10	ISO 1-3		-14.50	6.93	-25.21
16	1315	10	ISO 1-4		-14.50	6.75	-27.90
17	1315	10	ISO 4-2		-14.50	6.38	-25.19
18	1315	10	ISO 4-3		-14.50	6.25	-27.34
19	1900	10	I.L. S-1	-07.80		6.77	-6.97
20	1900	10	I.L. S-2	-07.80		6.44	-6.86
21	1900	10	I.L. S-3	-07.80		6.30	-6.84
22	1900	10	I.L. S-4	-07.80		6.06	-6.98
23	1900	10	ISO 1-2		-14.50	6.46	-19.86
24	1900	10	ISO 1-3		-14.50	6.35	-19.57
25	1900	10	ISO 1-4		-14.50	6.12	-19.18
26	1900	10	ISO 4-2		-14.50	5.75	-19.46
27	1900	10	ISO 4-3		-14.50	5.61	-19.77

Unit No: 2

Seq #	Freq (MHz)	Power (dBm)	Meas. Name	TSpec_Dn (dB)	TSpec_Up (dB)	Ref CAL. (dB)	Meas. Value (dB)
1	1215	10	I.L. S-1	-08.50		7.36	-7.84
2	1215	10	I.L. S-2	-08.50		7.08	-7.94
3	1215	10	I.L. S-3	-08.50		6.97	-7.86
4	1215	10	I.L. S-4	-08.50		6.81	-7.83

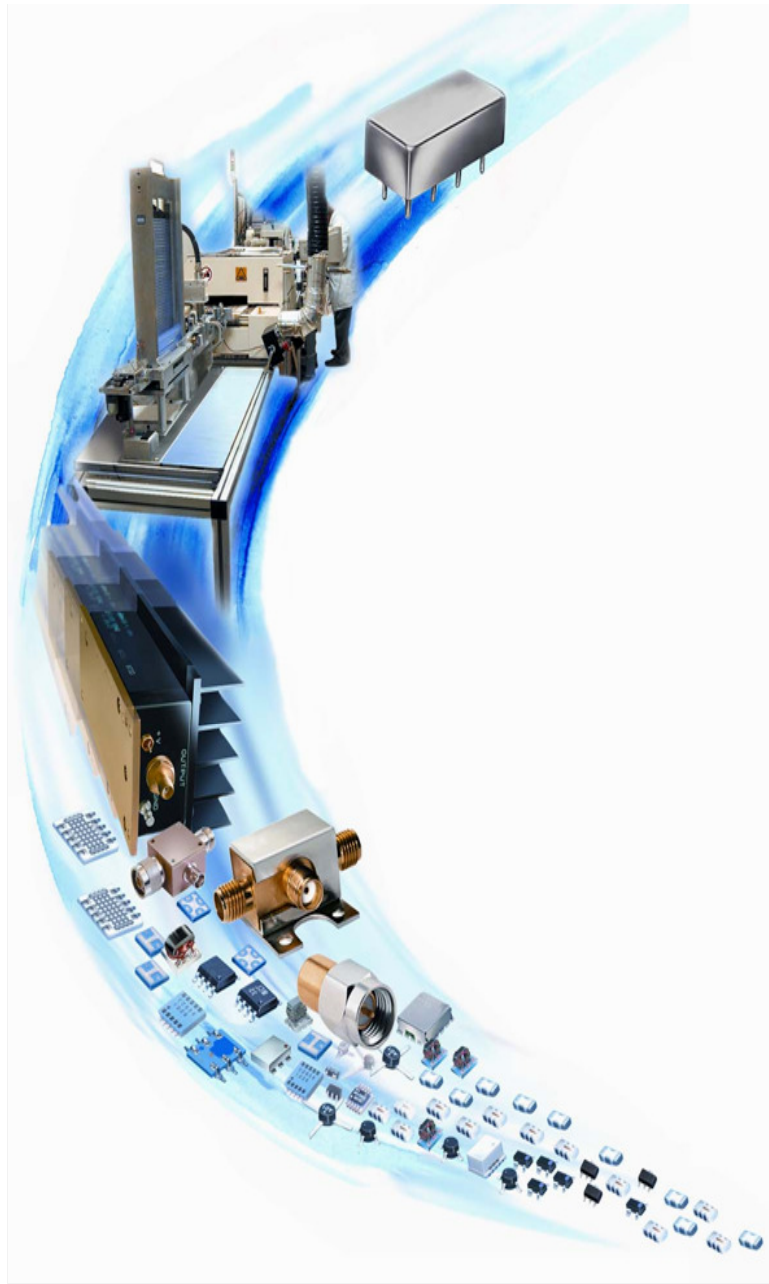

 **Mini-Circuits®**

Smart Portable Test Equipment

Thank you !